

Programming Guide

VLT® Flow Drive FC 111



Contents

1	Introduction	5
1.1	Purpose of this Programming Guide	5
1.2	Additional Resources	5
1.2.1	Other Resources	5
1.2.2	MCT 10 Set-up Software Support	5
1.3	Document and Software Version	5
1.4	Electrical Wiring	5
2	Safety	7
2.1	Safety Symbols	7
2.2	Qualified Personnel	7
2.3	Safety Precautions	7
3	Programming	9
3.1	Local Control Panel (LCP)	9
3.2	Menus	10
3.2.1	Status Menu	10
3.2.2	Quick Menu	10
3.2.2.1	Quick Menu Introduction	10
3.2.2.2	Setup Wizard Introduction	11
3.2.2.3	Setup Wizard for Open-loop Applications	12
3.2.2.4	Setup Wizard for Closed-loop Applications	17
3.2.2.5	Motor Setup	22
3.2.2.6	Changes Made Function	26
3.2.2.7	Changing Parameter Settings	26
3.2.2.8	Accessing All Parameters via the Main Menu	26
3.2.3	Main Menu	26
3.3	Quick Transfer of Parameter Settings between Multiple Drives	26
3.3.1	Transferring Data from the Drive to the LCP	26
3.3.2	Transferring Data from the LCP to the Drive	26
3.4	Readout and Programming of Indexed Parameters	26
3.5	Initialization to Default Settings	27
3.5.1	Recommended Initialization	27
3.5.2	Two-finger Initialization	27
4	Parameters	29
4.1	Parameter List	29
4.2	Parameter Group 0-** Operation / Display	32

4.3	Parameter Group 1-** Load and Motor	40
4.4	Parameter Group 2-** Brakes	57
4.5	Parameter Group 3-** Reference/Ramps	59
4.6	Parameter Group 4-** Limits/Warnings	64
4.7	Parameter Group 5-** Digital In/Out	68
4.8	Parameter Group 6-** Analog In/Out	91
4.9	Parameter Group 8-** Comm. and Options	103
4.10	Parameter Group 13-** Smart Logic	115
4.11	Parameter Group 14-** Special Functions	129
4.12	Parameter Group 15-** Drive Information	138
4.13	Parameter Group 16-** Data Readouts	144
4.14	Parameter Group 18-** Info & Readouts	156
4.15	Parameter Group 20-** Drive Closed Loop	157
4.16	Parameter Group 22-** Appl. Functions	164
4.17	Parameter Group 23-** Time-based Functions	177
4.18	Parameter Group 24-** Appl. Functions 2	178
4.19	Parameter Group 25-** Cascade Controller	183
4.20	Parameter Group 30-** Special Features	189
5	Troubleshooting	191
5.1	Warning and Alarm Messages	191
5.2	Alarm Words	193
5.3	Warning Words	194
5.4	Extended Status Words	195
5.5	Descriptions of Warnings and Alarms	196
5.6	LCP Errors Messages	203
6	Appendix	205
6.1	Abbreviations	205
6.2	Definitions	206
6.2.1	AC Drive	206
6.2.2	Input	206
6.2.3	Motor	206
6.2.4	References	207
6.2.5	Miscellaneous	208

1 Introduction

1.1 Purpose of this Programming Guide

This Programming Guide provides information on working with parameters on the VLT® Flow Drive FC 111 drive.

It provides information on how to programme the drive, and a list and description of all parameters.

VLT® is a registered trademark for Danfoss A/S.

1.2 Additional Resources

1.2.1 Other Resources

Other resources are available to understand advanced drive functions and programming.

- VLT® Flow Drive FC 111 Operating Guide provides basic information on mechanical dimensions, installation, and programming.
- VLT® Flow Drive FC 111 Design Guide provides information on how to design motor control systems.
- Danfoss VLT® Energy Box software. Select PC Software Download at www.danfoss.com.

VLT® Energy Box software allows energy consumption comparisons of HVAC fans and pumps driven by Danfoss drives and alternative methods of flow control. Use this tool to accurately project the costs, savings, and payback of using Danfoss drives on HVAC fans, pumps, and cooling towers.

Supplementary publications and manuals are available from Danfoss website.

1.2.2 MCT 10 Set-up Software Support

Download the software from the service and support section on www.danfoss.com.

During the installation process of the software, enter access code 81462700 to activate the VLT® Flow Drive FC 111 functionality. A license key is not required for using the VLT® Flow Drive FC 111 functionality.

The latest software does not always contain the latest updates for drives. Contact the local sales office for the latest drive updates (in the form of *.OSS files).

1.3 Document and Software Version

This guide is regularly reviewed and updated. All suggestions for improvement are welcome.

The original language of this manual is English.

Table 1: Document and Software Version

Edition	Remarks	Software version
AU363928304090, version 0101	First edition.	6x.xx

1.4 Electrical Wiring

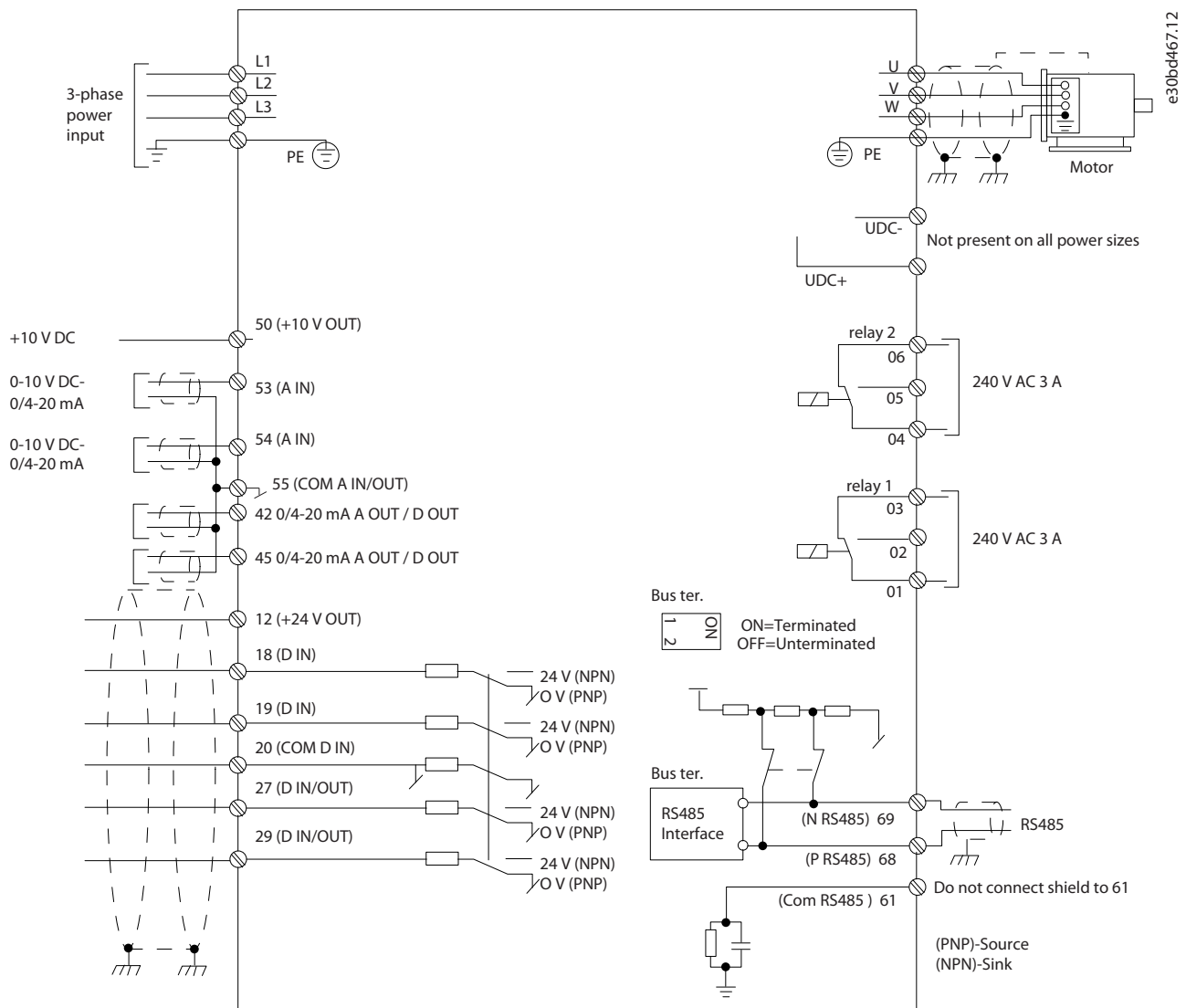

Illustration 1: Basic Wiring Schematic Drawing

NOTICE

There is no access to UDC- and UDC+ on the following units:

- IP20, 380-480 V, 30-315 kW (40-450 hp)

2 Safety

2.1 Safety Symbols

The following symbols are used in this manual:

⚠ D A N G E R ⚠

Indicates a hazardous situation which, if not avoided, will result in death or serious injury.

⚠ W A R N I N G ⚠

Indicates a hazardous situation which, if not avoided, could result in death or serious injury.

⚠ C A U T I O N ⚠

Indicates a hazardous situation which, if not avoided, could result in minor or moderate injury.

N O T I C E

Indicates information considered important, but not hazard-related (for example, messages relating to property damage).

2.2 Qualified Personnel

To allow trouble-free and safe operation of the unit, only qualified personnel with proven skills are allowed to transport, store, assemble, install, program, commission, maintain, and decommission this equipment.

Persons with proven skills:

- Are qualified electrical engineers, or persons who have received training from qualified electrical engineers and are suitably experienced to operate devices, systems, plant, and machinery in accordance with pertinent laws and regulations.
- Are familiar with the basic regulations concerning health and safety/accident prevention.
- Have read and understood the safety guidelines given in all manuals provided with the unit, especially the instructions given in the Operating Guide.
- Have good knowledge of the generic and specialist standards applicable to the specific application.

2.3 Safety Precautions

⚠ W A R N I N G ⚠

HAZARDOUS VOLTAGE

AC drives contain hazardous voltage when connected to the AC mains or connected on the DC terminals. Failure to perform installation, start-up, and maintenance by skilled personnel can result in death or serious injury.

- Only skilled personnel must perform installation, start-up, and maintenance.

⚠ W A R N I N G ⚠

UNINTENDED START

When the drive is connected to AC mains, DC supply, or load sharing, the motor may start at any time. Unintended start during programming, service, or repair work can result in death, serious injury, or property damage. Start the motor with an external switch, a fieldbus command, an input reference signal from the local control panel (LCP), via remote operation using MCT 10 software, or after a cleared fault condition.

- Disconnect the drive from the mains.
- Press [Off/Reset] on the LCP before programming parameters.
- Ensure that the drive is fully wired and assembled when it is connected to AC mains, DC supply, or load sharing.

⚠ W A R N I N G ⚠

DISCHARGE TIME

The drive contains DC-link capacitors, which can remain charged even when the drive is not powered. High voltage can be present even when the warning indicator lights are off.

Failure to wait the specified time after power has been removed before performing service or repair work could result in death or serious injury.

- Stop the motor.
- Disconnect AC mains, permanent magnet type motors, and remote DC-link supplies, including battery back-ups, UPS, and DC-link connections to other drives.
- Wait for the capacitors to discharge fully. The minimum waiting time is specified in the table *Discharge time* and is also visible on the nameplate on the top of the drive.
- Before performing any service or repair work, use an appropriate voltage measuring device to make sure that the capacitors are fully discharged.

Table 2: Discharge Time

Voltage [V]	Power range [kW (hp)]	Minimum waiting time (minutes)
3x400	0.37–7.5 (0.5–10)	4
3x400	11–90 (15–125)	15
3x400	110–315 (150–450)	20

⚠ W A R N I N G ⚠

LEAKAGE CURRENT HAZARD

Leakage currents exceed 3.5 mA. Failure to ground the drive properly can result in death or serious injury.

- Ensure that the minimum size of the ground conductor complies with the local safety regulations for high touch current equipment.

⚠ W A R N I N G ⚠

EQUIPMENT HAZARD

Contact with rotating shafts and electrical equipment can result in death or serious injury.

- Ensure that only trained and qualified personnel perform installation, start-up, and maintenance.
- Ensure that electrical work conforms to national and local electrical codes.
- Follow the procedures in this manual.

⚠ C A U T I O N ⚠

INTERNAL FAILURE HAZARD

An internal failure in the drive can result in serious injury when the drive is not properly closed.

- Ensure that all safety covers are in place and securely fastened before applying power.

3 Programming

3.1 Local Control Panel (LCP)

The LCP is divided into 4 functional sections.

- A. Display
- B. Menu key
- C. Navigation keys and indicator lights
- D. Operation keys and indicator lights

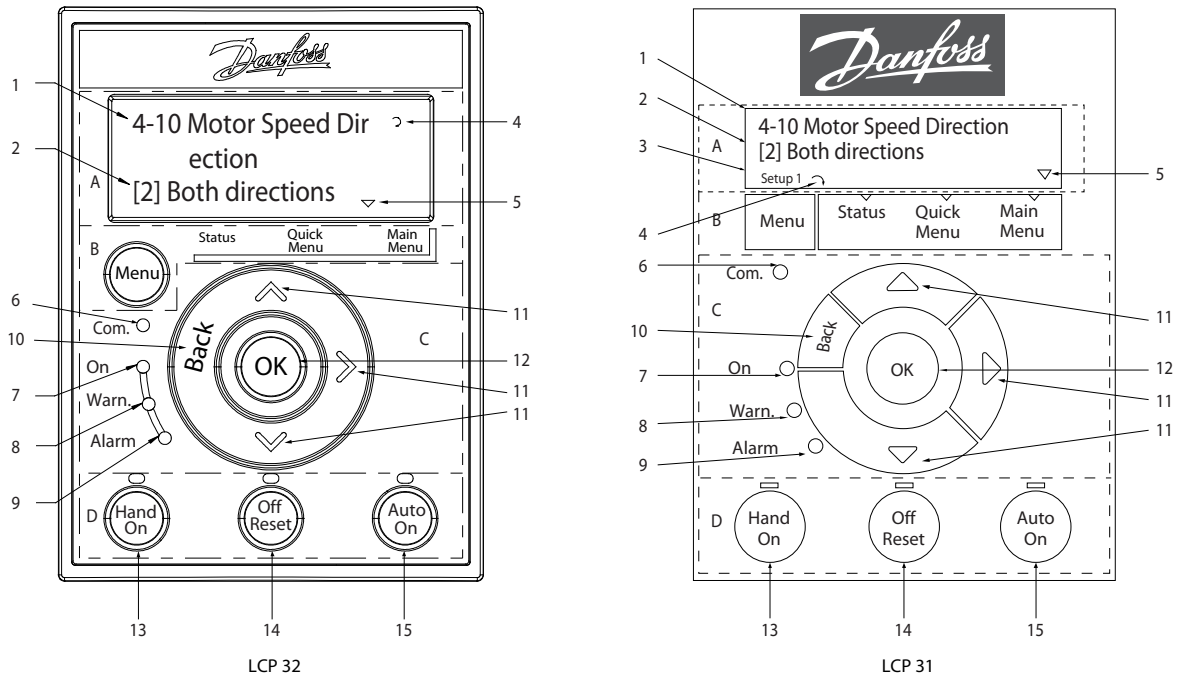

Illustration 2: Local Control Panel (LCP)

A. Display

The LCD-display of LCP 32 is illuminated with 3 alphanumeric lines, while the LCD-display of LCP 31 is illuminated with 2 alphanumeric lines. All data is shown on the LCP. The [Table 3](#) describes the information that can be read from the display.

Table 3: Legend to Section A, Illustration 3

1	Parameter number and name.
2	Parameter value.
3	The setup number shows the active setup and the edit setup. For LCP 32, the setup number only shows in Status menu, the number outside brackets is active setup, and the number inside brackets is edit setup. For example, 1(2) means 1 is the active setup, and 2 is the edit setup. For LCP 31, if the same setup acts as both active and edit setup, only that setup number is shown (factory setting). When the active and the edit setup differ, both numbers are shown in the display (setup 12). The number flashing indicates the edit setup.
4	Motor direction is shown to the bottom left of the display – indicated by a small arrow pointing either clockwise or counter-clockwise.
5	The triangle indicates if the LCP is in Status, Quick Menu, or Main Menu.

B. Menu key

Press [Menu] to select among Status, Quick Menu, or Main Menu.

C. Navigation keys and indicator lights

Table 4: Legend to Section C, Illustration 3

6	Com. (yellow indicator): Flashes during bus communication.
7	On (green indicator): Shows the power-on status.
8	Warn. (yellow indicator): Indicates a warning.
9	Alarm (red indicator): Indicates an alarm.
10	[Back]: For moving to the previous step or layer in the navigation structure.
11	Up arrow key, down arrow key, and right arrow key: For navigating among parameter groups and parameters, and within parameters. They can also be used for setting local reference.
12	[OK]: For selecting a parameter and for accepting changes to parameter settings.

D. Operation keys and indicator lights

Table 5: Legend to Section D, Illustration 3

13	[Hand On]: Starts the motor and enables control of the drive via the LCP.
<div style="background-color: #cccccc; padding: 5px; margin: 5px 0;">NOTICE</div> <p>[2] <i>Coast inverse</i> is the default option for <i>parameter 5-12 Terminal 27 Digital Input</i>. If there is no 24 V supply to terminal 27, [Hand On] does not start the motor. Connect terminal 12 to terminal 27.</p>	
14	[Off/Reset]: Stops the compressor (Off). If in alarm mode, the alarm is reset.
15	[Auto On]: The drive is controlled either via control terminals or serial communication.

3.2 Menus

3.2.1 Status Menu

In the Status menu, the selection options are:

- Motor frequency [Hz], *parameter 16-13 Frequency*.
- Motor current [A], *parameter 16-14 Motor current*.
- Motor speed reference in percentage [%], *parameter 16-02 Reference [%]*.
- Feedback, *parameter 16-52 Feedback [Unit]*.
- Motor power *parameter 16-10 Power [kW]* for kW, *parameter 16-11 Power [hp]* for hp. If *parameter 0-03 Regional Settings* is set to [1] *North America*, motor power is shown in hp instead of kW.
- Custom readout, *parameter 16-09 Custom Readout*.
- Motor Speed [RPM], *parameter 16-17 Speed [RPM]*.

3.2.2 Quick Menu

3.2.2.1 Quick Menu Introduction

Use the Quick Menu to program the most common functions. The Quick Menu consists of:

- Wizard for open-loop applications.
- Wizard for closed-loop applications.
- Motor set-up.
- Changes made.

3.2.2.2 Setup Wizard Introduction

The built-in wizard menu guides the installer through the setup of the drive in a clear and structured manner for open-loop and closed-loop applications, and for quick motor settings.

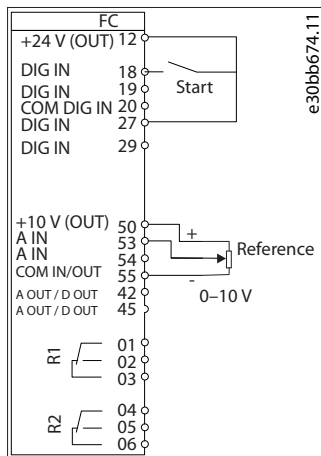
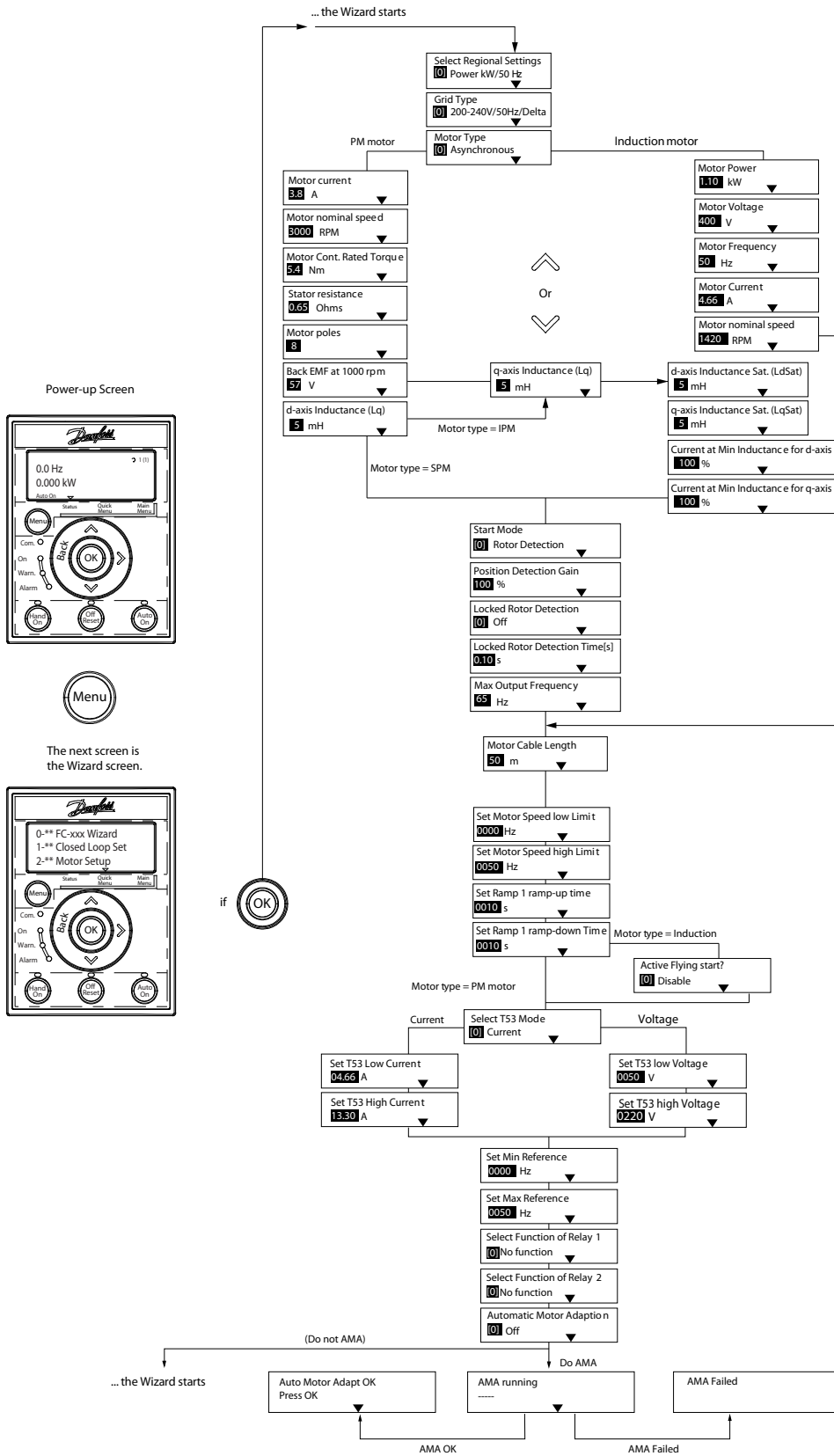

Illustration 3: Drive Wiring

The wizard can always be accessed again through the quick menu. Press [OK] to start the wizard. Press [Back] to return to the status view.

3.2.2.3 Setup Wizard for Open-loop Applications



e30bu808.12

Illustration 4: Setup Wizard for Open-loop Applications

Table 6: Setup Wizard for Open-loop Applications

Parameter	Option	Default	Usage
<i>Parameter 0-03 Regional Settings</i>	[0] International [1] US	[0] International	–
<i>Parameter 0-06 GridType</i>	[10] 380–440 V/50 Hz/IT-grid [11] 380–440 V/50 Hz/Delta [12] 380–440 V/50 Hz [20] 440–480 V/50 Hz/IT-grid [21] 440–480 V/50 Hz/Delta [22] 440–480 V/50 Hz [110] 380–440 V/60 Hz/IT-grid [111] 380–440 V/60 Hz/Delta [112] 380–440 V/60 Hz [120] 440–480 V/60 Hz/IT-grid [121] 440–480 V/60 Hz/Delta [122] 440–480 V/60 Hz	Size related	Select the operating mode for restart after reconnection of the drive to mains voltage after power down. <div style="text-align: center; background-color: #cccccc; padding: 5px;">NOTICE</div> <p>Compared to 380–440 V groups, when selecting 440–480 V groups, the rated current decreases accordingly.</p>
<i>Parameter 1-10 Motor Construction</i>	*[0] Asynchron [1] PM, non-salient SPM [3] PM, salient IPM	[0] Asynchron	Setting the parameter value might change these parameters: <ul style="list-style-type: none"> • <i>Parameter 1-01 Motor Control Principle.</i> • <i>Parameter 1-03 Torque Characteristics.</i> • <i>Parameter 1-08 Motor Control Bandwidth.</i> • <i>Parameter 1-14 Damping Gain.</i> • <i>Parameter 1-15 Low Speed Filter Time Const.</i> • <i>Parameter 1-16 High Speed Filter Time Const.</i> • <i>Parameter 1-17 Voltage Filter Time Const.</i> • <i>Parameter 1-20 Motor Power.</i> • <i>Parameter 1-22 Motor Voltage.</i> • <i>Parameter 1-23 Motor Frequency.</i> • <i>Parameter 1-24 Motor Current.</i> • <i>Parameter 1-25 Motor Nominal Speed.</i> • <i>Parameter 1-26 Motor Cont. Rated Torque.</i> • <i>Parameter 1-30 Stator Resistance (Rs).</i> • <i>Parameter 1-33 Stator Leakage Reactance (X1).</i> • <i>Parameter 1-35 Main Reactance (Xh).</i> • <i>Parameter 1-37 d-axis Inductance (Ld).</i> • <i>Parameter 1-38 q-axis Inductance (Lq).</i> • <i>Parameter 1-39 Motor Poles.</i> • <i>Parameter 1-40 Back EMF at 1000 RPM.</i> • <i>Parameter 1-44 d-axis Inductance Sat. (LdSat).</i> • <i>Parameter 1-45 q-axis Inductance Sat. (LqSat).</i> • <i>Parameter 1-46 Position Detection Gain.</i> • <i>Parameter 1-48 Current at Min Inductance for d-axis.</i> • <i>Parameter 1-49 Current at Min Inductance for q-axis.</i> • <i>Parameter 1-66 Min. Current at Low Speed.</i>

Parameter	Option	Default	Usage
			<ul style="list-style-type: none"> Parameter 1-70 PM Start Mode. Parameter 1-72 Start Function. Parameter 1-73 Flying Start. Parameter 1-80 Function at Stop. Parameter 1-82 Min Speed for Function at Stop [Hz]. Parameter 1-90 Motor Thermal Protection. Parameter 2-00 DC Hold/Motor Preheat Current. Parameter 2-01 DC Brake Current. Parameter 2-02 DC Braking Time. Parameter 2-04 DC Brake Cut In Speed. Parameter 2-10 Brake Function. Parameter 4-14 Motor Speed High Limit [Hz]. Parameter 4-19 Max Output Frequency. Parameter 4-58 Missing Motor Phase Function. Parameter 14-65 Speed Derate Dead Time Compensation.
Parameter 1-20 Motor Power	0.18–110 kW/0.25–150 hp	Size related	Enter the motor power from the nameplate data.
Parameter 1-22 Motor Voltage	50–1000 V	Size related	Enter the motor voltage from the nameplate data.
Parameter 1-23 Motor Frequency	20–400 Hz	Size related	Enter the motor frequency from the nameplate data.
Parameter 1-24 Motor Current	0.01–1000.00 A	Size related	Enter the motor current from the nameplate data.
Parameter 1-25 Motor Nominal Speed	50–9999 RPM	Size related	Enter the motor nominal speed from the nameplate data.
Parameter 1-26 Motor Cont. Rated Torque	0.1–1000.0 Nm	Size related	<p>This parameter is available when <i>parameter 1-10 Motor Construction</i> is set to options that enable permanent motor mode.</p> <div style="border: 1px solid black; padding: 5px; margin-top: 10px;"> <p style="text-align: center; margin: 0;">NOTICE</p> <p>Changing this parameter affects the settings of other parameters.</p> </div>
Parameter 1-29 Automatic Motor Adaption (AMA)	See <i>parameter 1-29 Automatic Motor Adaption (AMA)</i> .	Off	Performing an AMA optimizes motor performance.
Parameter 1-30 Stator Resistance (Rs)	0.000–99.990 Ω	Size related	Set the stator resistance value.
Parameter 1-37 d-axis Inductance (Ld)	0.000–1000.000 mH	Size related	Enter the value of the d-axis inductance. Obtain the value from the permanent magnet motor datasheet.

Parameter	Option	Default	Usage
<i>Parameter 1-38 q-axis Induc- tance (Lq)</i>	0.000–1000.000 mH	Size related	Enter the value of the q-axis inductance.
<i>Parameter 1-39 Motor Poles</i>	2–100	4	Enter the number of motor poles.
<i>Parameter 1-40 Back EMF at 1000 RPM</i>	10–9000 V	Size related	Line-line RMS back EMF voltage at 1000 RPM.
<i>Parameter 1-42 Motor Cable Length</i>	0–100 m	50 m	Enter the motor cable length.
<i>Parameter 1-44 d-axis Induc- tance Sat. (LdSat)</i>	0.000–1000.000 mH	Size related	This parameter corresponds to the inductance saturation of Ld. Ideally, this parameter has the same value as <i>parameter 1-37 d-axis Inductance (Ld)</i> . However, if the motor supplier provides an induction curve, enter the induction value, which is 200% of the nominal current.
<i>Parameter 1-45 q-axis Induc- tance Sat. (LqSat)</i>	0.000–1000.000 mH	Size related	This parameter corresponds to the inductance saturation of Lq. Ideally, this parameter has the same value as <i>parameter 1-38 q-axis Inductance (Lq)</i> . However, if the motor supplier provides an induction curve, enter the induction value, which is 200% of the nominal current.
<i>Parameter 1-46 Position Detec- tion Gain</i>	20–200%	100%	Adjusts the height of the test pulse during position detec- tion at start.
<i>Parameter 1-48 Current at Min Inductance for d-axis</i>	20–200%	100%	Enter the inductance saturation point.
<i>Parameter 1-49 Current at Min Inductance for q-axis</i>	20–200%	100%	This parameter specifies the saturation curve of the d- and q- inductance values. From 20–100% of this parameter, the in- ductances are linearly approximated due to <i>parameter 1-37 d-axis Inductance (Ld)</i> , <i>parameter 1-38 q-axis Inductance (Lq)</i> , <i>parameter 1-44 d-axis Inductance Sat. (LdSat)</i> , and <i>parameter 1-45 q-axis Inductance Sat. (LqSat)</i> .
<i>Parameter 1-70 PM Start Mode</i>	[0] Rotor Detection [1] Parking [3] Rotor Last Position	[1] Parking	Select the PM motor start mode.
<i>Parameter 1-73 Flying Start</i>	[0] Disabled [1] Enabled	[0] Disabled	Select [1] Enabled to enable the drive to catch a motor spin- ning due to mains drop-out. Select [0] Disabled if this func- tion is not required. When this parameter is set to [1] Ena- bled, <i>parameter 1-71 Start Delay</i> and <i>parameter 1-72 Start Function</i> are not functional. <i>Parameter 1-73 Flying Start</i> is ac- tive in VVC ⁺ mode only.
<i>Parameter 3-02 Minimum Refer- ence</i>	-4999.000–4999.000	0	The minimum reference is the lowest value obtainable by summing all references.
<i>Parameter 3-03 Maximum Ref- erence</i>	-4999.000–4999.000	50	The maximum reference is the lowest obtainable by sum- ming all references.

Parameter	Option	Default	Usage
<i>Parameter 3-41 Ramp 1 Ramp Up Time</i>	0.01–3600.00 s	Size related	If induction motor is selected, the ramp-up time is from 0 to rated <i>parameter 1-23 Motor Frequency</i> . If PM motor is selected, the ramp-up time is from 0 to <i>parameter 1-25 Motor Nominal Speed</i> .
<i>Parameter 3-42 Ramp 1 Ramp Down Time</i>	0.01–3600.00 s	Size related	For induction motors, the ramp-down time is from rated <i>parameter 1-23 Motor Frequency</i> to 0. For PM motors, the ramp-down time is from <i>parameter 1-25 Motor Nominal Speed</i> to 0.
<i>Parameter 4-12 Motor Speed Low Limit [Hz]</i>	0.0–400.0 Hz	0 Hz	Enter the minimum limit for low speed.
<i>Parameter 4-14 Motor Speed High Limit [Hz]</i>	0.0–400.0 Hz	100 Hz	Enter the maximum limit for high speed.
<i>Parameter 4-19 Max Output Frequency</i>	0.0–400.0 Hz	100 Hz	Enter the maximum output frequency value. If <i>parameter 4-19 Max Output Frequency</i> is set lower than <i>parameter 4-14 Motor Speed High Limit [Hz]</i> , <i>parameter 4-14 Motor Speed High Limit [Hz]</i> is set equal to <i>parameter 4-19 Max Output Frequency</i> automatically.
<i>Parameter 5-40 Function Relay</i>	See <i>parameter 5-40 Function Relay</i> .	[9] Alarm	Select the function to control output relay 1.
<i>Parameter 5-40 Function Relay</i>	See <i>parameter 5-40 Function Relay</i> .	[5] Drive running	Select the function to control output relay 2.
<i>Parameter 6-10 Terminal 53 Low Voltage</i>	0.00–10.00 V	0.07 V	Enter the voltage that corresponds to the low reference value.
<i>Parameter 6-11 Terminal 53 High Voltage</i>	0.00–10.00 V	10 V	Enter the voltage that corresponds to the high reference value.
<i>Parameter 6-12 Terminal 53 Low Current</i>	0.00–20.00 mA	4 mA	Enter the current that corresponds to the low reference value.
<i>Parameter 6-13 Terminal 53 High Current</i>	0.00–20.00 mA	20 mA	Enter the current that corresponds to the high reference value.
<i>Parameter 6-19 Terminal 53 mode</i>	[0] Current [1] Voltage	[1] Voltage	Select if terminal 53 is used for current or voltage input.
<i>Parameter 30-22 Locked Rotor Detection</i>	[0] Off [1] On	[0] Off	–
<i>Parameter 30-23 Locked Rotor Detection Time [s]</i>	0.05–1 s	0.10 s	–

3.2.2.4 Setup Wizard for Closed-loop Applications

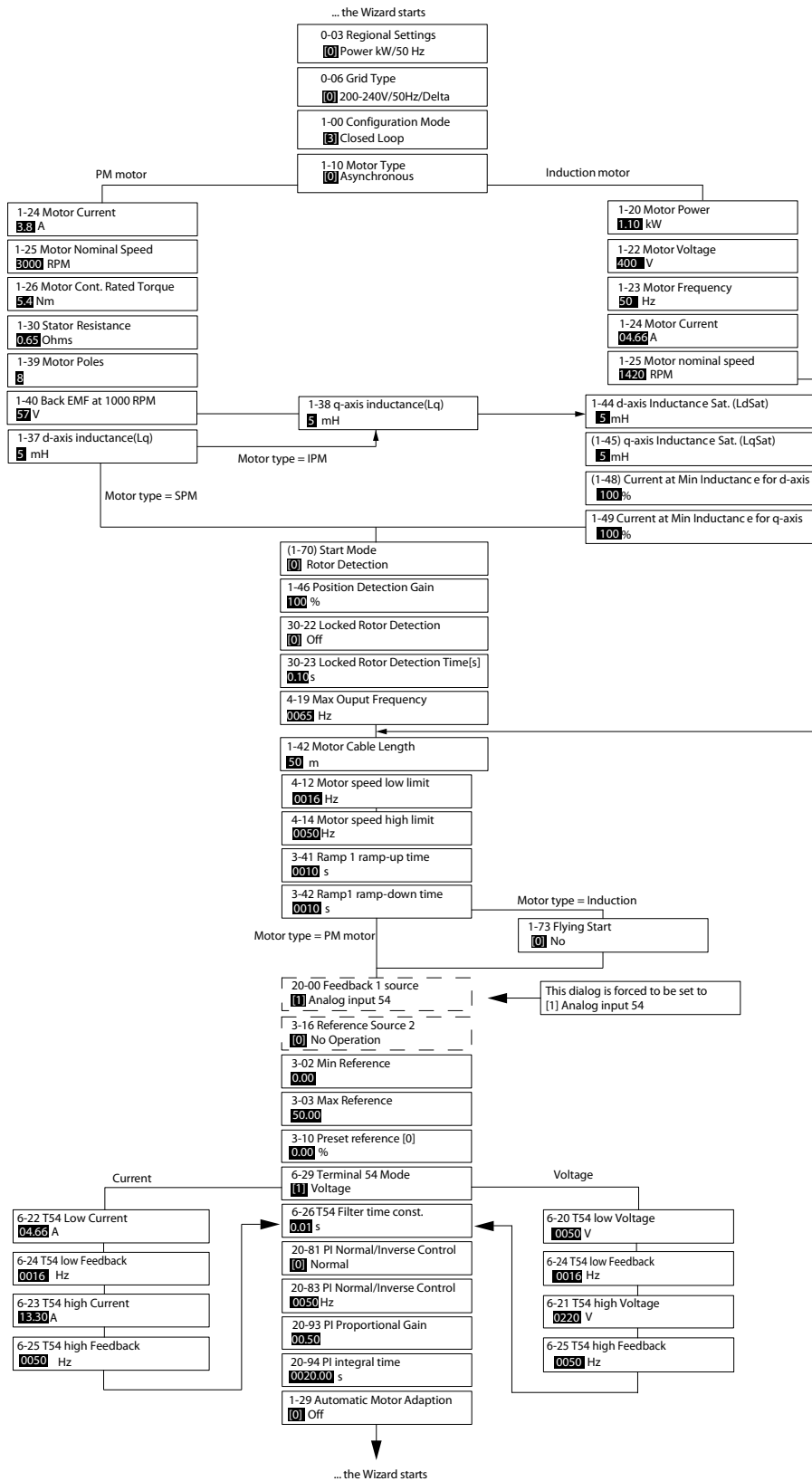

e30bc402.16

Illustration 5: Setup Wizard for Closed-loop Applications

Table 7: Setup Wizard for Closed-loop Applications

Parameter	Range	Default	Usage
<i>Parameter 0-03 Regional Set- tings</i>	[0] International [1] US	<i>[0] Interna- tional</i>	–
<i>Parameter 0-06 GridType</i>	[10] 380–440 V/50 Hz/IT-grid [11] 380–440 V/50 Hz/Delta [12] 380–440 V/50 Hz [20] 440–480 V/50 Hz/IT-grid [21] 440–480 V/50 Hz/Delta [22] 440–480 V/50 Hz [110] 380–440 V/60 Hz/IT-grid [111] 380–440 V/60 Hz/Delta [112] 380–440 V/60 Hz [120] 440–480 V/60 Hz/IT-grid [121] 440–480 V/60 Hz/Delta [122] 440–480 V/60 Hz	Size selected	Select the operating mode for restart after reconnection of the drive to mains voltage after power down.
<i>Parameter 1-00 Configuration Mode</i>	[0] Open loop [3] Closed loop	<i>[0] Open loop</i>	Select <i>[3] Closed loop</i> .
<i>Parameter 1-10 Motor Con- struction</i>	*[0] Asynchron [1] PM, non-salient SPM [3] PM, salient IPM	<i>[0] Asynchron</i>	Setting the parameter value might change these parameters: <ul style="list-style-type: none"> • <i>Parameter 1-01 Motor Control Principle.</i> • <i>Parameter 1-03 Torque Characteristics.</i> • <i>Parameter 1-08 Motor Control Bandwidth.</i> • <i>Parameter 1-14 Damping Gain.</i> • <i>Parameter 1-15 Low Speed Filter Time Const.</i> • <i>Parameter 1-16 High Speed Filter Time Const.</i> • <i>Parameter 1-17 Voltage Filter Time Const.</i> • <i>Parameter 1-20 Motor Power.</i> • <i>Parameter 1-22 Motor Voltage.</i> • <i>Parameter 1-23 Motor Frequency.</i> • <i>Parameter 1-24 Motor Current.</i> • <i>Parameter 1-25 Motor Nominal Speed.</i> • <i>Parameter 1-26 Motor Cont. Rated Torque.</i> • <i>Parameter 1-30 Stator Resistance (Rs).</i> • <i>Parameter 1-33 Stator Leakage Reactance (X1).</i> • <i>Parameter 1-35 Main Reactance (Xh).</i> • <i>Parameter 1-37 d-axis Inductance (Ld).</i> • <i>Parameter 1-38 q-axis Inductance (Lq).</i> • <i>Parameter 1-39 Motor Poles.</i> • <i>Parameter 1-40 Back EMF at 1000 RPM.</i> • <i>Parameter 1-44 d-axis Inductance Sat. (LdSat).</i> • <i>Parameter 1-45 q-axis Inductance Sat. (LqSat).</i> • <i>Parameter 1-46 Position Detection Gain.</i> • <i>Parameter 1-48 Current at Min Inductance for d-axis.</i>

Parameter	Range	Default	Usage
			<ul style="list-style-type: none"> Parameter 1-49 Current at Min Inductance for q-axis. Parameter 1-66 Min. Current at Low Speed. Parameter 1-70 PM Start Mode. Parameter 1-72 Start Function. Parameter 1-73 Flying Start. Parameter 1-80 Function at Stop. Parameter 1-82 Min Speed for Function at Stop [Hz]. Parameter 1-90 Motor Thermal Protection. Parameter 2-00 DC Hold/Motor Preheat Current. Parameter 2-01 DC Brake Current. Parameter 2-02 DC Braking Time. Parameter 2-04 DC Brake Cut In Speed. Parameter 2-10 Brake Function. Parameter 4-14 Motor Speed High Limit [Hz]. Parameter 4-19 Max Output Frequency. Parameter 4-58 Missing Motor Phase Function. Parameter 14-65 Speed Derate Dead Time Compensation.
Parameter 1-20 Motor Power	0.18–110 kW/0.25–150 hp	Size related	Enter the motor power from the nameplate data.
Parameter 1-22 Motor Voltage	50–1000 V	Size related	Enter the motor voltage from the nameplate data.
Parameter 1-23 Motor Frequency	20–400 Hz	Size related	Enter the motor frequency from the nameplate data.
Parameter 1-24 Motor Current	0.01–1000.00 A	Size related	Enter the motor current from the nameplate data.
Parameter 1-25 Motor Nominal Speed	50–60000 RPM	Size related	Enter the motor nominal speed from the nameplate data.
Parameter 1-26 Motor Cont. Rated Torque	0.1–10000.0 Nm	Size related	<p>This parameter is available when <i>parameter 1-10 Motor Construction</i> is set to options that enable permanent motor mode.</p> <div style="border: 1px solid black; padding: 5px; text-align: center;"> <p>NOTICE</p> <p>Changing this parameter affects the settings of other parameters.</p> </div>
Parameter 1-29 Automatic Motor Adaption (AMA)	–	Off	Performing an AMA optimizes motor performance.
Parameter 1-30 Stator Resistance (Rs)	0.000–9999.000 Ω	Size related	Set the stator resistance value.

Parameter	Range	Default	Usage
<i>Parameter 1-37 d-axis Inductance (Ld)</i>	0.000–1000.000 mH	Size related	Enter the value of the d-axis inductance. Obtain the value from the permanent magnet motor datasheet.
<i>Parameter 1-38 q-axis Inductance (Lq)</i>	0.000–1000.000 mH	Size related	Enter the value of the q-axis inductance.
<i>Parameter 1-39 Motor Poles</i>	2–100	4	Enter the number of motor poles.
<i>Parameter 1-40 Back EMF at 1000 RPM</i>	10–9000 V	Size related	Line-line RMS back EMF voltage at 1000 RPM.
<i>Parameter 1-42 Motor Cable Length</i>	0–100 m	50 m	Enter the motor cable length.
<i>Parameter 1-44 d-axis Inductance Sat. (LdSat)</i>	0.000–1000.000 mH	Size related	This parameter corresponds to the inductance saturation of Ld. Ideally, this parameter has the same value as <i>parameter 1-37 d-axis Inductance (Ld)</i> . However, if the motor supplier provides an induction curve, enter the induction value, which is 200% of the nominal current.
<i>Parameter 1-45 q-axis Inductance Sat. (LqSat)</i>	0.000–1000.000 mH	Size related	This parameter corresponds to the inductance saturation of Lq. Ideally, this parameter has the same value as <i>parameter 1-38 q-axis Inductance (Lq)</i> . However, if the motor supplier provides an induction curve, enter the induction value, which is 200% of the nominal current.
<i>Parameter 1-46 Position Detection Gain</i>	20–200%	100%	Adjusts the height of the test pulse during position detection at start.
<i>Parameter 1-48 Current at Min Inductance for d-axis</i>	20–200%	100%	Enter the inductance saturation point.
<i>Parameter 1-49 Current at Min Inductance for q-axis</i>	20–200%	100%	This parameter specifies the saturation curve of the d- and q-inductance values. From 20–100% of this parameter, the inductances are linearly approximated due to <i>parameter 1-37 d-axis Inductance (Ld)</i> , <i>parameter 1-38 q-axis Inductance (Lq)</i> , <i>parameter 1-44 d-axis Inductance Sat. (LdSat)</i> , and <i>parameter 1-45 q-axis Inductance Sat. (LqSat)</i> .
<i>Parameter 1-70 PM Start Mode</i>	[0] Rotor Detection [1] Parking [3] Rotor Last Position	[1] Parking	Select the PM motor start mode.
<i>Parameter 1-73 Flying Start</i>	[0] Disabled [1] Enabled	[0] Disabled	Select [1] Enabled to enable the drive to catch a spinning motor in, for example, fan applications. When PM is selected, this parameter is enabled.
<i>Parameter 3-02 Minimum Reference</i>	-4999.000–4999.000	0	The minimum reference is the lowest value obtainable by summing all references.

Parameter	Range	Default	Usage
<i>Parameter 3-03 Maximum Reference</i>	-4999.000–4999.000	50	The maximum reference is the highest value obtainable by summing all references.
<i>Parameter 3-10 Preset Reference</i>	-100–100%	0	Enter the setpoint.
<i>Parameter 3-41 Ramp 1 Ramp Up Time</i>	0.05–3600.0 s	Size related	Ramp-up time from 0 to rated <i>parameter 1-23 Motor Frequency</i> for induction motors. Ramp-up time from 0 to <i>parameter 1-25 Motor Nominal Speed</i> for PM motors.
<i>Parameter 3-42 Ramp 1 Ramp Down Time</i>	0.05–3600.0 s	Size related	Ramp-down time from rated <i>parameter 1-23 Motor Frequency</i> to 0 for induction motors. Ramp-down time from <i>parameter 1-25 Motor Nominal Speed</i> to 0 for PM motors.
<i>Parameter 4-12 Motor Speed Low Limit [Hz]</i>	0.0–400.0 Hz	0.0 Hz	Enter the minimum limit for low speed.
<i>Parameter 4-14 Motor Speed High Limit [Hz]</i>	0.0–400.0 Hz	100 Hz	Enter the minimum limit for high speed.
<i>Parameter 4-19 Max Output Frequency</i>	0.0–400.0 Hz	100 Hz	Enter the maximum output frequency value. If <i>parameter 4-19 Max Output Frequency</i> is set lower than <i>parameter 4-14 Motor Speed High Limit [Hz]</i> , <i>parameter 4-14 Motor Speed High Limit [Hz]</i> is set equal to <i>parameter 4-19 Max Output Frequency</i> automatically.
<i>Parameter 6-20 Terminal 54 Low Voltage</i>	0.00–10.00 V	0.07 V	Enter the voltage that corresponds to the low reference value.
<i>Parameter 6-21 Terminal 54 High Voltage</i>	0.00–10.00 V	10.00 V	Enter the voltage that corresponds to the high reference value.
<i>Parameter 6-22 Terminal 54 Low Current</i>	0.00–20.00 mA	4.00 mA	Enter the current that corresponds to the low reference value.
<i>Parameter 6-23 Terminal 54 High Current</i>	0.00–20.00 mA	20.00 mA	Enter the current that corresponds to the high reference value.
<i>Parameter 6-24 Terminal 54 Low Ref./Feedb. Value</i>	-4999–4999	0	Enter the feedback value that corresponds to the voltage or current set in <i>parameter 6-20 Terminal 54 Low Voltage/parameter 6-22 Terminal 54 Low Current</i> .
<i>Parameter 6-25 Terminal 54 High Ref./Feedb. Value</i>	-4999–4999	50	Enter the feedback value that corresponds to the voltage or current set in <i>parameter 6-21 Terminal 54 High Voltage/parameter 6-23 Terminal 54 High Current</i> .
<i>Parameter 6-26 Terminal 54 Filter Time Constant</i>	0.00–10.00 s	0.01	Enter the filter time constant.

Parameter	Range	Default	Usage
Parameter 6-29 Terminal 54 mode	[0] Current [1] Voltage	[1] Voltage	Select if terminal 54 is used for current or voltage input.
Parameter 20-81 PI Normal/Inverse Control	[0] Normal [1] Inverse	[0] Normal	Select [0] Normal to set the process control to increase the output speed when the process error is positive. Select [1] Inverse to reduce the output speed.
Parameter 20-83 PI Start Speed [Hz]	0–200 Hz	0 Hz	Enter the motor speed to be attained as a start signal for commencement of PI control.
Parameter 20-93 PI Proportional Gain	0.00–10.00	0.01	Enter the process controller proportional gain. Quick control is obtained at high amplification. However, if amplification is too high, the process may become unstable.
Parameter 20-94 PI Integral Time	0.1–999.0 s	999.0 s	Enter the process controller integral time. Obtain quick control through a short integral time, though if the integral time is too short, the process becomes unstable. An excessively long integral time disables the integral action.
Parameter 30-22 Locked Rotor Detection	[0] Off [1] On	[0] Off	–
Parameter 30-23 Locked Rotor Detection Time [s]	0.05–1.00 s	0.10 s	–

3.2.2.5 Motor Setup

The motor setup wizard guides users through the needed motor parameters.

Table 8: Motor Setup Wizard Settings

Parameter	Range	Default	Usage
Parameter 0-03 Regional Settings	[0] International [1] US	[0] International	–
Parameter 0-06 GridType	[10] 380–440 V/50 Hz/IT-grid [11] 380–440 V/50 Hz/Delta [12] 380–440 V/50 Hz [20] 440–480 V/50 Hz/IT-grid [21] 440–480 V/50 Hz/Delta [22] 440–480 V/50 Hz [110] 380–440 V/60 Hz/IT-grid [111] 380–440 V/60 Hz/Delta [112] 380–440 V/60 Hz [120] 440–480 V/60 Hz/IT-grid [121] 440–480 V/60 Hz/Delta [122] 440–480 V/60 Hz	Size selected	Select the operating mode for restart after reconnection of the drive to mains voltage after power down.
Parameter 1-10 Motor Construction	*[0] Asynchron [1] PM, non-salient SPM [3] PM, salient IPM	[0] Asynchron	Setting the parameter value might change these parameters:

Parameter	Range	Default	Usage
			<ul style="list-style-type: none"> • <i>Parameter 1-01 Motor Control Principle.</i> • <i>Parameter 1-03 Torque Characteristics.</i> • <i>Parameter 1-08 Motor Control Bandwidth.</i> • <i>Parameter 1-14 Damping Gain.</i> • <i>Parameter 1-15 Low Speed Filter Time Const.</i> • <i>Parameter 1-16 High Speed Filter Time Const.</i> • <i>Parameter 1-17 Voltage Filter Time Const.</i> • <i>Parameter 1-20 Motor Power.</i> • <i>Parameter 1-22 Motor Voltage.</i> • <i>Parameter 1-23 Motor Frequency.</i> • <i>Parameter 1-24 Motor Current.</i> • <i>Parameter 1-25 Motor Nominal Speed.</i> • <i>Parameter 1-26 Motor Cont. Rated Torque.</i> • <i>Parameter 1-30 Stator Resistance (Rs).</i> • <i>Parameter 1-33 Stator Leakage Reactance (X1).</i> • <i>Parameter 1-35 Main Reactance (Xh).</i> • <i>Parameter 1-37 d-axis Inductance (Ld).</i> • <i>Parameter 1-38 q-axis Inductance (Lq).</i> • <i>Parameter 1-39 Motor Poles.</i> • <i>Parameter 1-40 Back EMF at 1000 RPM.</i> • <i>Parameter 1-44 d-axis Inductance Sat. (LdSat).</i> • <i>Parameter 1-45 q-axis Inductance Sat. (LqSat).</i> • <i>Parameter 1-46 Position Detection Gain.</i> • <i>Parameter 1-48 Current at Min Inductance for d-axis.</i> • <i>Parameter 1-49 Current at Min Inductance for q-axis.</i> • <i>Parameter 1-66 Min. Current at Low Speed.</i> • <i>Parameter 1-70 PM Start Mode.</i> • <i>Parameter 1-72 Start Function.</i> • <i>Parameter 1-73 Flying Start.</i> • <i>Parameter 1-80 Function at Stop.</i> • <i>Parameter 1-82 Min Speed for Function at Stop [Hz].</i> • <i>Parameter 1-90 Motor Thermal Protection.</i> • <i>Parameter 2-00 DC Hold/Motor Preheat Current.</i> • <i>Parameter 2-01 DC Brake Current.</i> • <i>Parameter 2-02 DC Braking Time.</i> • <i>Parameter 2-04 DC Brake Cut In Speed.</i> • <i>Parameter 2-10 Brake Function.</i> • <i>Parameter 4-14 Motor Speed High Limit [Hz].</i> • <i>Parameter 4-19 Max Output Frequency.</i> • <i>Parameter 4-58 Missing Motor Phase Function.</i> • <i>Parameter 14-65 Speed Derate Dead Time Compensation.</i>

Parameter	Range	Default	Usage
<i>Parameter 1-20 Motor Power</i>	0.18–110 kW/0.25–150 hp	Size related	Enter the motor power from the nameplate data.
<i>Parameter 1-22 Motor Voltage</i>	50–1000 V	Size related	Enter the motor voltage from the nameplate data.
<i>Parameter 1-23 Motor Frequency</i>	20–400 Hz	Size related	Enter the motor frequency from the nameplate data.
<i>Parameter 1-24 Motor Current</i>	0.01–10000.00 A	Size related	Enter the motor current from the nameplate data.
<i>Parameter 1-25 Motor Nominal Speed</i>	50–9999 RPM	Size related	Enter the motor nominal speed from the nameplate data.
<i>Parameter 1-26 Motor Cont. Rated Torque</i>	0.1–1000.0 Nm	Size related	This parameter is available when <i>parameter 1-10 Motor Construction</i> is set to options that enable permanent motor mode. <div style="background-color: #cccccc; text-align: center; padding: 5px;">NOTICE</div> Changing this parameter affects the settings of other parameters.
<i>Parameter 1-30 Stator Resistance (Rs)</i>	0–99.990 Ω	Size related	Set the stator resistance value.
<i>Parameter 1-37 d-axis Inductance (Ld)</i>	0.000–1000.000 mH	Size related	Enter the value of the d-axis inductance. Obtain the value from the permanent magnet motor datasheet.
<i>Parameter 1-38 q-axis Inductance (Lq)</i>	0.000–1000.000 mH	Size related	Enter the value of the q-axis inductance.
<i>Parameter 1-39 Motor Poles</i>	2–100	4	Enter the number of motor poles.
<i>Parameter 1-40 Back EMF at 1000 RPM</i>	10–9000 V	Size related	Line-line RMS back EMF voltage at 1000 RPM.
<i>Parameter 1-42 Motor Cable Length</i>	0–100 m	50 m	Enter the motor cable length.
<i>Parameter 1-44 d-axis Inductance Sat. (LdSat)</i>	0.000–1000.000 mH	Size related	This parameter corresponds to the inductance saturation of Ld. Ideally, this parameter has the same value as <i>parameter 1-37 d-axis Inductance (Ld)</i> . However, if the motor supplier provides an induction curve, enter the induction value, which is 200% of the nominal current.
<i>Parameter 1-45 q-axis Inductance Sat. (LqSat)</i>	0.000–1000.000 mH	Size related	This parameter corresponds to the inductance saturation of Lq. Ideally, this parameter has the same value as <i>parameter 1-38 q-axis Inductance (Lq)</i> . However, if the motor supplier provides an induction curve, enter the induction value, which is 200% of the nominal current.

Parameter	Range	Default	Usage
<i>Parameter 1-46 Position Detection Gain</i>	20–200%	100%	Adjusts the height of the test pulse during position detection at start.
<i>Parameter 1-48 Current at Min Inductance for d-axis</i>	20–200%	100%	Enter the inductance saturation point.
<i>Parameter 1-49 Current at Min Inductance for q-axis</i>	20–200%	100%	This parameter specifies the saturation curve of the d- and q-inductance values. From 20–100% of this parameter, the inductances are linearly approximated due to <i>parameter 1-37 d-axis Inductance (Ld)</i> , <i>parameter 1-38 q-axis Inductance (Lq)</i> , <i>parameter 1-44 d-axis Inductance Sat. (LdSat)</i> , and <i>parameter 1-45 q-axis Inductance Sat. (LqSat)</i> .
<i>Parameter 1-70 PM Start Mode</i>	[0] Rotor Detection [1] Parking [3] Rotor Last Position	[1] Parking	Select the PM motor start mode.
<i>Parameter 1-73 Flying Start</i>	[0] Disabled [1] Enabled	[0] Disabled	Select [1] Enabled to enable the drive to catch a spinning motor.
<i>Parameter 3-41 Ramp 1 Ramp Up Time</i>	0.05–3600.0 s	Size related	Ramp-up time from 0 to rated <i>parameter 1-23 Motor Frequency</i> .
<i>Parameter 3-42 Ramp 1 Ramp Down Time</i>	0.05–3600.0 s	Size related	Ramp-down time from rated <i>parameter 1-23 Motor Frequency</i> to 0.
<i>Parameter 4-12 Motor Speed Low Limit [Hz]</i>	0.0–400.0 Hz	0.0 Hz	Enter the minimum limit for low speed.
<i>Parameter 4-14 Motor Speed High Limit [Hz]</i>	0.0–400.0 Hz	100.0 Hz	Enter the maximum limit for high speed.
<i>Parameter 4-19 Max Output Frequency</i>	0.0–400.0 Hz	100.0 Hz	Enter the maximum output frequency value. If <i>parameter 4-19 Max Output Frequency</i> is set lower than <i>parameter 4-14 Motor Speed High Limit [Hz]</i> , <i>parameter 4-14 Motor Speed High Limit [Hz]</i> is set equal to <i>parameter 4-19 Max Output Frequency</i> automatically.
<i>Parameter 30-22 Locked Rotor Detection</i>	[0] Off [1] On	[0] Off	–
<i>Parameter 30-23 Locked Rotor Detection Time [s]</i>	0.05–1.00 s	0.10 s	–

3.2.2.6 Changes Made Function

The changes made function lists all parameters changed from default settings.

- The list shows only parameters that have been changed in the current edit setup.
- Parameters that have been reset to default values are not listed.
- The message *Empty* indicates that no parameters have been changed.

3.2.2.7 Changing Parameter Settings

Procedure

1. To enter the Quick Menu, press the [Menu] key until the indicator in the display is placed above Quick Menu.
2. Press [▲] [▼] to select the wizard, closed-loop setup, motor setup, or changes made.
3. Press [OK].
4. Press [▲] [▼] to browse through the parameters in the Quick Menu.
5. Press [OK] to select a parameter.
6. Press [▲] [▼] to change the value of a parameter setting.
7. Press [OK] to accept the change.
8. Press either [Back] twice to enter Status, or press [Menu] once to enter the Main Menu.

3.2.2.8 Accessing All Parameters via the Main Menu

Procedure

1. Press the [Menu] key until the indicator in the display is placed above Main Menu.
2. Press [▲] [▼] to browse through the parameter groups.
3. Press [OK] to select a parameter group.
4. Press [▲] [▼] to browse through the parameters in the specific group.
5. Press [OK] to select the parameter.
6. Press [▲] [▼] to set/change the parameter value.
7. Press [OK] to accept the change.

3.2.3 Main Menu

Press [Menu] to access the main menu and program all parameters. The main menu parameters can be accessed readily unless a password has been created via *parameter 0-60 Main Menu Password*.

For most applications, it is not necessary to access the main menu parameters. The quick menu provides the simplest and quickest access to the typical required parameters.

3.3 Quick Transfer of Parameter Settings between Multiple Drives

When the set-up of a drive is completed, store the data in the LCP. Then connect the LCP to another drive and copy the parameter settings to the new drive.

3.3.1 Transferring Data from the Drive to the LCP

Procedure

1. Go to *parameter 0-50 LCP Copy*.
2. Press [OK].
3. Select [1] *All to LCP*.
4. Press [OK].

3.3.2 Transferring Data from the LCP to the Drive

Procedure

1. Go to *parameter 0-50 LCP Copy*.
2. Press [OK].
3. Select [2] *All from LCP*.
4. Press [OK].

3.4 Readout and Programming of Indexed Parameters

Procedure

1. Select the parameter and press [OK].
2. Press [▲]/[▼] to scroll through the indexed values.
3. To change the parameter value, select the indexed value and press [OK].
4. Change the value by pressing [▲]/[▼].
5. Press [OK] or [Cancel] to accept or abort the new setting.
6. Press [Back] to leave the parameter.

3.5 Initialization to Default Settings

There are 2 ways to initialize the drive to the default settings.

- Recommended initialization
- Two-finger initialization

Initialization of parameters is confirmed by *alarm 80, Drive initialised* in the display after the power cycle.

3.5.1 Recommended Initialization

Procedure

1. Select *parameter 14-22 Operation Mode*.
2. Press [OK].
3. Select *[2] Initialisation* and press [OK].
4. Power off the drive and wait until the display turns off.
5. Reconnect the mains supply. The drive is now reset, except for the following parameters.

- *Parameter 1-06 Clockwise Direction*
- *Parameter 8-30 Protocol*
- *Parameter 8-31 Address*
- *Parameter 8-32 Baud Rate*
- *Parameter 8-33 Parity / Stop Bits*
- *Parameter 8-35 Minimum Response Delay*
- *Parameter 8-36 Maximum Response Delay*
- *Parameter 8-37 Maximum Inter-char delay*
- *Parameter 8-70 BACnet Device Instance*
- *Parameter 8-72 MS/TP Max Masters*
- *Parameter 8-73 MS/TP Max Info Frames*
- *Parameter 8-74 "I am" Service*
- *Parameter 8-75 Initialisation Password*
- *Parameter 15-00 Operating hours to parameter 15-05 Over Volt's*
- *Parameter 15-03 Power Up's*
- *Parameter 15-04 Over Temp's*
- *Parameter 15-05 Over Volt's*
- *Parameter 15-30 Alarm Log: Error Code*
- *Parameter group 15-4* Drive identification*
- *Parameter 18-10 FireMode Log:Event*

3.5.2 Two-finger Initialization

Procedure

1. Power off the drive.
2. Press [OK] and [Menu].
3. Power up the drive while still pressing the keys for 10 s.

4. The drive is now reset, except for the following parameters.

- *Parameter 1-06 Clockwise Direction*
- *Parameter 15-00 Operating hours*
- *Parameter 15-03 Power Up's*
- *Parameter 15-04 Over Temp's*
- *Parameter 15-05 Over Volt's*
- *Parameter group 15-4* Drive identification*
- *Parameter 18-10 FireMode Log:Event*

4 Parameters

4.1 Parameter List

Table 9: Parameter List

0-** Operation/Display	1-17 Voltage time const.	1-66 Min. Current at Low Speed	3-52 Ramp 2 Ramp Down Time
0-0* Basic Settings	1-2* Motor Data	1-7* Start Adjustments	3-8* Other Ramps
0-01 Language	1-20 Motor Power	1-70 Start Mode	3-80 Jog Ramp Time
0-03 Regional Settings	1-22 Motor Voltage	1-71 Start Delay	3-81 Quick Stop Ramp Time
0-04 Operating State at Power-up	1-23 Motor Frequency	1-72 Start Function	4-** Limits / Warnings
0-06 GridType	1-24 Motor Current	1-73 Flying Start	4-1* Motor Limits
0-07 Auto DC Braking	1-25 Motor Nominal Speed	1-8* Stop Adjustments	4-10 Motor Speed Direction
0-1* Set-up Operations	1-26 Motor Cont. Rated Torque	1-80 Function at Stop	4-12 Motor Speed Low Limit [Hz]
0-10 Active Set-up	1-29 Automatic Motor Adaptation (AMA)	1-82 Min Speed for Function at Stop [Hz]	4-14 Motor Speed High Limit [Hz]
0-11 Programming Set-up	1-3* Adv. Motor Data	1-88 AC Brake Gain	4-18 Current Limit
0-12 Link Setups	1-30 Stator Resistance (Rs)	1-9* Motor Temperature	4-19 Max Output Frequency
0-16 Application Selection	1-31 Rotor Resistance (Rr)	1-90 Motor Thermal Protection	4-4* Adj. Warnings 2
0-3* LCP Custom Readout	1-33 Stator Leakage Reactance (X1)	1-93 Thermistor Source	4-40 Warning Freq. Low
0-30 Custom Readout Unit	1-35 Main Reactance (Xh)	2-** Brakes	4-41 Warning Freq. High
0-31 Custom Readout Min Value	1-37 d-axis Inductance (Ld)	2-0* DC-Brake	4-5* Adj. Warnings
0-32 Custom Readout Max Value	1-38 q-axis Inductance (Lq)	2-00 DC Hold/Motor Preheat Current	4-50 Warning Current Low
0-37 Display Text 1	1-39 Motor Poles	2-01 DC Brake Current	4-51 Warning Current High
0-38 Display Text 2	1-4* Adv. Motor Data II	2-02 DC Braking Time	4-54 Warning Reference Low
0-39 Display Text 3	1-40 Back EMF at 1000 RPM	2-04 DC Brake Cut In Speed	4-55 Warning Reference High
0-4* LCP Keypad	1-42 Motor Cable Length	2-06 Parking Current	4-56 Warning Feedback Low
0-40 [Hand on] Key on LCP	1-43 Motor Cable Length Feet	2-07 Parking Time	4-57 Warning Feedback High
0-42 [Auto on] Key on LCP	1-44 d-axis Inductance Sat. (LdSat)	2-1* Brake Energy Funct.	4-58 Missing Motor Phase Function
0-44 [Off/Reset] Key on LCP	1-45 q-axis Inductance Sat. (LqSat)	2-10 Brake Function	4-6* Speed Bypass
0-5* Copy/Save	1-46 Position Detection Gain	2-16 AC Brake, Max current	4-61 Bypass Speed From [Hz]
0-50 LCP Copy	1-48 Current at Min Inductance for d-axis	2-17 Over-voltage Control	4-63 Bypass Speed To [Hz]
0-51 Set-up Copy	1-49 Current at Min Inductance for q-axis	2-19 Over-voltage Gain	4-64 Semi-Auto Bypass Set-up
0-6* Password	1-5* Load Indep. Setting	3-** Reference / Ramps	5-** Digital In/Out
0-60 Main Menu Password	1-50 Motor Magnetisation at Zero Speed	3-0* Reference Limits	5-0* Digital I/O mode
0-61 Access to Main Menu w/o Password	1-52 Min Speed Normal Magnetising [Hz]	3-02 Minimum Reference	5-00 Digital Input Mode
1-** Load and Motor	1-55 U/f Characteristic - U	3-03 Maximum Reference	5-01 Terminal 27 Mode
1-0* General Settings	1-56 U/f Characteristic - F	3-1* References	5-02 Terminal 29 Mode
1-00 Configuration Mode	1-6* Load Depen. Setting	3-10 Preset Reference	5-03 Digital Input 29 Mode
1-01 Motor Control Principle	1-62 Slip Compensation	3-11 Jog Speed [Hz]	5-1* Digital Inputs
1-03 Torque Characteristics	1-63 Slip Compensation Time Constant	3-14 Preset Relative Reference	5-10 Terminal 18 Digital Input
1-06 Clockwise Direction	1-64 Resonance Dampening	3-15 Reference 1 Source	5-11 Terminal 19 Digital Input
1-08 Motor Control Bandwidth	1-65 Resonance Dampening Time Constant	3-16 Reference 2 Source	5-12 Terminal 27 Digital Input
1-1* Motor Selection		3-17 Reference 3 Source	5-13 Terminal 29 Digital Input
1-10 Motor Construction		3-4* Ramp 1	5-3* Digital Outputs
1-14 Damping Gain		3-41 Ramp 1 Ramp Up Time	5-30 Terminal 27 Digital Output
1-15 Low Speed Filter Time Const.		3-42 Ramp 1 Ramp Down Time	5-31 Terminal 29 Digital Output
1-16 High Speed Filter Time Const.		3-5* Ramp 2	5-34 On Delay, Digital Output
		3-51 Ramp 2 Ramp Up Time	

Table 10: Parameter List

5-35 Off Delay, Digital Output	6-71 Terminal 45 Analog Output	8-70 BACnet Device Instance	14-11 Mains Fault Voltage Level
5-4* Relays	6-72 Terminal 45 Digital Output	8-72 MS/TP Max Masters	14-12 Response to Mains Imbalance
5-40 Function Relay	6-73 Terminal 45 Output Min Scale	8-73 MS/TP Max Info Frames	14-15 Kin. Back-up Trip Recovery Level
5-41 On Delay, Relay	6-74 Terminal 45 Output Max Scale	8-74 "I am" Service	14-2* Reset Functions
5-42 Off Delay, Relay	6-76 Terminal 45 Output Bus Control	8-75 Intialisation Password	14-20 Reset Mode
5-5* Pulse Input	6-9* Analog/Digital Output 42	8-79 Protocol Firmware version	14-21 Automatic Restart Time
5-50 Term. 29 Low Frequency	6-90 Terminal 42 Mode	8-8* FC Port Diagnostics	14-22 Operation Mode
5-51 Term. 29 High Frequency	6-91 Terminal 42 Analog Output	8-80 Bus Message Count	14-23 Typecode Setting
5-52 Term. 29 Low Ref./Feedb. Value	6-92 Terminal 42 Digital Output	8-81 Bus Error Count	14-27 Action At Inverter Fault
5-53 Term. 29 High Ref./Feedb. Value	6-93 Terminal 42 Output Min Scale	8-82 Slave Messages Rcvd	14-28 Production Settings
5-8* I/O Options	6-94 Terminal 42 Output Max Scale	8-83 Slave Error Count	14-29 Service Code
5-80 AHF Cap Reconnect Delay	6-96 Terminal 42 Output Bus Control	8-84 Slave Messages Sent	14-3* Current Limit Ctrl.
5-9* Bus Controlled	6-98 Drive Type	8-85 Slave Timeout Errors	14-30 Current Lim Ctrl, Proportional Gain
5-90 Digital & Relay Bus Control	8-** Comm. and Options	8-88 Reset FC port Diagnostics	14-31 Current Lim Ctrl, Integration Time
6-** Analog In/Out	8-0* General Settings	8-9* Bus Feedback	14-32 Current Lim Ctrl, Filter Time
6-0* Analog I/O Mode	8-01 Control Site	8-94 Bus Feedback 1	14-4* Energy Optimising
6-00 Live Zero Timeout Time	8-02 Control Source	8-95 Bus Feedback 2	14-40 VT Level
6-01 Live Zero Timeout Function	8-03 Control Timeout Time	13-** Smart Logic	14-41 AEO Minimum Magnetisation
6-02 Fire Mode Live Zero Timeout Function	8-04 Control Timeout Function	13-0* SLC Settings	14-44 d-axis current optimization for IPM
6-1* Analog Input 53	8-3* FC Port Settings	13-00 SL Controller Mode	14-5* Environment
6-10 Terminal 53 Low Voltage	8-30 Protocol	13-01 Start Event	14-50 RFI Filter
6-11 Terminal 53 High Voltage	8-31 Address	13-02 Stop Event	14-51 DC-Link Voltage Compensation
6-12 Terminal 53 Low Current	8-32 Baud Rate	13-03 Reset SLC	14-52 Fan Control
6-13 Terminal 53 High Current	8-33 Parity/Stop Bits	13-1* Comparators	14-53 Fan Monitor
6-14 Terminal 53 Low Ref./Feedb. Value	8-35 Minimum Response Delay	13-10 Comparator Operand	14-55 Output Filter
6-15 Terminal 53 High Ref./Feedb. Value	8-36 Maximum Response Delay	13-11 Comparator Operator	14-6* Auto Derate
6-16 Terminal 53 Filter Time Constant	8-37 Maximum Inter-char delay	13-12 Comparator Value	14-61 Function at Inverter Overload
6-19 Terminal 53 mode	8-4* FC MC protocol set	13-2* Timers	14-63 Min Switch Frequency
6-2* Analog Input 54	8-42 PCD Write Configuration	13-20 SL Controller Timer	14-64 Dead Time Compensation Zero Current Level
6-20 Terminal 54 Low Voltage	8-43 PCD Read Configuration	13-4* Logic Rules	14-65 Speed Derate Dead Time Compensation
6-21 Terminal 54 High Voltage	8-5* Digital/Bus	13-40 Logic Rule Boolean 1	14-9* Fault Settings
6-22 Terminal 54 Low Current	8-50 Coasting Select	13-41 Logic Rule Operator 1	14-90 Fault Level
6-23 Terminal 54 High Current	8-51 Quick Stop Select	13-42 Logic Rule Boolean 2	15-** Drive Information
6-24 Terminal 54 Low Ref./Feedb. Value	8-52 DC Brake Select	13-43 Logic Rule Operator 2	15-0* Operating Data
6-25 Terminal 54 High Ref./Feedb. Value	8-53 Start Select	13-44 Logic Rule Boolean 3	15-00 Operating hours
6-26 Terminal 54 Filter Time Constant	8-54 Reversing Select	13-5* States	15-01 Running Hours
6-29 Terminal 54 mode	8-55 Set-up Select	13-51 SL Controller Event	15-02 kWh Counter
6-7* Analog/Digital Output 45	8-56 Preset Reference Select	13-52 SL Controller Action	15-03 Power Up's
6-70 Terminal 45 Mode	8-7* BACnet	14-** Special Functions	15-04 Over Temp's
		14-0* Inverter Switching	15-05 Over Volt's
		14-01 Switching Frequency	
		14-03 Overmodulation	
		14-07 Dead Time Compensation Level	
		14-08 Damping Gain Factor	
		14-09 Dead Time Bias Current Level	
		14-1* Mains Failure	
		14-10 Mains Failure	

Table 11: Parameter List

15-06 Reset kWh Counter	16-34 Heatsink Temp.	20-** Drive Closed Loop	22-34 Low Speed Power [kW]
15-07 Reset Running Hours Counter	16-35 Inverter Thermal	20-0* Feedback	22-37 High Speed [Hz]
15-3* Alarm Log	16-36 Inv. Nom. Current	20-00 Feedback 1 Source	22-38 High Speed Power [kW]
15-30 Alarm Log: Error Code	16-37 Inv. Max. Current	20-01 Feedback 1 Conversion	22-4* Sleep Mode
15-31 InternalFaultReason	16-38 SL Controller State	20-03 Feedback 2 Source	22-40 Minimum Run Time
15-32 Alarm Log: Time	16-5* Ref. & Feedb.	20-04 Feedback 2 Conversion	22-41 Minimum Sleep Time
15-4* Drive Identification	16-50 External Reference	20-06 Feedback 3 Source	22-43 Wake-Up Speed [Hz]
15-40 FC Type	16-52 Feedback[Unit]	20-07 Feedback 3 Conversion	22-44 Wake-Up Ref./FB Diff
15-41 Power Section	16-54 Feedback 1 [Unit]	20-12 Reference/Feedback Unit	22-45 Setpoint Boost
15-42 Voltage	16-55 Feedback 2 [Unit]	20-2* Feedback/Setpoint	22-46 Maximum Boost Time
15-43 Software Version	16-56 Feedback 3 [Unit]	20-20 Feedback Function	22-47 Sleep Speed [Hz]
15-44 Ordered TypeCode	16-6* Inputs & Outputs	20-21 Setpoint 1	22-48 Sleep Delay Time
15-45 Actual Typecode String	16-60 Digital Input	20-6* Sensorless	22-49 Wake-Up Delay Time
15-46 Drive Ordering No	16-61 Terminal 53 Setting	20-60 Sensorless Unit	22-5* End of Curve
15-48 LCP Id No	16-62 Analog input 53	20-69 Sensorless Information	22-50 End of Curve Function
15-49 SW ID Control Card	16-63 Terminal 54 Setting	20-7* PI Autotuning	22-51 End of Curve Delay
15-50 SW ID Power Card	16-64 Analog input 54	20-70 Closed Loop Type	22-6* Broken Belt Detection
15-51 Drive Serial Number	16-65 Analog output 42 [mA]	20-71 PI Performance	22-60 Broken Belt Function
15-52 OEM Information	16-66 Digital Output	20-72 PI Output Change	22-61 Broken Belt Torque
15-53 Power Card Serial Number	16-67 Pulse input 29 [Hz]	20-73 Minimum Feedback Level	22-62 Broken Belt Delay
15-57 File Version	16-71 Relay output	20-74 Maximum Feedback Level	22-8* Flow Compensation
15-59 Filename	16-72 Counter A	20-79 PI Autotuning	22-80 Flow Compensation
15-9* Parameter Info	16-73 Counter B	20-8* PI Basic Settings	22-81 Square-linear Curve Approximation
15-92 Defined Parameters	16-79 Analog output 45 [mA]	20-81 PI Normal/ Inverse Control	22-82 Work Point Calculation
15-97 Application Type	16-8* Fieldbus & FC Port	20-83 PI Start Speed [Hz]	22-84 Speed at No-Flow [Hz]
15-98 Drive Identification	16-86 FC Port REF 1	20-84 On Reference Bandwidth	22-86 Speed at Design Point [Hz]
16-** Data Readouts	16-9* Diagnosis Readouts	20-9* PI Controller	22-87 Pressure at No-Flow Speed
16-0* General Status	16-90 Alarm Word	20-91 PI Anti Windup	22-88 Pressure at Rated Speed
16-00 Control Word	16-91 Alarm Word 2	20-93 PI Proportional Gain	22-89 Flow at Design Point
16-01 Reference [Unit]	16-92 Warning Word	20-94 PI Integral Time	22-90 Flow at Rated Speed
16-02 Reference [%]	16-93 Warning Word 2	20-97 PI Feed Forward Factor	23-** Time-based Functions
16-03 Status Word	16-94 Ext. Status Word	22-** Appl. Functions	23-0* Timed Interval Running Settings
16-05 Main Actual Value [%]	16-95 Ext. Status Word 2	22-0* Miscellaneous	23-05 Interval between operation
16-09 Custom Readout	16-97 Alarm Word 3	22-01 Power Filter Time	23-06 Running time
16-1* Motor Status	16-98 Warning Word 3	22-02 Sleepmode CL Control Mode	23-07 Running speed and direction
16-10 Power [kW]	18-** Info & Readouts	22-04 Check Valve Monitor	24-** Appl. Functions 2
16-11 Power [hp]	18-1* Fire Mode Log	22-2* No-Flow Detection	24-0* Fire Mode
16-12 Motor Voltage	18-10 FireMode Log:Event	22-23 No-Flow Function	24-00 FM Function
16-13 Frequency	18-5* Ref. & Feedb.	22-24 No-Flow Delay	24-01 Fire Mode Configuration
16-14 Motor current	18-50 Sensorless Readout [unit]	22-26 Dry Pump Function	24-03 Fire Mode Min Reference
16-15 Frequency [%]	18-8* Compatibility	22-27 Dry Pump Delay	24-04 Fire Mode Max Reference
16-16 Torque [Nm]	18-87 Inv. Max. Current	22-3* No-Flow Power Tuning	24-05 FM Preset Reference
16-17 Speed [RPM]	18-88 Motor current	22-30 No-Flow Power	
16-18 Motor Thermal	18-9* PID Readouts	22-31 Power Correction Factor	
16-22 Torque [%]	18-90 Process PID Error	22-33 Low Speed [Hz]	
16-26 Power Filtered [kW]	18-91 Process PID Output		
16-27 Power Filtered [hp]	18-92 Process PID Clamped Output		
16-3* Drive Status	18-93 Process PID Gain Scaled Output		
16-30 DC Link Voltage			

Table 12: Parameter List

24-06 Fire Mode Reference Source	25-06 Number of Pumps	25-45 Staging Speed [Hz]	25-8* Status
24-07 Fire Mode Feedback Source	25-2* Bandwidth Settings	25-47 Destaging Speed [Hz]	25-80 Cascade Status
24-08 Mul FM Preset Reference	25-20 Staging Bandwidth	25-5* Alternation Settings	25-81 Pump Status
24-09 FM Alarm Handling	25-21 Override Bandwidth	25-50 Lead Pump Alternation	25-82 Lead Pump
24-1* Drive Bypass	25-22 Fixed Speed Bandwidth	25-51 Alternation Event	25-84 Pump ON Time
24-10 Drive Bypass Function	25-23 SBW Staging Delay	25-52 Alternation Time Interval	25-9* Service
24-11 Drive Bypass Delay Time	25-24 SBW Destaging Delay	25-53 Alternation Timer Value	25-90 Pump Interlock
25-** Cascade Controller	25-25 OBW Time	25-55 Alternate if Load <= 50%	30-** Special Features
25-0* System Settings	25-27 Stage Function	25-56 Staging Mode at Alternation	30-2* Adv. Start Adjust
25-00 Cascade Controller	25-28 Stage Function Time	25-57 Relays per Pump	30-22 Locked Rotor Protection
25-04 Pump Cycling	25-29 Destage Function	25-58 Run Next Pump Delay	30-23 Locked Rotor Detection Time [s]
25-05 Fixed Lead Pump	25-30 Destage Function Time	25-59 Run on Mains Delay	30-5* Unit Configuration
	25-4* Staging Settings		30-58 LockPassword
	25-42 Staging Threshold		
	25-43 Destaging Threshold		

4.2 Parameter Group 0-** Operation / Display

Parameters related to the fundamental functions of the drive, function of the LCP buttons and configuration of the LCP display.

4.2.1 0-0* Basic Settings

Parameter group for basic drive settings.

0-01 Language

Default value: [0] English	Parameter type: Option	2-setup: 1 setup
Conversion index: -	Data type: u_int8	Change during operation: True

Select the language to be used in the display.

Table 13: Option:

[0]	English
[10]	Chinese

0-03 Regional Settings

Default value: [0] International	Parameter type: Option	2-setup: 1 setup
Conversion index: -	Data type: u_int8	Change during operation: False

To meet the needs for different default settings in different parts of the world, *parameter 0-03 Regional Settings* is implemented in the drive. The selected setting influences the default setting of the motor nominal frequency.

Table 14: Option:

[0]	International	Set the default value of <i>parameter 1-23 Motor Frequency</i> to 50 Hz.
[1]	North America	Set the default value of <i>parameter 1-23 Motor Frequency</i> to 60 Hz.

0-04 Operating State at Power-up

Default value: [0] Resume	Parameter type: Option	2-setup: All setups
Conversion index: -	Data type: u_int8	Change during operation: True

Select the operating mode after reconnection of the drive to mains voltage after power-down when operating in Hand (local) mode.

Table 15: Option:

[0]	Resume	Resumes operation of the drive, maintaining the same local reference and the same start/stop condition (applied by [Hand On]/[Off] on the LCP or local start via a digital input) as before the drive was powered down.
[1]	Forced stop, ref=old	Uses saved reference [1] to stop the drive, but at the same time retains the local speed reference in memory before powering down. After mains voltage is reconnected, and after receiving a start command (pressing [Hand On] key or using the local start command via a digital input), the drive restarts and operates at the retained speed reference.

0-06 GridType

Default value: [Configuration dependent]	Parameter type: Option	2-setup: 1 setup
Conversion index: -	Data type: u_int8	Change during operation: False

Select the grid type of the supply voltage/frequency.

N O T I C E

Not all options are supported in all power sizes.

IT Grid is a supply mains, where there are no connections to ground.

Delta is a supply mains where the secondary part of the transformer is delta connected and 1 phase is connected to ground.

Table 16: Option:

[10]	380-440V/50Hz/IT-grid
[11]	380-440V/50Hz/Delta
[12]	380-440V/50Hz
[20]	440-480V/50Hz/IT-grid
[21]	440-480V/50Hz/Delta
[22]	440-480V/50Hz
[110]	380-440V/60Hz/IT-grid
[111]	380-440V/60Hz/Delta
[112]	380-440V/60Hz
[120]	440-480V/60Hz/IT-grid
[121]	440-480V/60Hz/Delta
[122]	440-480V/60Hz

0-07 Auto DC Braking

Default value: [1] On	Parameter type: Option	2-setup: 1 setup
Conversion index: -	Data type: u_int8	Change during operation: False

Protective function against over voltage at coast in IT grid environment. This parameter is active only when [1] On is selected in this parameter, and IT-grid options are selected in *parameter 0-06 GridType*.

Table 17: Option:

[0]	Off	This function is not active.
[1]	On	This function is active.

4.2.2 0-1* Define and Setup Operations

A complete set of all parameters controlling the drive is called a setup. A fixed set of factory settings can be copied into 1 or more setups.

Some of the advantages of having more than 1 setup in the drive are:

- Run the motor in 1 setup (active setup) while updating parameters in another setup (edit setup).
- Connect the 2 motors (1 at a time) to the drive. Motor data for the 2 motors can be placed in the 2 setups.
- Rapidly change settings of the drive and/or the motor while the motor is running. For example, ramp time or preset references via bus or digital inputs.

The active setup can be set as multi setup, where the active setup is selected via input on a digital input terminal and/or via the bus control word.

To copy a setup to other setup, use *parameter 0-51 Set-up Copy*. To avoid conflicting settings of the same parameter within different setups, link the setups using *parameter 0-12 Link Setups*. Stop the drive before switching between setups where parameters marked *not changeable during operation* have different values.

0-10 Active Set-up

Default value: [1] Set-up 1	Parameter type: Option	2-setup: 1 setup
Conversion index: -	Data type: u_int8	Change during operation: True

Select the setup to control the drive functions. Use Multi setup for remote selection.

Table 18: Option:

[1]	Set-up 1	Setup 1 is active.
[2]	Set-up 2	Setup 2 is active.
[9]	Multi Setup	Used for remote setup selections via digital inputs and the serial communication port. This setup uses the settings from <i>parameter 0-12 Link Setups</i> .

0-11 Programming Set-up

Default value: [9] Active Set-up	Parameter type: Option	2-setup: 1 setup
Conversion index: -	Data type: u_int8	Change during operation: True

Select the setup to be edited. It indicates the setup being programmed by LCP when it is accessed by LCP. It indicates the setup being programmed by RS485 when accessed by RS485, and so on for other channels like fieldbus, USB, and so on.

Table 19: Option:

[1]	Set-up 1	Edit setup 1.
[2]	Set-up 2	Edit setup 2.
[9]	Active Set-up	Edit parameters in the setup selected via digital I/Os.

0-12 Link Setups

Default value: [20] Linked	Parameter type: Option	2-setup: All setups
Conversion index: -	Data type: u_int8	Change during operation: False

If the setups are not linked, a change between them is not possible while the motor is running.

Table 20: Option:

[0]	Not linked	When selecting a different setup for operation, the setup change does not occur until the motor is coasted.
[20]	Linked	Copy <i>not changeable during operation</i> parameters from 1 setup to the other. It is possible to switch setups while the motor is running.

0-16 Application Selection

Default value: [0] None	Parameter type: Option	2-setup: 1 setup
Conversion index: -	Data type: u_int8	Change during operation: False

Select an application function from the options. When an application is selected, a set of its related parameters are set automatically.

NOTICE

Before selecting an option in *parameter 0-16 Application Selection*, set [2] *Initialisation* for *parameter 14-22 Operation Mode* to ensure that all parameter values are reset to default settings.

Table 21: Option:

[0]	None
[12]	Open Loop Control
[13]	Process Closed Loop Control
[14]	Constant Pressure Water Supply
[15]	Multi Pump Control Application

4.2.3 0-3* LCP Custom Readout

Parameters for configuring the custom readout value and defining custom display texts. It is possible to customize the display elements for various purposes.

Custom readout

The calculated value to be shown is based on settings in *parameter 0-30 Custom Readout Unit*, *parameter 0-31 Custom Readout Min Value* (linear only), *parameter 0-32 Custom Readout Max Value*, *parameter 4-14 Motor Speed High Limit [Hz]*, and actual speed.

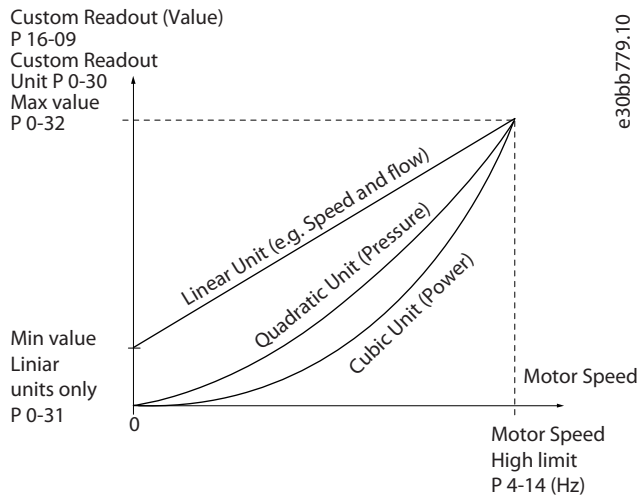

Illustration 6: Custom Readout

The relation depends on the type of unit selected in *parameter 0-30 Custom Readout Unit*:

Table 22: Speed Relation

Unit type	Speed relation
Dimensionless	Linear
Speed	
Flow, volume	

Unit type	Speed relation
Flow, mass	
Velocity	
Length	
Temperature	
Pressure	Quadratic
Power	Cubic

0-30 Custom Readout Unit

Default value: [1] %	Parameter type: Option	2-setup: 1 setup
Conversion index: -	Data type: u_int8	Change during operation: True

Set the unit to be used for Custom Readout Value.

Table 23: Option:

[0]	None
[1]	%
[5]	PPM
[10]	l/Min
[11]	RPM
[12]	Pulse/s
[20]	l/s
[21]	l/min
[22]	l/h
[23]	m ³ /s
[24]	m ³ /min
[25]	m ³ /h
[30]	kg/s
[31]	kg/min
[32]	kg/h
[33]	t/min
[34]	t/h
[40]	m/s
[41]	m/min
[45]	m
[60]	Degree Celsius

[70]	mbar
[71]	bar
[72]	Pa
[73]	kPa
[74]	m Wg
[80]	kW
[120]	GPM
[121]	gal/s
[122]	gal/min
[123]	gal/h
[124]	CFM
[127]	ft ³ /h
[140]	ft/s
[141]	ft/min
[160]	Degree Fahr
[170]	psi
[171]	lb/in ²
[172]	in WG
[173]	ft WG
[180]	hp

0-31 Custom Readout Min Value

Default value: 0	Parameter type: Range	2-setup: 1 setup
Conversion index: -2	Data type: int32	Change during operation: True

This parameter sets the minimum value of the custom defined readout (occurs at 0 speed). It is only possible to select a value different from 0 when selecting a linear unit in *parameter 0-30 Custom Readout Unit*. For quadratic and cubic units, the minimum value is 0.

Table 24: Range:

Min: 0	Max: 999999.99 CustomReadoutUnit	Default value: 0 CustomReadoutUnit
--------	----------------------------------	------------------------------------

0-32 Custom Readout Max Value

Default value: 100	Parameter type: Range	2-setup: 1 setup
Conversion index: -2	Data type: int32	Change during operation: True

This parameter sets the maximum value to be shown when the speed of the motor has reached the set value for *parameter 4-14 Motor Speed High Limit [Hz]*.

Table 25: Range:

Min: 0.0	Max: 999999.99 CustomReadoutUnit	Default value: 100 CustomReadoutUnit
----------	----------------------------------	--------------------------------------

0-37 Display Text 1

Default value: N/A	Parameter type: Range	2-setup: 1 setup
Conversion index: -	Data type: VisibleString	Change during operation: True

Use this parameter to write an individual text string to be read via serial communication. Device ID can be included. Only used when running BACnet.

Table 26: Range:

Min: 0	Max: 0	Default value: N/A
--------	--------	--------------------

0-38 Display Text 2

Default value: N/A	Parameter type: Range	2-setup: 1 setup
Conversion index: -	Data type: VisibleString	Change during operation: True

Use this parameter to write an individual text string to be read via serial communication. Only used when running BACnet.

Table 27: Range:

Min: 0	Max: 0	Default value: N/A
--------	--------	--------------------

0-39 Display Text 3

Default value: N/A	Parameter type: Range	2-setup: 1 setup
Conversion index: -	Data type: VisibleString	Change during operation: True

Use this parameter to write an individual text string to be read via serial communication. Only used when running BACnet.

Table 28: Range:

Min: 0	Max: 0	Default value: N/A
--------	--------	--------------------

4.2.4 0-4* LCP Keypad

Enable, disable, and password protect individual keys on the LCP.

0-40 [Hand on] Key on LCP

Default value: [1] Enabled	Parameter type: Option	2-setup: All setups
Conversion index: -	Data type: u_int8	Change during operation: True

Table 29: Option:

[0]	Disabled	To avoid unintended start of the drive in hand-on mode, select [0] Disabled.
[1]	Enabled	[Hand On] is enabled.

0-42 [Auto on] Key on LCP

Default value: [1] Enabled	Parameter type: Option	2-setup: All setups
Conversion index: -	Data type: u_int8	Change during operation: True

Table 30: Option:

[0]	Disabled	To avoid unintended start of the drive, select [0] Disabled.
[1]	Enabled	[Auto On] is enabled.

0-44 [Off/Reset] Key on LCP

Default value: [1] Enabled	Parameter type: Option	2-setup: All setups
Conversion index: -	Data type: u_int8	Change during operation: True

Table 31: Option:

[0]	Disabled	Disable the [Off/Reset] key.
[1]	Enabled	Enable both off and reset functions.
[7]	Enable Reset Only	Enable the reset function, and disable the off function to avoid unintended stop of the drive.

4.2.5 0-5* Copy/Save

Copy parameter settings between setups and to/from the LCP.

0-50 LCP Copy

Default value: [0] No copy	Parameter type: Option	2-setup: 1 setup
Conversion index: -	Data type: u_int8	Change during operation: False

Table 32: Option:

[0]	No copy	No action.
[1]	All to LCP	Copy all parameters in all setups from the drive memory to the LCP memory. For service purposes, copy all parameters to the LCP after commissioning.
[2]	All from LCP	Copy all parameters in all setups from the LCP memory to the drive memory.
[3]	Size indep. from LCP	Copy only the parameters that are independent of the motor size. The latter selection can be used to program several drives with the same function without disturbing motor data that is already set.
[10]	Delete LCP copy data	Delete copied parameters in LCP. This function requires that LCP version is greater than or equal to V11.00.

0-51 Set-up Copy

Default value: [0] No copy	Parameter type: Option	2-setup: 1 setup
Conversion index: -	Data type: u_int8	Change during operation: False

Table 33: Option:

[0]	No copy	No action.
[1]	Copy from setup 1	Copy from setup 1 to setup 2.
[2]	Copy from setup 2	Copy from setup 2 to setup 1.
[9]	Copy from factory setup	Copy factory setting to programming setup (selected in <i>parameter 0-11 Programming Set-up</i>).

4.2.6 0-6* Password

This parameter group defines password to access menus.

0-60 Main Menu Password

Default value: 0	Parameter type: Range	2-setup: 1 setup
Conversion index: -	Data type: u_int16	Change during operation: True

Define the password for access to the Main Menu via the [Main Menu] key. Setting the value to 0 disables the password function. This parameter hides after a password is defined.

Table 34: Range:

Min: 0	Max: 999	Default value: 0
--------	----------	------------------

0-61 Access to Main Menu w/o Password

Default value: [0] Full access	Parameter type: Option	2-setup: 1 setup
Conversion index: -	Data type: u_int8	Change during operation: True

Table 35: Option:

[0]	Full access	Disable the password defined in <i>parameter 0-60 Main Menu Password</i> .
[1]	LCP: Read only	Prevent unauthorized editing of Main Menu parameters.
[2]	LCP: No access	Prevent unauthorized viewing and editing of Main Menu parameters.
[3]	Bus: Read only	Provide read-only access to parameters via fieldbus.
[5]	All: Read only	Prevent unauthorized editing of main menu parameters and provides read-only access to parameters via fieldbus.

4.3 Parameter Group 1-** Load and Motor

Parameters related to the motor nameplate load compensations and application load type.

4.3.1 1-0* General Settings

Define whether the drive operates in speed mode or torque mode; and whether the internal PID control should be active or not.

1-00 Configuration Mode

Default value: [0] Open Loop	Parameter type: Option	2-setup: All setups
Conversion index: -	Data type: u_int8	Change during operation: True

Select the application control principle to be used.

Table 36: Option:

[0]	Open Loop	Motor speed is determined by applying a speed reference or by setting the wanted speed when in hand-on mode. Open loop is also used if the drive is part of a closed-loop control system based on an external PI controller providing a speed reference signal as output.
[3]	Process Closed Loop	<div style="text-align: center; background-color: #cccccc; padding: 5px;">NOTICE</div> <p>When set for closed loop, the commands <i>Reversing</i> and <i>Start Reversing</i> do not reverse the direction of the motor.</p> <p>A reference from the built-in PI controller determines the motor speed. The built-in PI controller varies the motor speed as of a closed-loop control process (for example, constant pressure or flow). Configure the PI controller in <i>parameter group 20-** Drive Closed Loop</i>.</p>

1-01 Motor Control Principle

Default value: [1] VVC ⁺	Parameter type: Option	2-setup: All setups
Conversion index: -	Data type: u_int8	Change during operation: False

Select U/f mode or VVC⁺ mode as motor control principle.

Table 37: Option:

[0]	U/f	<p style="text-align: center;">NOTICE</p> <p>When running U/f, control slip and load compensations are not included.</p> <p>Used for parallel-connected motors and/or special motor applications. Set the U/f settings in <i>parameter 1-55 U/f Characteristic - U</i> and <i>parameter 1-56 U/f Characteristic - F</i>.</p>
[1]	VVC ⁺	<p style="text-align: center;">NOTICE</p> <p>When <i>parameter 1-10 Motor Construction</i> is set to PM-enabled options, only VVC⁺ option is available.</p> <p>Normal running mode, including slip and load compensations.</p>

1-03 Torque Characteristics

Default value: [1] Variable Torque	Parameter type: Option	2-setup: All setups
Conversion index: -	Data type: u_int8	Change during operation: False

Select the torque characteristic. VT and AEO are both energy saving operations.

Table 38: Option:

[1]	Variable Torque	For speed control of centrifugal pumps and fans. Also to be used when controlling more than 1 motor from the same drive (for example, multiple condenser fans or cooling tower fans). Provides a voltage that is optimized for a squared torque load characteristic of the motor.
[3]	Auto Energy Optim.	For optimum energy efficient speed control of centrifugal pumps and fans, it provides a voltage that is optimized for a squared torque load characteristic of the motor. In addition, the AEO feature adapts the voltage exactly to the current load situation, thereby reducing energy consumption and audible noise from the motor.

1-06 Clockwise Direction

Default value: [0] Normal	Parameter type: Option	2-setup: 1 setup
Conversion index: -	Data type: u_int8	Change during operation: False

This parameter defines the term *Clockwise* corresponding to the LCP direction arrow. Used for easy change of direction of shaft rotation without swapping motor wires.

Table 39: Option:

[0]	Normal	The motor shaft turns in clockwise direction when drive is connected U⇒U; V⇒V; and W⇒W to motor.
[1]	Inverse	The motor shaft turns in counterclockwise direction when drive is connected U⇒U; V⇒V; and W⇒W to motor.

1-08 Motor Control Bandwidth

Default value: [1] Medium	Parameter type: Option	2-setup: All setups
Conversion index: -	Data type: u_int8	Change during operation: False

Table 40: Option:

[0]	High	Suitable for highly dynamic response.
[1]	Medium	Suitable for smooth steady-state operation.

[2]	Low	Suitable for smooth steady-state operation with lowest dynamic response.
[3]	Adaptive 1	Suitable for smooth steady-state operation with extra active damping.
[4]	Adaptive 2	This is an alternative to [3] Adaptive 1, which focuses on low-inductance PM motors.

4.3.2 1-1* Motor Selection

Parameter group for setting general motor data. This parameter group cannot be adjusted while the motor is running.

1-10 Motor Construction

Default value: [0] Asynchron	Parameter type: Option	2-setup: All setups
Conversion index: -	Data type: u_int8	Change during operation: False

Select the motor design type.

Table 41: Option:

[0]	Asynchron	For induction motors.
[1]	PM, non salient SPM	For permanent magnet (PM) motors with surface-mounted (non-salient) magnets. Refer to <i>parameter 1-14 Damping Gain</i> to <i>parameter 1-17 Voltage filter time const.</i> for details about optimizing the motor operation.
[3]	PM, salient IPM	For permanent magnet (PM) motors with interior (salient) magnets, with inductance saturation control.

The following parameters are active ('x') depending on the setting of *parameter 1-10 Motor Construction*.

Table 42: Active Parameters

<i>Parameter 1-10 Motor Construction</i>	<i>[0] Asynchron</i>	<i>[1] PM, non salient SPM</i>	<i>[3] PM, salient IPM</i>
<i>Parameter 1-00 Configuration Mode</i>	x	x	x
<i>Parameter 1-03 Torque Characteristics</i>	x		
<i>Parameter 1-06 Clockwise Direction</i>	x	x	x
<i>Parameter 1-08 Motor Control Bandwidth</i>	x	x	x
<i>Parameter 1-14 Damping Gain</i>		x	x
<i>Parameter 1-15 Low Speed Filter Time Const.</i>		x	x
<i>Parameter 1-16 High Speed Filter Time Const.</i>		x	x
<i>Parameter 1-17 Voltage filter time const.</i>		x	x
<i>Parameter 1-20 Motor Power [kW]</i>	x		
<i>Parameter 1-22 Motor Voltage</i>	x		
<i>Parameter 1-23 Motor Frequency</i>	x		
<i>Parameter 1-24 Motor Current</i>	x	x	x
<i>Parameter 1-25 Motor Nominal Speed</i>	x	x	x
<i>Parameter 1-26 Motor Cont. Rated Torque</i>		x	x
<i>Parameter 1-29 Automatic Motor Adaption (AMA)</i>	x	x	x
<i>Parameter 1-30 Stator Resistance (Rs)</i>	x	x	x
<i>Parameter 1-33 Stator Leakage Reactance (X1)</i>	x		

<i>Parameter 1-10 Motor Construction</i>	<i>[0] Asynchron</i>	<i>[1] PM, non salient SPM</i>	<i>[3] PM, salient IPM</i>
<i>Parameter 1-35 Main Reactance (Xh)</i>	x		
<i>Parameter 1-37 d-axis Inductance (Ld)</i>		x	x
<i>Parameter 1-38 q-axis Inductance (Lq)</i>			x
<i>Parameter 1-39 Motor Poles</i>	x	x	x
<i>Parameter 1-40 Back EMF at 1000 RPM</i>		x	x
<i>Parameter 1-42 Motor Cable Length</i>	x	x	x
<i>Parameter 1-43 Motor Cable Length Feet</i>	x	x	x
<i>Parameter 1-44 d-axis Inductance Sat. (LdSat)</i>			x
<i>Parameter 1-45 q-axis Inductance Sat. (LqSat)</i>			x
<i>Parameter 1-46 Position Detection Gain</i>		x	x
<i>Parameter 1-48 Current at Min Inductance for d-axis</i>			x
<i>Parameter 1-49 Current at Min Inductance for q-axis</i>			x
<i>Parameter 1-50 Motor Magnetisation at Zero Speed</i>	x		
<i>Parameter 1-52 Min Speed Normal Magnetising [Hz]</i>	x		
<i>Parameter 1-55 U/f Characteristic - U</i>	x		
<i>Parameter 1-56 U/f Characteristic - F</i>	x		
<i>Parameter 1-62 Slip Compensation</i>	x		
<i>Parameter 1-63 Slip Compensation Time Constant</i>	x		
<i>Parameter 1-64 Resonance Dampening</i>	x		
<i>Parameter 1-65 Resonance Dampening Time Constant</i>	x		
<i>Parameter 1-66 Min. Current at Low Speed</i>		x	x
<i>Parameter 1-70 Start Mode</i>		x	x
<i>Parameter 1-71 Start Delay</i>	x	x	x
<i>parameter 1-72 Start Function</i>	x	x	x
<i>Parameter 1-73 Flying Start</i>	x	x	x
<i>Parameter 1-80 Function at Stop</i>	x	x	x
<i>Parameter 1-90 Motor Thermal Protection</i>	x	x	x
<i>parameter 2-00 DC Hold Current</i>	x	x	x
<i>Parameter 2-01 DC Brake Current</i>	x	x	x
<i>Parameter 2-02 DC Braking Time</i>	x	x	x
<i>Parameter 2-04 DC Brake Cut In Speed [Hz]</i>	x	x	x
<i>Parameter 2-06 Parking Current</i>		x	x

<i>Parameter 1-10 Motor Construction</i>	<i>[0] Asynchron</i>	<i>[1] PM, non salient SPM</i>	<i>[3] PM, salient IPM</i>
<i>Parameter 2-07 Parking Time</i>		x	x
<i>Parameter 2-10 Brake Function</i>	x	x	x
<i>Parameter 2-16 AC brake Max. Current</i>	x		
<i>Parameter 2-17 Over-voltage Control</i>	x	x	x
<i>Parameter 4-10 Motor Speed Direction</i>	x	x	x
<i>Parameter 4-14 Motor Speed High Limit [Hz]</i>	x	x	x
<i>Parameter 4-18 Current Limit</i>	x	x	x
<i>Parameter 4-19 Max Output Frequency</i>	x	x	x
<i>Parameter 4-58 Missing Motor Phase Function</i>	x	x	x
<i>Parameter 14-01 Switching Frequency</i>	x	x	x
<i>Parameter 14-03 Overmodulation</i>	x	x	x
<i>Parameter 14-07 Dead Time Compensation Level</i>	x	x	x
<i>Parameter 14-08 Damping Gain Factor</i>	x	x	x
<i>Parameter 14-09 Dead Time Bias Current Level</i>	x	x	x
<i>Parameter 14-10 Mains Failure</i>	x	x	x
<i>Parameter 14-11 Mains Fault Voltage Level</i>	x	x	x
<i>Parameter 14-12 Function at Mains Imbalance</i>	x	x	x
<i>Parameter 14-27 Action At Inverter Fault</i>	x	x	x
<i>Parameter 14-40 VT Level</i>	x	x	x
<i>Parameter 14-41 AEO Minimum Magnetisation</i>	x	x	x
<i>Parameter 14-44 d-axis current optimization for IPM</i>			x
<i>Parameter 14-50 RFI Filter</i>	x		
<i>Parameter 14-51 DC-Link Voltage Compensation</i>	x	x	x
<i>Parameter 14-55 Output Filter</i>	x	x	x
<i>Parameter 14-64 Dead Time Compensation Zero Current Level</i>	x	x	x
<i>Parameter 14-65 Speed Derate Dead Time Compensation</i>	x	x	x
<i>Parameter 30-22 Locked Rotor Protection</i>		x	x
<i>Parameter 30-23 Locked Rotor Detection Time [s]</i>		x	x

1-14 to 1-17 VVC⁺ PM

The default control parameters for VVC+ PM motor control core are optimized for applications and inertia load in the range of $50 > J_l/J_m > 5$. J_l is load inertia from the application and J_m is machine inertia.

For low inertia applications ($J_l/J_m < 5$), it is recommended that *parameter 1-17 Voltage filter time const.* is increased with a factor of 5–10. Sometimes, *parameter 14-08 Damping Gain Factor* should also be reduced to improve performance and stability.

For high-inertia applications ($J_l/J_m > 50$), increase *parameter 1-15 Low Speed Filter Time Const.* and *parameter 1-16 High Speed Filter Time Const.* to improve performance and stability.

For high load at low speed (<30% of rated speed), it is recommended that *parameter 1-17 Voltage filter time const.* is increased due to non-linearity in the inverter at low speed.

1-14 Damping Gain

Default value: 120%	Parameter type: Range	2-setup: All setups
Conversion index: -	Data type: int16	Change during operation: True

The parameter stabilizes the PM motor to ensure smooth and stable operation. The value of damping gain controls the dynamic performance of the PM motor. Low damping gain results in high dynamic performance and a high value results in a low dynamic performance. The dynamic performance is related to the motor data and load type. If the damping gain is too high or low, the control becomes unstable.

Table 43: Range:

Min: 0%	Max: 250%	Default value: 120%
---------	-----------	---------------------

1-15 Low Speed Filter Time Const.

Default value: 0.01 s	Parameter type: Range	2-setup: All setups
Conversion index: -2	Data type: u_int16	Change during operation: True

High-pass filter damping time constant determines the response time to load steps. Obtain quick control through a short damping time constant. However, if this value is too short, the control becomes unstable. This time constant is used below 10% rated speed.

Table 44: Range:

Min: 0.01 s	Max: 20 s	Default value: 0.01 s
-------------	-----------	-----------------------

1-16 High Speed Filter Time Const.

Default value: 0.01 s	Parameter type: Range	2-setup: All setups
Conversion index: -2	Data type: u_int16	Change during operation: True

High-pass filter damping time constant determines the response time to load steps. Obtain quick control through a short damping time constant. However, if this value is too short, the control becomes unstable. This time constant is used above 10% rated speed.

Table 45: Range:

Min: 0.01 s	Max: 20 s	Default value: 0.01 s
-------------	-----------	-----------------------

1-17 Voltage filter time const.

Default value: 0.01 s	Parameter type: Range	2-setup: All setups
Conversion index: -3	Data type: u_int16	Change during operation: True

Machine supply voltage filter time constant is used for reducing the influence of high-frequency ripples and system resonances in the calculation of machine supply voltage. Without this filter, the ripples in the currents can distort the calculated voltage and affect the stability of the system.

Table 46: Range:

Min: 0.001 s	Max: 1 s	Default value: 0.01 s
--------------	----------	-----------------------

4.3.3 1-2* Motor Data

This parameter group comprises input data from the nameplate on the connected motor.

NOTICE

These parameters cannot be adjusted while the motor is running.

N O T I C E

Changing the value of these parameters affects the setting of other parameters.

1-20 Motor Power

Default value: Configuration dependent	Parameter type: Option	2-setup: All setups
Conversion index: -	Data type: u_int8	Change during operation: False

Enter the nominal motor power in kW/hp according to the motor nameplate data. The default value corresponds to the nominal rated output of the unit.

Table 47: Option:

[2]	0.12 kW - 0.16 hp
[3]	0.18 kW - 0.25 hp
[4]	0.25 kW - 0.33 hp
[5]	0.37 kW - 0.5 hp
[6]	0.55 kW - 0.75 hp
[7]	0.75 kW - 1 hp
[8]	1.1 kW - 1.5 hp
[9]	1.5 kW - 2 hp
[10]	2.2 kW - 3 hp
[11]	3 kW - 4 hp
[12]	3.7 kW - 5 hp
[13]	4 kW - 5.4 hp
[14]	5.5 kW - 7.5 hp
[15]	7.5 kW - 10 hp
[16]	11 kW - 15 hp
[17]	15 kW - 20 hp
[18]	18.5 kW - 25 hp
[19]	22 kW - 30 hp
[20]	30 kW - 40 hp
[21]	37 kW - 50 hp
[22]	45 kW - 60 hp
[23]	55 kW - 75 hp
[24]	75 kW - 100 hp
[25]	90 kW - 120 hp
[26]	110 kW - 150 hp
[27]	132 kW - 180 hp

[28]	160 kW - 215 hp
[29]	200 kW - 270 hp
[30]	250 kW - 340 hp
[31]	315 kW - 425 hp
[32]	355 kW - 480 hp

1-22 Motor Voltage

Default value: Configuration dependent	Parameter type: Range	2-setup: All setups
Conversion index: -	Data type: u_int16	Change during operation: False

Enter the nominal motor voltage according to the motor nameplate data. The default value corresponds to the nominal rated output of the unit.

Table 48: Range:

Min: 50 V	Max: 1000 V	Default value: Configuration dependent
-----------	-------------	--

1-23 Motor Frequency

Default value: Configuration dependent	Parameter type: Range	2-setup: All setups
Conversion index: -	Data type: u_int16	Change during operation: False

Select the motor frequency value from the motor nameplate data.

Table 49: Range:

Min: 20 Hz	Max: 400 Hz	Default value: Configuration dependent
------------	-------------	--

1-24 Motor Current

Default value: Configuration dependent	Parameter type: Range	2-setup: All setups
Conversion index: -2	Data type: u_int32	Change during operation: False

Enter the nominal motor current value from the motor nameplate data. This data is used for calculating motor torque, motor thermal protection, and so on.

Table 50: Range:

Min: 0.01 A	Max: 1000.00 A	Default value: Configuration dependent
-------------	----------------	--

1-25 Motor Nominal Speed

Default value: Configuration dependent	Parameter type: Range	2-setup: All setups
Conversion index: -	Data type: u_int16	Change during operation: False

Enter the nominal motor speed value from the motor nameplate data. This data is used for calculating automatic motor compensations.

Table 51: Range:

Min: 50 RPM	Max: 60000 RPM	Default value: Configuration dependent
-------------	----------------	--

1-26 Motor Cont. Rated Torque

Default value: Configuration dependent	Parameter type: Range	2-setup: All setups
Conversion index: -1	Data type: u_int16	Change during operation: False

This parameter is available only when *parameter 1-10 Motor Construction* is set to options that enable permanent motor mode.

Table 52: Range:

Min: 0.1 Nm	Max: 10000.0 Nm	Default value: Configuration dependent
-------------	-----------------	--

1-29 Automatic Motor Adaption (AMA)

Default value: [0] Off	Parameter type: Option	2-setup: All setups
Conversion index: -	Data type: u_int8	Change during operation: False

The AMA function optimizes dynamic motor performance by automatically optimizing the advanced motor parameters while the motor is stationary.

Table 53: Option:

[0]	Off	No function.
[1]	Enable Complete AMA	When <i>parameter 1-10 Motor Construction</i> is set to [0] <i>Asynchron</i> , perform AMA of <i>parameter 1-30 Stator Resistance (Rs)</i> to <i>parameter 1-35 Main Reactance (Xh)</i> . When <i>parameter 1-10 Motor Construction</i> is set to options that enable permanent motors, perform AMA of <i>parameter 1-30 Stator Resistance (Rs)</i> and <i>parameter 1-37 d-axis Inductance (Ld)</i> for SPM, and <i>parameter 1-30 Stator Resistance (Rs)</i> , <i>parameter 1-37 d-axis Inductance (Ld)</i> , <i>parameter 1-38 q-axis Inductance (Lq)</i> , <i>parameter 1-44 d-axis Inductance Sat. (LdSat)</i> , and <i>parameter 1-45 q-axis Inductance Sat. (LqSat)</i> for IPM.
[2]	Enable Reduced AMA	Performs a reduced AMA of the stator resistance R_s in the system only. Select this option if an LC filter is used between the drive and the motor.

N O T I C E

When *parameter 1-10 Motor Construction* is set to options that enable permanent motor mode, the only option available is [1] *Enable Complete AMA*.

Activate the AMA function by pressing [Hand On] after selecting [1] *Enable Complete AMA* or [2] *Enable Reduced AMA*. After a normal sequence, the display reads: Press [OK] to finish AMA. After pressing [OK], the drive is ready for operation.

- For the best adaptation of the drive, run AMA on a cold motor.
- AMA cannot be performed while the motor is running.
- AMA cannot be performed on a motor with a bigger power rating than the drive, for example, when a 5.5 kW (7.4 hp) motor is connected to a 4 kW (5.4 hp) drive.

N O T I C E

Avoid generating external torque during AMA.

N O T I C E

If 1 of the settings in *parameter group 1-2* Motor Data* is changed, the advanced motor parameters, *parameter 1-30 Stator Resistance (Rs)* to *parameter 1-39 Motor Poles*, return to default setting.

N O T I C E

Perform a full AMA without filter only, while reduced AMA should be run with a filter.

4.3.4 1-3* Motor Data II

This parameter group comprises input data from the nameplate on the connected motor.

1-30 Stator Resistance (Rs)

Default value: Configuration dependent	Parameter type: Range	2-setup: All setups
Conversion index: -3	Data type: u_int32	Change during operation: False

Set the stator resistance value. Enter the value from a motor datasheet or perform an AMA on a cold motor.

Table 54: Range:

Min: 0.0 Ohm	Max: 9999.000 Ohm	Default value: Configuration dependent
--------------	-------------------	--

1-31 Rotor Resistance (Rr)

Default value: Configuration dependent	Parameter type: Range	2-setup: All setups
Conversion index: -3	Data type: u_int32	Change during operation: False

Enter the rotor resistance value. Obtain the value from a motor data sheet or by performing an AMA on a cold motor. The default setting is calculated by the drive from motor nameplate data.

Table 55: Range:

Min: 0	Max: 9999.000 Ohm	Default value: Configuration dependent
--------	-------------------	--

1-33 Stator Leakage Reactance (X1)

Default value: Configuration dependent	Parameter type: Range	2-setup: All setups
Conversion index: -3	Data type: u_int32	Change during operation: False

Set the stator leakage reactance value. Enter the value from a motor data sheet or perform an AMA on a cold motor. The default setting is calculated by the drive from motor nameplate data.

Table 56: Range:

Min: 0.0 Ohm	Max: 9999.000 Ohm	Default value: Configuration dependent
--------------	-------------------	--

1-35 Main Reactance (Xh)

Default value: Configuration dependent	Parameter type: Range	2-setup: All setups
Conversion index: -2	Data type: u_int32	Change during operation: False

Set the main reactance value. Enter the value from a motor data sheet or perform an AMA on a cold motor. The default setting is calculated by the drive from motor nameplate data.

Table 57: Range:

Min: 0.0 Ohm	Max: 9999.00 Ohm	Default value: Configuration dependent
--------------	------------------	--

1-37 d-axis Inductance (Ld)

Default value: Configuration dependent	Parameter type: Range	2-setup: All setups
Conversion index: -3	Data type: int32	Change during operation: False

Enter the value of the d-axis inductance. Obtain the value from the permanent magnet motor data sheet or perform an AMA on a cold motor.

Table 58: Range:

Min: 0.001 mH	Max: 65535 mH	Default value: Configuration dependent
---------------	---------------	--

1-38 q-axis Inductance (Lq)

Default value: Configuration dependent	Parameter type: Range	2-setup: All setups
Conversion index: -3	Data type: int32	Change during operation: False

Enter the value of the q-axis inductance. Obtain the value from the permanent magnet motor data sheet or perform an AMA on a cold motor.

Table 59: Range:

Min: 0.001 mH	Max: 65535 mH	Default value: Configuration dependent
---------------	---------------	--

1-39 Motor Poles

Default value: Configuration dependent	Parameter type: Range	2-setup: All setups
Conversion index: -	Data type: u_int8	Change during operation: False

Enter the number of motor poles. The motor pole value is always an even number, because it refers to the total pole number, not pairs of poles.

Table 60: Range:

Min: 2	Max: 100	Default value: Configuration dependent
--------	----------	--

4.3.5 1-4* Adv. Motor Data II

This parameter group comprises input data from the nameplate on the connected motor.

1-40 Back EMF at 1000 RPM

Default value: Configuration dependent	Parameter type: Range	2-setup: All setups
Conversion index: -	Data type: u_int16	Change during operation: False

Line-line RMS back EMF voltage at 1000 RPM.

Table 61: Range:

Min: 1 V	Max: 9000 V	Default value: Configuration dependent
----------	-------------	--

1-42 Motor Cable Length

Default value: 50 m	Parameter type: Range	2-setup: All setups
Conversion index: -	Data type: u_int8	Change during operation: False

Set the motor cable length during commissioning.

Table 62: Range:

Min: 0 m	Max: 100 m	Default value: 50 m
----------	------------	---------------------

1-43 Motor Cable Length Feet

Default value: 164 ft	Parameter type: Range	2-setup: All setups
Conversion index: -	Data type: u_int16	Change during operation: False

Set the motor cable length during commissioning.

Table 63: Range:

Min: 0 ft	Max: 328 ft	Default value: 164 ft
-----------	-------------	-----------------------

1-44 d-axis Inductance Sat. (LdSat)

Default value: Configuration dependent	Parameter type: Range	2-setup: All setups
Conversion index: -3	Data type: int32	Change during operation: False

This parameter corresponds to the inductance saturation of Ld. Ideally, this parameter has the same value as *parameter 1-37 d-axis Inductance (Ld)*. However, if the motor supplier provides an induction curve, enter the induction value here, which is 200% of the nominal current.

Table 64: Range:

Min: 0 mH	Max: 65535 mH	Default value: Configuration dependent
-----------	---------------	--

1-45 q-axis Inductance Sat. (LqSat)

Default value: Configuration dependent	Parameter type: Range	2-setup: All setups
Conversion index: -3	Data type: int32	Change during operation: False

This parameter corresponds to the inductance saturation of Lq. Ideally, this parameter has the same value as *parameter 1-38 q-axis Inductance (Lq)*. However, if the motor supplier provides an induction curve, enter the induction value here, which is 200% of the nominal current.

Table 65: Range:

Min: 0 mH	Max: 65535 mH	Default value: Configuration dependent
-----------	---------------	--

1-46 Position Detection Gain

Default value: 100%	Parameter type: Range	2-setup: All setups
Conversion index: -	Data type: u_int16	Change during operation: True

Adjust the amplitude of the test pulse during position detection at start. Adjust this parameter to improve the position measurement.

Table 66: Range:

Min: 20%	Max: 200%	Default value: 100%
----------	-----------	---------------------

1-48 Current at Min Inductance for d-axis

Default value: 100%	Parameter type: Range	2-setup: All setups
Conversion index: -	Data type: int16	Change during operation: False

Use this parameter to set the inductance saturation point.

Table 67: Range:

Min: 20%	Max: 200%	Default value: 100%
----------	-----------	---------------------

1-49 Current at Min Inductance for q-axis

Default value: 100%	Parameter type: Range	2-setup: All setups
Conversion index: -	Data type: u_int16	Change during operation: False

Specify the saturation curve of the q-axis inductance values. The q-axis inductance value is linearly approximated to parameters *parameter 1-38 q-axis Inductance (Lq)* and *parameter 1-45 q-axis Inductance Sat. (LqSat)*.

Table 68: Range:

Min: 20%	Max: 200%	Default value: 100%
----------	-----------	---------------------

4.3.6 1-5* Load Indep. Setting

Parameters for load-independent motor settings.

1-50 Motor Magnetisation at Zero Speed

Default value: 100 %	Parameter type: Range	2-setup: All setups
Conversion index: -	Data type: u_int16	Change during operation: True

Use this parameter along with *parameter 1-52 Min Speed Normal Magnetising [Hz]* to obtain a different thermal load on the motor when running at low speed. Enter a value that is a percentage of the rated magnetizing current. If the setting is too low, the torque on the motor shaft may be reduced.

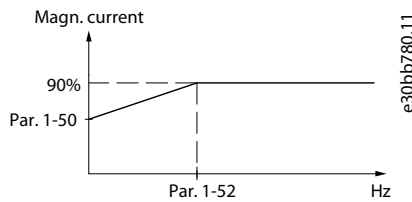

Illustration 7: Motor Magnetization

Table 69: Range:

Min: 0%	Max: 300%	Default value: 100%
---------	-----------	---------------------

1-52 Min Speed Normal Magnetising [Hz]

Default value: 1 Hz	Parameter type: Range	2-setup: All setups
Conversion index: -1	Data type: u_int16	Change during operation: True

Set the required frequency for normal magnetizing current. Use this parameter along with *parameter 1-50 Motor Magnetisation at Zero Speed*.

Table 70: Range:

Min: 0.1 Hz	Max: 10.0 Hz	Default value: 1 Hz
-------------	--------------	---------------------

1-55 U/f Characteristic - U

Default value: Configuration dependent	Parameter type: Range	2-setup: All setups
Conversion index: -	Data type: u_int16	Change during operation: True

Enter voltage at each frequency point to form a U/f characteristic matching the motor. Frequency points are defined in *parameter 1-56 U/f Characteristic - F*.

Table 71: Range:

Min: 0 V	Max: 999 V	Default value: Configuration dependent
----------	------------	--

1-56 U/f Characteristic - F

Default value: Configuration dependent	Parameter type: Range	2-setup: All setups
Conversion index: -	Data type: u_int16	Change during operation: True

Enter frequency points to form a U/f characteristic matching the motor. Voltage at each point is defined in *parameter 1-55 U/f Characteristic - U*.

Make a U/f characteristic based on 6 definable voltages and frequencies, see the following illustration. Simplify U/f characteristics by merging 2 or more points (voltages and frequencies). Set the points at equal values.

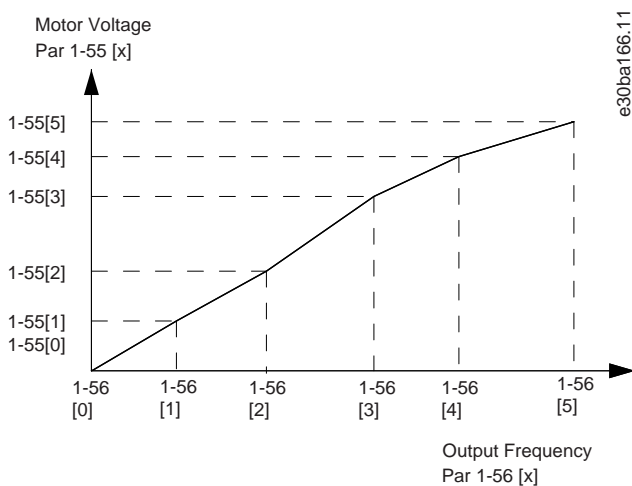

Illustration 8: U/f Characteristic

Table 72: Range:

Min: 0 Hz	Max: 400.0 Hz	Default value: Configuration dependent
-----------	---------------	--

4.3.7 1-6* Load Depen. Setting

Parameters for adjusting the load-dependent motor settings.

1-62 Slip Compensation

Default value: 0%	Parameter type: Range	2-setup: All setups
Conversion index: -	Data type: int16	Change during operation: True

Enter the % value for slip compensation to compensate for tolerances in the value of $n_{M,N}$. Slip compensation is calculated automatically, which is based on the nominal motor speed $n_{M,N}$.

Table 73: Range:

Min: -400%	Max: 400%	Default value: 0%
------------	-----------	-------------------

1-63 Slip Compensation Time Constant

Default value: 0.10 s	Parameter type: Range	2-setup: All setups
Conversion index: -2	Data type: u_int16	Change during operation: True

Enter the slip compensation reaction speed. A high value results in slow reaction, and a low value results in quick reaction. If low-frequency resonance problems arise, use a longer time setting.

Table 74: Range:

Min: 0.05 s	Max: 5.00 s	Default value: 0.10 s
-------------	-------------	-----------------------

1-64 Resonance Dampening

Default value: 100%	Parameter type: Range	2-setup: All setups
Conversion index: -	Data type: u_int16	Change during operation: True

Enter the resonance damping value. Set *parameter 1-64 Resonance Dampening* and *parameter 1-65 Resonance Dampening Time Constant* to help eliminate high-frequency resonance problems. To reduce resonance oscillation, increase the value of *parameter 1-64 Resonance Dampening*.

Table 75: Range:

Min: 0%	Max: 500%	Default value: 100%
---------	-----------	---------------------

1-65 Resonance Dampening Time Constant

Default value: 0.005 s	Parameter type: Range	2-setup: All setups
Conversion index: -3	Data type: u_int16	Change during operation: True

Set *parameter 1-64 Resonance Dampening* and *parameter 1-65 Resonance Dampening Time Constant* to help eliminate high-frequency resonance problems. Enter the time constant that provides the best dampening.

Table 76: Range:

Min: 0.001 s	Max: 0.050 s	Default value: 0.005 s
--------------	--------------	------------------------

1-66 Min. Current at Low Speed

Default value: 50%	Parameter type: Range	2-setup: All setups
Conversion index: -	Data type: u_int16	Change during operation: True

Applies to PM motors only. Increasing the minimum current improves motor torque at low speed, but also reduces efficiency.

Table 77: Range:

Min: 0%	Max: 120%	Default value: 50%
---------	-----------	--------------------

4.3.8 1-7* Start Adjustments

Parameters for setting special motor start features.

1-70 Start Mode

Default value: [1] Parking	Parameter type: Option	2-setup: All setups
Conversion index: -	Data type: u_int8	Change during operation: True

Use this parameter to select the PM motor start mode which is to initialize the VVC⁺ control core for previously free running PM motors. This parameter is active for PM motors in VVC⁺ mode only if the motor is stopped (or running at low speed).

Table 78: Option:

[0]	Rotor Detection	The rotor detection function estimates the electrical angle of the rotor and uses the angle as a starting point. This option is the standard selection for automation drive applications. If the flying start function detects that the motor is running at low speed or is stopped, the drive can detect the rotor position (the angle). The drive then starts the motor from that angle.
[1]	Parking	The parking function applies DC current across the stator winding and rotates the rotor to electrical zero position. This function is typically selected for HVAC applications. If the flying start function detects that motor is running at low speed or is stopped, the drive sends out a DC current to park the motor at an angle. The drive then starts the motor from that angle.
[3]	Rotor Last Position	Rotor last position takes the advantage of the last position of rotor at stop to give a very quick start. It records the last position of rotor at stop, DC brake cut in speed function can be used to ensure the rotor is accurate and stably stopping at the last position. For start just after power up and coast, flystart or rotor detection must be performed according to the rotor speed.

1-71 Start Delay

Default value: 0 s	Parameter type: Range	2-setup: All setups
Conversion index: -1	Data type: u_int8	Change during operation: True

This parameter enables a delay of the starting time. The drive begins with the start function selected in *parameter 1-72 Start Function*. Set the start delay time until acceleration is to begin.

Table 79: Range:

Min: 0 s	Max: 25.5 s	Default value: 0 s
----------	-------------	--------------------

1-72 Start Function

Default value: [2] Coast/delay time	Parameter type: Option	2-setup: All setups
Conversion index: -	Data type: u_int8	Change during operation: True

Select the start function during start delay when a non-zero value is set in *parameter 1-71 Start Delay*.

Table 80: Option:

[0]	DC Hold/delay time	The motor is energized with <i>parameter 2-00 DC Hold/Motor Preheat Current</i> during start delay time.
[2]	Coast/delay time	A temperature-dependent resistor is coasted during start delay time (drive off).

1-73 Flying Start

Default value: -	Parameter type: Option	2-setup: All setups
Conversion index: -	Data type: u_int8	Change during operation: True

This function makes it possible to catch a motor that is spinning freely due to a mains drop-out. Flying start searches in clockwise direction only. If not successful, a DC brake is activated. If PM-enabled options are selected, parking is carried out if the speed is below 2.5–5% of nominal speed, in the time set in *parameter 2-07 Parking Time*.

If the speed estimate comes out below 2.5–5% of nominal speed, the parking function is engaged (see *parameter 2-06 Parking Current* and *parameter 2-07 Parking Time*). Otherwise, the drive catches the motor at that speed and resumes normal operation.

The flying start function used for PM motors is based on an initial speed estimation. The speed is always estimated as the 1st thing after an active start signal is given.

Current limitations of the flying start principle used for PM motors:

- The speed range is up to 100% nominal speed or the field weakening speed (whichever is lowest).
- For high inertia applications (that is, where the load inertia is more than 30 times larger than the motor inertia).

Table 81: Option:

[0]	Disabled	Disable the function.
[1]	Enabled	Enable the function.

4.3.9 1-8* Stop Adjustments

Parameters for configuring special motor stop features.

1-80 Function at Stop

Default value: [0] Coast	Parameter type: Option	2-setup: All setups
Conversion index: -	Data type: u_int8	Change during operation: True

Select this function after a stop command or after the speed is ramped down to the settings in *parameter 1-82 Min Speed for Function at Stop [Hz]*.

Table 82: Option:

[0]	Coast	Leave the motor in free mode.
[1]	DC hold / Motor Preheat	Energize the motor with a DC hold current (see <i>parameter 2-00 DC Hold/Motor Preheat Current</i>).

1-82 Min Speed for Function at Stop [Hz]

Default value: 0 Hz	Parameter type: Range	2-setup: All setups
Conversion index: -1	Data type: u_int16	Change during operation: True

Set the output frequency at which to activate *parameter 1-80 Function at Stop*.

Table 83: Range:

Min: 0 Hz	Max: 500.0 Hz	Default value: 0 Hz
-----------	---------------	---------------------

1-88 AC Brake Gain

Default value: 1.4	Parameter type: Range	2-setup: All setups
Conversion index: -1	Data type: u_int16	Change during operation: True

This parameter is used to set AC brake power capability (set ramp-down time when inertia is constant). In the condition that the DC-link voltage is not higher than DC-link voltage warning value, the generator torque can be adjusted with this parameter.

Table 84: Range:

Min: 1.0	Max: 2.0	Default value: 1.4
----------	----------	--------------------

4.3.10 1-9* Motor Temperature

Parameters for configuring the temperature protection features for the motor.

1-90 Motor Thermal Protection

Default value: [4] ETR trip 1	Parameter type: Option	2-setup: All setups
Conversion index: -	Data type: u_int8	Change during operation: True

Using ETR (electronic thermal relay), the motor temperature is calculated based on frequency, current, and time. Danfoss recommends using the ETR function, if a thermistor is not present. The functionality is the same for asynchronous motors and PM motors.

N O T I C E

ETR calculation is based on motor data from *parameter group 1-2* Motor Data*.

Table 85: Option:

[0]	No protection	Disable temperature monitoring.
[1]	Thermistor warning	A thermistor gives a warning if the upper limit of motor temperature range is exceeded.
[2]	Thermistor trip	If the upper limit of motor temperature range is exceeded, a thermistor gives an alarm and makes the drive trip.
[3]	ETR warning 1	If the calculated upper limit of the motor temperature range is exceeded, a warning occurs.
[4]	ETR trip 1	Start motor thermal calculation based on actual load and time as well as motor frequency only when the motor current is above 110% of the nominal motor current.
[22]	ETR Trip – Extended Detection	Start motor thermal calculation based on actual load and time as well as motor frequency when the motor current is above 110% of the nominal motor current. Another situation is to start motor thermal calculation when the motor current is less than 110% of the nominal motor current and trigger current limit.

1-93 Thermistor Source

Default value: [0] None	Parameter type: Option	2-setup: All setups
Conversion index: -	Data type: u_int8	Change during operation: False

N O T I C E

Set the digital input to [0] PNP - Active at 24 V in *parameter 5-03 Digital Input 29 Mode*.

Select the input at which the thermistor (PTC sensor) should be connected. When using an analog input, the same analog cannot be used as a reference in *parameter 3-15 Reference Resource 1* to *parameter 3-17 Reference Resource 3*, *parameter 20-00 Feedback 1 Source*, *parameter 20-03 Feedback 2 Source*, *parameter 24-06 Fire Mode Reference Source*, and *parameter 24-07 Fire Mode Feedback Source*.

Table 86: Option:

[0]	None	Do not set thermistor source.
[1]	Analog input AI53	Use analog input 53 as thermistor source.
[6]	Digital input 29	Use digital input 29 as thermistor source.

4.4 Parameter Group 2-** Brakes

4.4.1 2-0* DC-Brake

Parameters for configuring the DC brake and DC hold functions.

2-00 DC Hold/Motor Preheat Current

Default value: 50%	Parameter type: Range	2-setup: All setups
Conversion index: -	Data type: u_int16	Change during operation: True

NOTICE

MOTOR OVERHEATING

The maximum value depends on the rated motor current.

- To avoid motor damage caused by overheating, do not run at 100% for too long.

Set holding current as a percentage of the rated motor current $I_{M,N}$ in *parameter 1-24 Motor Current*. *Parameter 2-00 DC Hold/Motor Preheat Current* holds the motor function (holding torque) or pre-heats the motor. This parameter is active if DC hold is selected in *parameter 1-72 Start Function [0] DC Hold/delay time* or *parameter 1-80 Function at Stop [1] DC hold/Motor Preheat*.

Table 87: Range:

Min: 0%	Max: 160%	Default value: 50%
---------	-----------	--------------------

2-01 DC Brake Current

Default value: 50%	Parameter type: Range	2-setup: All setups
Conversion index: -	Data type: u_int16	Change during operation: True

NOTICE

MOTOR OVERHEATING

The maximum value depends on the rated motor current.

- To avoid motor damage caused by overheating, do not run at 100% for too long.

Set current as % of rated motor current, *parameter 1-24 Motor Current*. When speed is below the limit set in *parameter 2-04 DC Brake Cut In Speed*, or when the DC-brake inverse function is active (in *parameter group 5-1* Digital Inputs* set to [5] DC-brake inverse; or via the serial port), a DC brake current is applied on a stop command. See *parameter 2-02 DC Braking Time* for duration.

Table 88: Range:

Min: 0%	Max: 150%	Default value: 50%
---------	-----------	--------------------

2-02 DC Braking Time

Default value: 10 s	Parameter type: Range	2-setup: All setups
Conversion index: -1	Data type: u_int16	Change during operation: True

Set the duration of the DC-brake current set in *parameter 2-01 DC Brake Current*, once activated.

Table 89: Range:

Min: 0 s	Max: 60 s	Default value: 10 s
----------	-----------	---------------------

2-04 DC Brake Cut In Speed

Default value: 0 Hz	Parameter type: Range	2-setup: All setups
Conversion index: -1	Data type: u_int16	Change during operation: True

This parameter is for setting the DC-brake cut-in speed at which *parameter 2-01 DC Brake Current* is to be active with a stop command.

Table 90: Range:

Min: 0 Hz	Max: 500 Hz	Default value: 0 Hz
-----------	-------------	---------------------

2-06 Parking Current

Default value: 100%	Parameter type: Range	2-setup: All setups
Conversion index: -	Data type: u_int16	Change during operation: True

Set current as percentage of rated motor current, *parameter 1-24 Motor Current*. Active with *parameter 1-73 Flying Start*. The parking current is active during the time period set in *parameter 2-07 Parking Time*.

N O T I C E

Parameter 2-06 Parking Current is only active when 1 of the PM motor construction options is selected in *parameter 1-10 Motor Construction*.

Table 91: Range:

Min: 0%	Max: 150%	Default value: 100%
---------	-----------	---------------------

2-07 Parking Time

Default value: 3 s	Parameter type: Range	2-setup: All setups
Conversion index: -1	Data type: u_int16	Change during operation: True

Set the duration of the parking current time set in *parameter 2-06 Parking Current*. Active with *parameter 1-73 Flying Start*.

N O T I C E

Parameter 2-07 Parking Time is only active when options of *parameter 1-10 Motor Construction* are set to enable PM motors.

Table 92: Range:

Min: 0.1 s	Max: 60 s	Default value: 3 s
------------	-----------	--------------------

4.4.2 2-1* Brake Energy Function

Parameter group for selecting dynamic brake parameters.

2-10 Brake Function

Default value: [0] Off	Parameter type: Option	2-setup: All setups
Conversion index: -	Data type: u_int8	Change during operation: True

Table 93: Option:

[0]	Off	The brake resistor is not active.
[2]	AC brake	AC brake is active.

2-16 AC Brake, Max current

Default value: 100%	Parameter type: Range	2-setup: All setups
Conversion index: -	Data type: u_int16	Change during operation: True

Enter the maximum permissible current when using the AC brake to avoid overheating motor windings.

Table 94: Range:

Min: 0%	Max: 160%	Default value: 100%
---------	-----------	---------------------

2-17 Over-voltage Control

Default value: [2] Enabled	Parameter type: Option	2-setup: All setups
Conversion index: -	Data type: u_int8	Change during operation: True

Select whether to enable OVC during ramp down, which reduces the risk of drive trip due to overvoltage on the DC link caused by generative power from load.

Table 95: Option:

[0]	Disabled	No OVC required.
[1]	Enabled (not at stop)	Activates OVC when the drive is not in the stop state.
[2]	Enabled	Activates OVC.
<div style="background-color: #cccccc; padding: 5px; margin: 10px auto; width: 80%;"> <p style="margin: 0;">NOTICE</p> <p style="margin: 0;">The ramp time is automatically adjusted to avoid tripping of the drive.</p> </div>		

2-19 Over-voltage Gain

Default value: 100%	Parameter type: Range	2-setup: All setups
Conversion index: -	Data type: u_int16	Change during operation: True

This parameter enables the user to fine tune the overvoltage gain for *parameter 2-17 Over-voltage Control*. It is not necessary to change this parameter for normal applications.

Table 96: Range:

Min: 1%	Max: 500%	Default value: 100%
---------	-----------	---------------------

4.5 Parameter Group 3-** Reference/Ramps

4.5.1 3-0* Reference Limits

Parameters for setting the reference unit, limits, and ranges. Also see *parameter group 20-0* Feedback* for information on settings in closed loop.

3-02 Minimum Reference

Default value: 0	Parameter type: Range	2-setup: All setups
Conversion index: -3	Data type: int32	Change during operation: True

The minimum reference is the lowest value obtainable by summing all references.

Table 97: Range:

Min: -4999	Max: 4999	Default value: 0
------------	-----------	------------------

3-03 Maximum Reference

Default value: Configuration dependent	Parameter type: Range	2-setup: All setups
Conversion index: -3	Data type: int32	Change during operation: True

The maximum reference is the highest value obtainable by summing all references. The maximum reference unit matches the selection of configuration in *parameter 1-00 Configuration Mode*.

Table 98: Range:

Min: -4999.0	Max: 4999	Default value: Configuration dependent
--------------	-----------	--

4.5.2 3-1* References

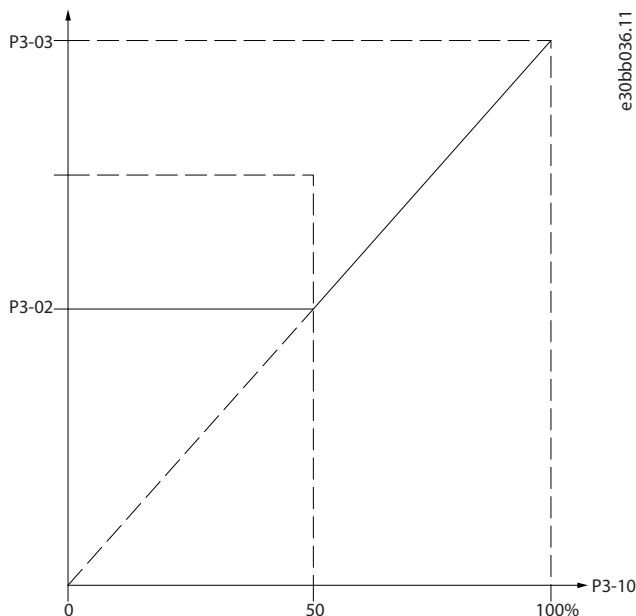

Illustration 9: References

3-10 Preset Reference

Default value: 0%	Parameter type: Range	2-setup: All setups
Conversion index: -2	Data type: int16 [8]	Change during operation: True

Enter up to 8 different preset references (0–7) in this parameter, using array programming. For selecting dedicated references, select preset reference bit 0/1/2 [16], [17], or [18] for the corresponding digital inputs in *parameter group 5-1* Digital Inputs*.

Table 99: Range:

Min: -100%	Max: +100%	Default value: 0%
------------	------------	-------------------

3-11 Jog Speed [Hz]

Default value: 5 Hz	Parameter type: Range	2-setup: All setups
Conversion index: -1	Data type: u_int16	Change during operation: True

The jog speed is a fixed output speed at which the drive runs when the jog function is activated. See also *parameter 3-80 Jog Ramp Time*.

Table 100: Range:

Min: 0 Hz	Max: 500.0 Hz	Default value: 5 Hz
-----------	---------------	---------------------

3-14 Preset Relative Reference

Default value: 0%	Parameter type: Range	2-setup: All setups
Conversion index: -2	Data type: int16	Change during operation: True

Define the fixed value in % to be added to the variable value defined in *parameter 3-18 Relative Scaling Reference Resource*. The sum of fixed and variable values (labeled Y in the following illustration) is multiplied by actual reference (labeled X in the following illustration). This product is added to actual reference:

$$X + X \times \frac{Y}{100}$$

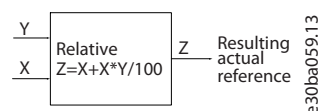

Illustration 10: Preset Relative Reference

Table 101: Range:

Min: -100%	Max: 100%	Default value: 0%
------------	-----------	-------------------

3-15 Reference 1 Source

Default value: [1] Analog Input 53	Parameter type: Option	2-setup: All setups
Conversion index: -	Data type: u_int8	Change during operation: True

Select the input to be used for the 1st reference signal. *Parameter 3-15 Reference 1 Source, parameter 3-16 Reference 2 Source, and parameter 3-17 Reference 3 Source* define up to 3 different reference signals. The sum of these reference signals defines the actual reference.

Table 102: Option:

[0]	No function
[1]	Analog Input 53
[2]	Analog Input 54
[7]	Pulse input 29
[11]	Local bus reference

3-16 Reference 2 Source

Default value: [2] Analog Input 54	Parameter type: Option	2-setup: All setups
Conversion index: -	Data type: u_int8	Change during operation: True

Select the input to be used for the 2nd reference signal. *Parameter 3-15 Reference 1 Source, parameter 3-16 Reference 2 Source, and parameter 3-17 Reference 3 Source* define up to 3 different reference signals. The sum of these reference signals defines the actual reference.

Table 103: Option:

[0]	No function
[1]	Analog Input 53
[2]	Analog Input 54
[7]	Pulse input 29
[11]	Local bus reference

3-17 Reference 3 Source

Default value: [11] Local bus reference	Parameter type: Option	2-setup: All setups
Conversion index: -	Data type: u_int8	Change during operation: True

Select the input to be used for the 3rd reference signal. *Parameter 3-15 Reference 1 Source*, *parameter 3-16 Reference 2 Source*, and *parameter 3-17 Reference 3 Source* define up to 3 different reference signals. The sum of these reference signals defines the actual reference.

Table 104: Option:

[0]	No function
[1]	Analog Input 53
[2]	Analog Input 54
[7]	Pulse input 29
[11]	Local bus reference

4.5.3 3-4* Ramp 1

Configure the ramp time parameters for each of the 2 ramps (*parameter group 3-4* Ramp 1* and *parameter group 3-5* Ramp 2*). The ramp time is preset to the minimum value of 10 ms for all power sizes.

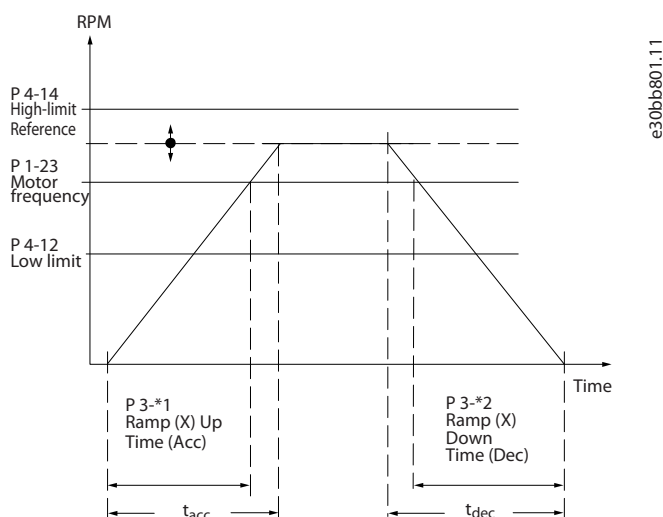

Illustration 11: Ramps

3-41 Ramp 1 Ramp Up Time

Default value: Configuration dependent	Parameter type: Range	2-setup: All setups
Conversion index: -2	Data type: u_int32	Change during operation: True

Enter acceleration time from 0 Hz to *parameter 1-23 Motor Frequency* if asynchronous motor is selected. Enter acceleration time from 0 RPM to *parameter 1-25 Motor Nominal Speed* if PM motor is selected. Select a ramp-up time such that the output current does not exceed the current limit in *parameter 4-18 Current Limit* during ramping. See ramp-down time in *parameter 3-42 Ramp 1 Ramp Down Time*.

Table 105: Range:

Min: 0.01 s	Max: 3600 s	Default value: Configuration dependent
-------------	-------------	--

3-42 Ramp 1 Ramp Down Time

Default value: Configuration dependent	Parameter type: Range	2-setup: All setups
Conversion index: -2	Data type: u_int32	Change during operation: True

If asynchronous motor is selected, enter deceleration time from *parameter 1-23 Motor Frequency* to 0 Hz. If PM motor is selected, enter deceleration time from *parameter 1-25 Motor Nominal Speed* to 0 RPM. Select a ramp-down time to avoid tripping on overvoltage in the DC-link.

Table 106: Range:

Min: 0.01 s	Max: 3600 s	Default value: Configuration dependent
-------------	-------------	--

4.5.4 3-5* Ramp 2

This parameter group configures ramp 2 parameters.

3-51 Ramp 2 Ramp Up Time

Default value: Configuration dependent	Parameter type: Range	2-setup: All setups
Conversion index: -2	Data type: u_int32	Change during operation: True

If asynchronous motor is selected, enter acceleration time from 0 Hz to *parameter 1-23 Motor Frequency*. If PM motor is selected, enter acceleration time from 0 RPM to *parameter 1-25 Motor Nominal Speed*. Select a ramp-up time such that the output current does not exceed the current limit in *parameter 4-18 Current Limit* during ramping up.

Table 107: Range:

Min: 0.01 s	Max: 3600 s	Default value: Configuration dependent
-------------	-------------	--

3-52 Ramp 2 Ramp Down Time

Default value: Configuration dependent	Parameter type: Range	2-setup: All setups
Conversion index: -2	Data type: u_int32	Change during operation: True

Enter deceleration time from *parameter 1-25 Motor Nominal Speed* to 0 RPM. Select a ramp-down time such that the output current does not exceed the current limit in *parameter 4-18 Current Limit* during ramping down.

Table 108: Range:

Min: 0.01 s	Max: 3600 s	Default value: Configuration dependent
-------------	-------------	--

4.5.5 3-8* Other Ramps

3-80 Jog Ramp Time

Default value: Configuration dependent	Parameter type: Range	2-setup: All setups
Conversion index: -2	Data type: u_int32	Change during operation: True

Enter the jog ramp time, which is the acceleration/deceleration time between 0 Hz to *parameter 1-23 Motor Frequency*. Ensure that the resulting output current required for the given jog ramp time does not exceed the current limit in *parameter 4-18 Current Limit*. The jog ramp time starts after activation of a jog signal via the control panel, a selected digital input, or the serial communication port.

Table 109: Range:

Min: 0.01 s	Max: 3600 s	Default value: Configuration dependent
-------------	-------------	--

3-81 Quick Stop Ramp Time

Default value: Configuration dependent	Parameter type: Range	2-setup: 1 setup
Conversion index: -2	Data type: u_int32	Change during operation: True

Enter the quick stop ramp time from the *parameter 1-23 Motor Frequency* to 0 Hz. During ramping, no overvoltage may occur in the inverter, nor may the generated current exceed the limit in *parameter 4-18 Current Limit*. Quick stop is activated with a signal on a selected digital input or via the serial communication port.

Table 110: Range:

Min: 0.01 s	Max: 3600 s	Default value: Configuration dependent
-------------	-------------	--

4.6 Parameter Group 4-** Limits/Warnings

4.6.1 4-1* Motor Limits

Define current and speed limits for the motor, and the reaction of the drive when the limits are exceeded.

4-10 Motor Speed Direction

Default value: [2] Both directions	Parameter type: Option	2-setup: All setups
Conversion index: -	Data type: u_int8	Change during operation: False

Select the motor speed direction(s) required. Use this parameter to prevent unwanted reversing.

Table 111: Option:

[0]	Clockwise	<div style="background-color: #cccccc; padding: 5px; margin-bottom: 5px;">NOTICE</div> <p>The setting in <i>parameter 4-10 Motor Speed Direction</i> has impact on <i>parameter 1-73 Flying Start</i>.</p> <p>Only operation in clockwise direction is allowed.</p>
[2]	Both directions	

4-12 Motor Speed Low Limit [Hz]

Default value: 0 Hz	Parameter type: Range	2-setup: All setups
Conversion index: -1	Data type: u_int16	Change during operation: True

Enter the minimum limit for motor speed. The motor speed low limit can be set to correspond to the minimum output frequency of the motor shaft. The speed low limit must not exceed the setting in *parameter 4-14 Motor Speed High Limit [Hz]*.

Table 112: Range:

Min: 0 Hz	Max: 400.0 Hz	Default value: 0 Hz
-----------	---------------	---------------------

4-14 Motor Speed High Limit [Hz]

Default value: 100 Hz	Parameter type: Range	2-setup: All setups
Conversion index: -1	Data type: u_int16	Change during operation: True

Enter the maximum limit for motor speed. It can be set to match the recommended maximum motor speed. The motor speed high limit must exceed the value in *parameter 4-12 Motor Speed Low Limit [Hz]*. Motor speed high limit cannot be set higher than *parameter 4-19 Max Output Frequency*.

Table 113: Range:

Min: 0.1 Hz	Max: 400.0 Hz	Default value: 100 Hz
-------------	---------------	-----------------------

4-18 Current Limit

Default value: 110%	Parameter type: Range	2-setup: All setups
Conversion index: -	Data type: u_int16	Change during operation: True

Enter the current limit for motor and generator operation. *Parameter 4-18 Current Limit* will be changed automatically if nominal motor current (*parameter 1-24 Motor Current*) is updated.

Table 114: Range:

Min: 0%	Max: 1000%	Default value: 110%
---------	------------	---------------------

4-19 Max Output Frequency

Default value: 100.0 Hz	Parameter type: Range	2-setup: All setups
Conversion index: -1	Data type: u_int16	Change during operation: False

Enter the maximum output frequency, which defines the absolute limit on the drive output frequency for improved safety in applications where unintended overspeeding must be avoided. This absolute limit applies to all configurations and is independent of the setting in *parameter 1-00 Configuration Mode*.

When *parameter 1-10 Motor Construction* is set to 1 of the options enabling PM motor construction, the maximum limit of *parameter 4-19 Max Output Frequency* might be limited by the setting of *parameter 1-40 Back EMF at 1000 RPM* to avoid a too high Back EMF, which can damage the drive. If *parameter 4-19 Max Output Frequency* is set lower than *parameter 4-14 Motor Speed High Limit [Hz]*, the value of *parameter 4-14 Motor Speed High Limit [Hz]* is adjusted to the same value as *parameter 4-19 Max Output Frequency* automatically.

Table 115: Range:

Min: 0 Hz	Max: 400 Hz	Default value: 100.0 Hz
-----------	-------------	-------------------------

4.6.2 4-4* Adjustable Warnings 2

4-40 Warning Freq. Low

Default value: 0 Hz	Parameter type: Range	2-setup: All setups
Conversion index: -1	Data type: u_int16	Change during operation: True

Use this parameter to set a lower limit for the frequency range. When the motor speed drops below this limit, the display reads *SPEED LOW*. Warning bit 10 is set in *parameter 16-94 Ext. Status Word*. The output relay or the digital output can be configured to indicate this warning. The LCP warning indicator light is not turned on when this parameter set limit is reached.

Table 116: Range:

Min: 0 Hz	Max: 500 Hz	Default value: 0 Hz
-----------	-------------	---------------------

4-41 Warning Freq. High

Default value: 100 Hz	Parameter type: Range	2-setup: All setups
Conversion index: -1	Data type: u_int16	Change during operation: True

Use this parameter to set a higher limit for the frequency range. When the motor speed exceeds this limit, the display reads *SPEED HIGH*. Warning bit 9 is set in *parameter 16-94 Ext. Status Word*. The output relay or the digital output can be configured to indicate this warning. The LCP warning indicator light is not turned on when this parameter set limit is reached.

Table 117: Range:

Min: 0 Hz	Max: 500 Hz	Default value: 100 Hz
-----------	-------------	-----------------------

4.6.3 4-5* Adj. Warnings

Define adjustable warning limits for current. Warnings are shown on the display, programmed output, or fieldbus.

4-50 Warning Current Low

Default value: 0 A	Parameter type: Range	2-setup: All setups
Conversion index: -2	Data type: u_int32	Change during operation: True

Enter the I_{LOW} value. When the motor current drops below this limit, a bit in the status word is set. This value can also be programmed to produce a signal on the digital output or the relay output.

Table 118: Range:

Min: 0 A	Max: 500 A	Default value: 0 A
----------	------------	--------------------

4-51 Warning Current High

Default value: Configuration dependent	Parameter type: Range	2-setup: All setups
Conversion index: -2	Data type: u_int32	Change during operation: True

Enter the I_{HIGH} value. When the motor current exceeds this limit, a bit in the status word is set. This value can also be programmed to produce a signal on the digital output or the relay output.

Table 119: Range:

Min: 0.0 A	Max: 500.00 A	Default value: Configuration dependent
------------	---------------	--

4-54 Warning Reference Low

Default value: -4999	Parameter type: Range	2-setup: All setups
Conversion index: -3	Data type: int32	Change during operation: True

Enter the lower reference limit. When the actual reference drops below this limit, the display indicates Ref_{LOW} . Warning bit 20 is set in *parameter 16-94 Ext. Status Word*. The output relay or the digital output can be configured to indicate this warning. The LCP warning indicator light is not turned on when this parameter set limit is reached.

Table 120: Range:

Min: -4999	Max: 4999	Default value: -4999
------------	-----------	----------------------

4-55 Warning Reference High

Default value: 4999	Parameter type: Range	2-setup: All setups
Conversion index: -3	Data type: int32	Change during operation: True

Use this parameter to set a higher limit for the reference range. When the actual reference exceeds this limit, the display reads Reference High. Warning bit 19 is set in *parameter 16-94 Ext. Status Word*. The output relay or the digital output can be configured to indicate this warning. The LCP warning indicator light is not turned on when this parameter set limit is reached.

Table 121: Range:

Min: -4999	Max: 4999	Default value: 4999
------------	-----------	---------------------

4-56 Warning Feedback Low

Default value: -4999.000	Parameter type: Range	2-setup: All setups
Conversion index: -3	Data type: int32	Change during operation: True

Use this parameter to set a lower limit for the feedback range. When the feedback drops below this limit, the display reads *Feedback Low*. Warning bit 6 is set in *parameter 16-94 Ext. Status Word*. The output relay or digital output can be configured to indicate this warning. The LCP warning indicator light is not turned on when this parameter set limit is reached.

Table 122: Range:

Min: -4999.000	Max: 4999.000	Default value: -4999.000
----------------	---------------	--------------------------

4-57 Warning Feedback High

Default value: 4999.000	Parameter type: Range	2-setup: All setups
Conversion index: -3	Data type: int32	Change during operation: True

Use this parameter to set a higher limit for the feedback range. When the feedback exceeds this limit, the display reads *Feedback High*. Warning bit 5 is set in *parameter 16-94 Ext. Status Word*. The output relay or digital output can be configured to indicate this warning. The LCP warning indicator light is not turned on when this parameter set limit is reached.

Table 123: Range:

Min: -4999.000	Max: 4999.000	Default value: 4999.000
----------------	---------------	-------------------------

4-58 Missing Motor Phase Function

Default value: [1] Trip 10 s	Parameter type: Option	2-setup: All setups
Conversion index: -	Data type: u_int8	Change during operation: False

Table 124: Option:

[0]	Off	No alarm is shown if a missing motor phase occurs.
[1]	Trip 10 s	The drive performs a scans for 10 s to detect a missing motor phase. When a missing motor phase is detected, the drive trips.

4.6.4 4-6* Speed Bypass

Define the speed bypass areas for the ramps. 3 frequency ranges can be avoided.

4-61 Bypass Speed From [Hz]

Default value: 0 Hz	Parameter type: Range	2-setup: All setups
Conversion index: -1	Data type: u_int16	Change during operation: True

Enter the lower limits of the speeds to be avoided. Some systems call for avoiding certain output speeds due to resonance problems in the system.

Table 125: Range:

Min: 0 Hz	Max: 500 Hz	Default value: 0 Hz
-----------	-------------	---------------------

4-63 Bypass Speed To [Hz]

Default value: 0 Hz	Parameter type: Range	2-setup: All setups
Conversion index: -1	Data type: u_int16	Change during operation: True

Some systems call for avoiding certain output speeds due to resonance problems in the system. Enter the upper limits of the speeds to be avoided.

Table 126: Range:

Min: 0 Hz	Max: 500 Hz	Default value: 0 Hz
-----------	-------------	---------------------

4-64 Semi-Auto Bypass Set-up

Default value: [0] Off	Parameter type: Option	2-setup: 1 setup
Conversion index: -	Data type: u_int8	Change during operation: True

Use the semi-automatic bypass speed setup to facilitate the programming of the frequencies to be skipped due to resonances in the system.

Table 127: Option:

[0]	Off	This function is turned off.
[1]	Enable	If this option is selected, speed ranges are automatically swept to identify bands of resonances.

4.6.4.1 Setting Up Semi-Automatic Bypass Speed

Procedure

1. Stop the motor.

NOTICE

Adjust the ramp times in *parameter 3-41 Ramp 1 Ramp Up Time* and *parameter 3-42 Ramp 1 Ramp Down Time*.

2. Select [1] Enabled in *parameter 4-64 Semi-Auto Bypass Set-up*.
3. Press [Hand On] to start the search for frequency bands causing resonances. The motor ramps up according to the ramp set.

NOTICE

Terminal 27 digital input *parameter 5-12 Terminal 27 Digital Input* has [2] Coast inverse as default setting. If there is no 24 V to terminal 27, [Hand On] does not start the motor. If so, connect terminal 12 to terminal 27.

4. When sweeping through a resonance band, press [OK] on the LCP when leaving the band. The actual frequency is stored as the 1st element in *parameter 4-63 Bypass Speed To [Hz]* (array). Repeat this procedure for each resonance band identified at the ramp-up (maximum of 3 can be adjusted).
5. When maximum speed has been reached, the motor automatically begins to ramp down. Repeat this procedure when speed is leaving the resonance bands during the deceleration. The actual frequencies registered when pressing [OK] are stored in *parameter 4-61 Bypass Speed From [Hz]*.
6. When the motor has ramped down to stop, press [OK]. The *parameter 4-64 Semi-Auto Bypass Set-up* automatically resets to off. The drive stays in hand on mode until [Off] or [Auto On] is pressed.

If the frequencies for a certain resonance band are not registered in the right order (frequency values stored in *parameter 4-63 Bypass Speed To [Hz]* are \geq the values in *parameter 4-61 Bypass Speed From [Hz]*), or if they do not have the same numbers of registrations for the *parameter 4-61 Bypass Speed From [Hz]* and *parameter 4-63 Bypass Speed To [Hz]*, all registrations are canceled and the following message is shown: *Collected speed areas overlapping or not determined. Press [Cancel] to abort.*

4.7 Parameter Group 5-** Digital In/Out

Parameter group for configuration of the digital input and output.

4.7.1 5-0* Digital I/O mode

Parameters for configuring the I/O mode, NPN or PNP, and configuring I/O for Input or Output.

5-00 Digital Input Mode

Default value: [0] PNP	Parameter type: Option	2-setup: 1 setup
Conversion index: -	Data type: u_int8	Change during operation: False

Set NPN or PNP mode for digital inputs 18, 19, and 27.

Table 128: Option:

[0]	PNP	Action on positive directional pulses (0). PNP systems are pulled down to ground (GND).
[1]	NPN	Action on negative directional pulses (1). NPN systems are pulled up to +24 V internally in the drive.

5-01 Terminal 27 Mode

Default value: [0] Input	Parameter type: Option	2-setup: All setups
Conversion index: -	Data type: u_int8	Change during operation: True

Table 129: Option:

[0]	Input	Define terminal 27 as a digital input.
[1]	Output	Define terminal 27 as a digital output.

5-02 Terminal 29 Mode

Default value: [0] Input	Parameter type: Option	2-setup: All setups
Conversion index: -	Data type: u_int8	Change during operation: True

Table 130: Option:

[0]	Input	Define terminal 29 as a digital input.
[1]	Output	Define terminal 29 as a digital output.

5-03 Digital Input 29 Mode

Default value: [0] PNP	Parameter type: Option	2-setup: 1 setup
Conversion index: -	Data type: u_int8	Change during operation: False

Table 131: Option:

[0]	PNP	Set to PNP mode for digital inputs 29.
[1]	NPN	Set to NPN mode for digital inputs 29.

4.7.2 5-1* Digital Inputs

Parameters for configuring the input functions for the input terminals. The digital inputs are used for selecting various functions in the drive.

Table 132: Selected Preset Reference (Parameter 3-10 Preset Reference)

Selected preset reference:	Preset reference bit 2	Preset reference bit 1	Preset reference bit 0
Preset reference 0	0	0	0
Preset reference 1	0	0	1
Preset reference 2	0	1	0
Preset reference 3	0	1	1
Preset reference 4	1	0	0
Preset reference 5	1	0	1
Preset reference 6	1	1	0
Preset reference 7	1	1	1

Table 133: Selected Multi Fire Mode Preset Reference (Parameter 24-08 Mul FM Preset Reference)

Selected multi fire mode preset reference:	Fire mode reference bit 2	Fire mode reference bit 1	Fire mode reference bit 0
Fire mode preset reference 0	0	0	0
Fire mode preset reference 1	0	0	1
Fire mode preset reference 2	0	1	0
Fire mode preset reference 3	0	1	1
Fire mode preset reference 4	1	0	0
Fire mode preset reference 5	1	0	1
Fire mode preset reference 6	1	1	0
Fire mode preset reference 7	1	1	1

5-10 Terminal 18 Digital Input

Default value: [8] Start	Parameter type: Option	2-setup: All setups
Conversion index: -	Data type: u_int8	Change during operation: True

Parameter for configuring the input function on input terminal 18.

Table 134: Option:

[0]	No operation	No reaction to signals transmitted to the terminal.
[1]	Reset	Reset the drive after a trip/alarm. Trip lock alarms can be reset.
[2]	Coast inverse	Leave the motor in free mode. Logic 0⇒coast stop.
[3]	Coast and reset inverse	Reset and coast stop inverted input (NC). Leaves the motor in free mode and resets the drive. Logic 0⇒coast stop and reset.
[4]	Quick stop inverse	Inverted input (NC). Generates a stop in accordance with the quick-stop ramp time set in <i>parameter 3-81 Quick Stop Ramp Time</i> . After ramping down, the shaft is in free mode.
[5]	DC-brake inverse	Inverted input for DC braking (NC). Stops the motor by energizing it with DC current for a certain time period, see <i>parameter 2-01 DC Brake Current</i> . The function is only active when the value in <i>parameter 2-02 DC Braking Time</i> is different from 0. This selection is not possible when <i>parameter 1-10 Motor Construction</i> is set to [1] PM non-salient SPM.
[6]	Stop inverse	The stop inverse function generates the stop function when the selected terminal goes from logical level 1 to 0 (not latched). Stop is performed according to selected ramp time.
[7]	External Interlock	Same function as coast stop, inverse, but external interlock generates the alarm message <i>external fault</i> on the display when the terminal programmed for coast inverse is logic 0. If programmed for external interlock, the alarm message is also active via digital outputs and relay outputs. If the cause for the external interlock is removed, the alarm can be reset using a digital input, fieldbus, or the [Reset] key.
[8]	Start	Select start for a start/stop command. Logic 1 = start, logic 0 = stop. (Default digital input 18).
[9]	Latched start	If a pulse is applied for a minimum of 2 ms, the motor starts. The motor stops when stop inverse is activated.
[10]	Reversing	Change direction of motor shaft rotation. The reversing signal only changes the direction of rotation, it does not activate the start function. Select [2] <i>Both directions</i> in <i>parameter 4-10 Motor Speed Direction</i> . 0 = normal, 1 = reversing.

[11]	Start reversing	Use for start/stop and for reversing at the same time. Signals on [8] Start are not allowed at the same time. 0 = stop, 1 = start reversing.
[14]	Jog	Used for activating jog speed. See <i>parameter 3-11 Jog Speed [Hz]</i> . (Default digital input 29).
[16]	Preset ref bit 0	Enable a selection of 1 of the 8 preset references according to Table 132 .
[17]	Preset ref bit 1	Enable a selection of 1 of the 8 preset references according to Table 132 .
[18]	Preset ref bit 2	Enable a selection of 1 of the 8 preset references according to Table 132 .
[19]	Freeze reference	Freeze actual reference. The frozen reference is now the point of enable/condition for speed up and speed down to be used. If speed up/speed down is used, a speed change always follows ramp 2 (<i>parameter 3-51 Ramp 2 Ramp Up Time</i> and <i>parameter 3-52 Ramp 2 Ramp Down Time</i>) in the range <i>parameter 3-02 Minimum Reference</i> - <i>parameter 3-03 Maximum Reference</i> .
[20]	Freeze output	Freezes actual reference. The frozen reference is now the point of enable/condition for speed up and speed down to be used. If speed up/speed down is used, the speed change always follows ramp 2.
[21]	Speed up	For digital control of the up/down speed (motor potentiometer). Activate this function by selecting either freeze reference or freeze output. When speed up is activated for less than 400 ms, the resulting reference is increased by 0.1%. If speed up is activated for more than 400 ms, the resulting reference ramps according to ramp 1 in <i>parameter 3-41 Ramp 1 Ramp Up Time</i> .
[22]	Speed down	Same as [21] Speed up, but reference decreases.
[23]	Set-up select bit 0	Selects 1 of the 2 setups. Set <i>parameter 0-10 Active Set-up</i> to multi setup.
[34]	Ramp bit 0	Select which ramp to use. Logic 0 selects ramp 1, while logic 1 selects ramp 2.
[37]	Fire Mode	A signal applied puts the into fire mode and disregards all other commands. See <i>parameter group 24-0* Fire Mode</i> .
[52]	Run permissive	The input terminal, for which the run permissive is programmed, must be logic 1 before a start command can be accepted. Run permissive has a logic AND function related to the terminal, which is programmed for [8] Start, [14] Jog, or [20] Freeze Output. To start running the motor, both conditions must be fulfilled. If run permissive is programmed on multiple terminals, run permissive only has to be logic 1 on 1 of the terminals for the function to be carried out. Run permissive does not affect the digital output signal for run request ([8] Start, [14] Jog, or [20] Freeze Output) programmed in <i>parameter group 5-3* Digital Outputs</i> , or <i>parameter group 5-4* Relays</i> . <div style="text-align: center;">NOTICE</div> <p>If no run permissive signal is applied but either run, jog, or freeze commands is activated, the status line in the display shows either <i>Run Requested</i>, <i>Jog Requested</i>, or <i>Freeze Requested</i>.</p>
[53]	Hand start	A signal applied puts the drive into hand-on mode as if [Hand On] is pressed and a normal stop command is overridden. If the signal is disconnected, the motor stops. To make any other start commands valid, assign another digital input to <i>Auto Start</i> and apply a signal. The [Hand On] and [Auto On] keys have no impact. The [Off] key overrides <i>Hand Start</i> and <i>Auto Start</i> . Press either [Hand On] or [Auto On] to reactivate <i>Hand Start</i> and <i>Auto Start</i> . If there is no signal on <i>Hand Start</i> or <i>Auto Start</i> , the motor stops regardless of any normal start command applied. If a signal is applied to both <i>Hand Start</i> and <i>Auto Start</i> , the function is <i>Auto Start</i> .
[54]	Auto start	A signal applied puts the drive into auto-on mode as if [Auto On] is pressed. See also [53] <i>Hand Start</i> .
[60]	Counter A (up)	Input for increment counting in the SLC counter.
[61]	Counter A (down)	Input for decrement counting in the SLC counter.

[62]	Reset Counter A	Input for reset of counter A.
[63]	Counter B (up)	Input for increment counting in the SLC counter.
[64]	Counter B (down)	Input for decrement counting in the SLC counter.
[65]	Reset Counter B	Input for reset of counter B.
[101]	Sleep	A signal applied puts the drive into sleep mode.
[120]	Lead Pump Start	A signal applied puts the lead pump into start mode.
[121]	Lead Pump Alternation	A signal applied puts the lead pump into alternation mode.
[130]	Pump 1 Interlock	A signal applied puts the pump 1 into interlock mode.
[131]	Pump 2 Interlock	A signal applied puts the pump 2 into interlock mode.
[132]	Pump 3 Interlock	A signal applied puts the pump 3 into interlock mode.
[133]	Pump 4 Interlock	A signal applied puts the pump 4 into interlock mode.
[134]	Pump 5 Interlock	A signal applied puts the pump 5 into interlock mode.
[190]	Fire Mode Ref Bit 0	Enable a selection of 1 of the 8 fire mode references according to Table 133 .
[191]	Fire Mode Ref Bit 1	Enable a selection of 1 of the 8 fire mode references according to Table 133 .
[192]	Fire Mode Ref Bit 2	Enable a selection of 1 of the 8 fire mode references according to Table 133 .

5-11 Terminal 19 Digital Input

Default value: [0] No operation	Parameter type: Option	2-setup: All setups
Conversion index: -	Data type: u_int8	Change during operation: True

Parameter for configuring the input function on input terminal 19.

Table 135: Option:

[0]	No operation	No reaction to signals transmitted to the terminal.
[1]	Reset	Reset the after a trip/alarm. Trip lock alarms can be reset.
[2]	Coast inverse	Leave the motor in free mode. Logic 0⇒ coast stop.
[3]	Coast and reset inverse	Reset and coast stop inverted input (NC). Leaves the motor in free mode and resets the . Logic 0⇒ coast stop and reset.
[4]	Quick stop inverse	Inverted input (NC). Generates a stop in accordance with the quick-stop ramp time set in <i>parameter 3-81 Quick Stop Ramp Time</i> . After ramping down, the shaft is in free mode.

[5]	DC-brake inverse	Inverted input for DC braking (NC). Stops the motor by energizing it with DC current for a certain time period, see <i>parameter 2-01 DC Brake Current</i> . The function is only active when the value in <i>parameter 2-02 DC Braking Time</i> is different from 0. This selection is not possible when <i>parameter 1-10 Motor Construction</i> is set to [1] <i>PM non-salient SPM</i> .
[6]	Stop inverse	The stop inverse function generates the stop function when the selected terminal goes from logical level 1 to 0 (not latched). Stop is performed according to selected ramp time.
[7]	External Interlock	Same function as coast stop, inverse, but external interlock generates the alarm message <i>external fault</i> on the display when the terminal programmed for coast inverse is logic 0. If programmed for external interlock, the alarm message is also active via digital outputs and relay outputs. If the cause for the external interlock is removed, the alarm can be reset using a digital input, fieldbus, or the [Reset] key.
[8]	Start	Select start for a start/stop command. Logic 1 = start, logic 0 = stop. (Default digital input 18).
[9]	Latched start	If a pulse is applied for a minimum of 2 ms, the motor starts. The motor stops when stop inverse is activated.
[10]	Reversing	Change direction of motor shaft rotation. The reversing signal only changes the direction of rotation, it does not activate the start function. Select [2] <i>Both directions</i> in <i>parameter 4-10 Motor Speed Direction</i> . 0 = normal, 1 = reversing.
[11]	Start reversing	Use for start/stop and for reversing at the same time. Signals on [8] <i>Start</i> are not allowed at the same time. 0 = stop, 1 = start reversing.
[14]	Jog	Used for activating jog speed. See <i>parameter 3-11 Jog Speed [Hz]</i> . (Default digital input 29).
[16]	Preset ref bit 0	Enable a selection of 1 of the 8 preset references according to Table 132 .
[17]	Preset ref bit 1	Enable a selection of 1 of the 8 preset references according to Table 132 .
[18]	Preset ref bit 2	Enable a selection of 1 of the 8 preset references according to Table 132 .
[19]	Freeze reference	Freeze actual reference. The frozen reference is now the point of enable/condition for speed up and speed down to be used. If speed up/speed down is used, a speed change always follows ramp 2 (<i>parameter 3-51 Ramp 2 Ramp Up Time</i> and <i>parameter 3-52 Ramp 2 Ramp Down Time</i>) in the range <i>parameter 3-02 Minimum Reference</i> - <i>parameter 3-03 Maximum Reference</i> .
[20]	Freeze output	Freezes actual reference. The frozen reference is now the point of enable/condition for speed up and speed down to be used. If speed up/speed down is used, the speed change always follows ramp 2.
[21]	Speed up	For digital control of the up/down speed (motor potentiometer). Activate this function by selecting either freeze reference or freeze output. When speed up is activated for less than 400 ms, the resulting reference is increased by 0.1%. If speed up is activated for more than 400 ms, the resulting reference ramps according to ramp 1 in <i>parameter 3-41 Ramp 1 Ramp Up Time</i> .
[22]	Speed down	Same as [21] <i>Speed up</i> , but reference decreases.
[23]	Set-up select bit 0	Selects 1 of the 2 setups. Set <i>parameter 0-10 Active Set-up</i> to multi setup.
[34]	Ramp bit 0	Select which ramp to use. Logic 0 selects ramp 1, while logic 1 selects ramp 2.
[37]	Fire Mode	A signal applied puts the into fire mode and disregards all other commands. See <i>parameter group 24-0* Fire Mode</i> .
[52]	Run permissive	The input terminal, for which the run permissive is programmed, must be logic 1 before a start command can be accepted. Run permissive has a logic AND function related to the terminal, which is programmed for [8] <i>Start</i> , [14] <i>Jog</i> , or [20] <i>Freeze Output</i> . To start running the motor, both conditions must be fulfilled. If run permissive is programmed on multiple terminals, run permissive only has to be logic 1 on 1 of the terminals for the function to be carried out. Run permissive does not affect the digital output signal for run request ([8] <i>Start</i> , [14] <i>Jog</i> , or [20] <i>Freeze Output</i>) programmed in <i>parameter group 5-3* Digital Outputs</i> , or <i>parameter group 5-4* Relays</i> .

NOTICE		
		If no run permissive signal is applied but either run, jog, or freeze commands is activated, the status line in the display shows either <i>Run Requested</i> , <i>Jog Requested</i> , or <i>Freeze Requested</i> .
[53]	Hand start	A signal applied puts the drive into hand-on mode as if [Hand On] is pressed and a normal stop command is overridden. If the signal is disconnected, the motor stops. To make any other start commands valid, assign another digital input to <i>Auto Start</i> and apply a signal. The [Hand On] and [Auto On] keys have no impact. The [Off] key overrides <i>Hand Start</i> and <i>Auto Start</i> . Press either [Hand On] or [Auto On] to reactivate <i>Hand Start</i> and <i>Auto Start</i> . If there is no signal on <i>Hand Start</i> or <i>Auto Start</i> , the motor stops regardless of any normal start command applied. If a signal is applied to both <i>Hand Start</i> and <i>Auto Start</i> , the function is <i>Auto Start</i> .
[54]	Auto start	A signal applied puts the drive into auto-on mode as if [Auto On] is pressed. See also [53] <i>Hand Start</i> .
[60]	Counter A (up)	Input for increment counting in the SLC counter.
[61]	Counter A (down)	Input for decrement counting in the SLC counter.
[62]	Reset Counter A	Input for reset of counter A.
[63]	Counter B (up)	Input for increment counting in the SLC counter.
[64]	Counter B (down)	Input for decrement counting in the SLC counter.
[65]	Reset Counter B	Input for reset of counter B.
[101]	Sleep	A signal applied puts the drive into sleep mode.
[120]	Lead Pump Start	A signal applied puts the lead pump into start mode.
[121]	Lead Pump Alternation	A signal applied puts the lead pump into alternation mode.
[130]	Pump 1 Interlock	A signal applied puts pump 1 into interlock mode.
[131]	Pump 2 Interlock	A signal applied puts pump 2 into interlock mode.
[132]	Pump 3 Interlock	A signal applied puts pump 3 into interlock mode.
[133]	Pump 4 Interlock	A signal applied puts pump 4 into interlock mode.
[134]	Pump 5 Interlock	A signal applied puts pump 5 into interlock mode.
[190]	Fire Mode Ref Bit 0	Enable a selection of 1 of the 8 fire mode references according to Table 133 .
[191]	Fire Mode Ref Bit 1	Enable a selection of 1 of the 8 fire mode references according to Table 133 .
[192]	Fire Mode Ref Bit 2	Enable a selection of 1 of the 8 fire mode references according to Table 133 .

5-12 Terminal 27 Digital Input

Default value: [2] Coast inverse	Parameter type: Option	2-setup: All setups
Conversion index: -	Data type: u_int8	Change during operation: True

Parameter for configuring the input function on input terminal 27.

Table 136: Option:

[0]	No operation	No reaction to signals transmitted to the terminal.
[1]	Reset	Reset the after a trip/alarm. Trip lock alarms can be reset.
[2]	Coast inverse	Leave the motor in free mode. Logic 0⇒ coast stop.
[3]	Coast and reset inverse	Reset and coast stop inverted input (NC). Leaves the motor in free mode and resets the drive. Logic 0⇒ coast stop and reset.
[4]	Quick stop inverse	Inverted input (NC). Generates a stop in accordance with the quick-stop ramp time set in <i>parameter 3-81 Quick Stop Ramp Time</i> . After ramping down, the shaft is in free mode.
[5]	DC-brake inverse	Inverted input for DC braking (NC). Stops the motor by energizing it with DC current for a certain time period, see <i>parameter 2-01 DC Brake Current</i> . The function is only active when the value in <i>parameter 2-02 DC Braking Time</i> is different from 0. This selection is not possible when <i>parameter 1-10 Motor Construction</i> is set to [1] <i>PM non-salient SPM</i> .
[6]	Stop inverse	The stop inverse function generates the stop function when the selected terminal goes from logical level 1 to 0 (not latched). Stop is performed according to selected ramp time.
[7]	External Interlock	Same function as coast stop, inverse, but external interlock generates the alarm message <i>external fault</i> on the display when the terminal programmed for coast inverse is logic 0. If programmed for external interlock, the alarm message is also active via digital outputs and relay outputs. If the cause for the external interlock is removed, the alarm can be reset using a digital input, fieldbus, or the [Reset] key.
[8]	Start	Select start for a start/stop command. Logic 1 = start, logic 0 = stop. (Default digital input 18).
[9]	Latched start	If a pulse is applied for a minimum of 2 ms, the motor starts. The motor stops when stop inverse is activated.
[10]	Reversing	Change direction of motor shaft rotation. The reversing signal only changes the direction of rotation, it does not activate the start function. Select [2] <i>Both directions</i> in <i>parameter 4-10 Motor Speed Direction</i> . 0 = normal, 1 = reversing.
[11]	Start reversing	Use for start/stop and for reversing at the same time. Signals on [8] <i>Start</i> are not allowed at the same time. 0 = stop, 1 = start reversing.
[14]	Jog	Used for activating jog speed. See <i>parameter 3-11 Jog Speed [Hz]</i> . (Default digital input 29).
[16]	Preset ref bit 0	Enable a selection of 1 of the 8 preset references according to Table 132 .
[17]	Preset ref bit 1	Enable a selection of 1 of the 8 preset references according to Table 132 .
[18]	Preset ref bit 2	Enable a selection of 1 of the 8 preset references according to Table 132 .
[19]	Freeze reference	Freeze actual reference. The frozen reference is now the point of enable/condition for speed up and speed down to be used. If speed up/speed down is used, a speed change always follows ramp 2 (<i>parameter 3-51 Ramp 2 Ramp Up Time</i> and <i>parameter 3-52 Ramp 2 Ramp Down Time</i>) in the range <i>parameter 3-02 Minimum Reference</i> - <i>parameter 3-03 Maximum Reference</i> .
[20]	Freeze output	Freezes actual reference. The frozen reference is now the point of enable/condition for speed up and speed down to be used. If speed up/speed down is used, the speed change always follows ramp 2.
[21]	Speed up	For digital control of the up/down speed (motor potentiometer). Activate this function by selecting either freeze reference or freeze output. When speed up is activated for less than 400 ms, the resulting

		reference is increased by 0.1%. If speed up is activated for more than 400 ms, the resulting reference ramps according to ramp 1 in <i>parameter 3-41 Ramp 1 Ramp Up Time</i> .
[22]	Speed down	Same as [21] <i>Speed up</i> , but reference decreases.
[23]	Set-up select bit 0	Selects 1 of the 2 setups. Set <i>parameter 0-10 Active Set-up</i> to multi setup.
[34]	Ramp bit 0	Select which ramp to use. Logic 0 selects ramp 1, while logic 1 selects ramp 2.
[37]	Fire Mode	A signal applied puts the into fire mode and disregards all other commands. See <i>parameter group 24-0* Fire Mode</i> .
[52]	Run permissive	<p>The input terminal, for which the run permissive is programmed, must be logic 1 before a start command can be accepted. Run permissive has a logic AND function related to the terminal, which is programmed for [8] <i>Start</i>, [14] <i>Jog</i>, or [20] <i>Freeze Output</i>. To start running the motor, both conditions must be fulfilled. If run permissive is programmed on multiple terminals, run permissive only has to be logic 1 on 1 of the terminals for the function to be carried out. Run permissive does not affect the digital output signal for run request ([8] <i>Start</i>, [14] <i>Jog</i>, or [20] <i>Freeze Output</i>) programmed in <i>parameter group 5-3* Digital Outputs</i>, or <i>parameter group 5-4* Relays</i>.</p> <div style="text-align: center; background-color: #cccccc; padding: 5px;">NOTICE</div> <p>If no run permissive signal is applied but either run, jog, or freeze commands is activated, the status line in the display shows either <i>Run Requested</i>, <i>Jog Requested</i>, or <i>Freeze Requested</i>.</p>
[53]	Hand start	A signal applied puts the drive into hand-on mode as if [Hand On] is pressed and a normal stop command is overridden. If the signal is disconnected, the motor stops. To make any other start commands valid, assign another digital input to <i>Auto Start</i> and apply a signal. The [Hand On] and [Auto On] keys have no impact. The [Off] key overrides <i>Hand Start</i> and <i>Auto Start</i> . Press either [Hand On] or [Auto On] to reactivate <i>Hand Start</i> and <i>Auto Start</i> . If there is no signal on <i>Hand Start</i> or <i>Auto Start</i> , the motor stops regardless of any normal start command applied. If a signal is applied to both <i>Hand Start</i> and <i>Auto Start</i> , the function is <i>Auto Start</i> .
[54]	Auto start	A signal applied puts the drive into auto-on mode as if [Auto On] is pressed. See also [53] <i>Hand Start</i> .
[60]	Counter A (up)	Input for increment counting in the SLC counter.
[61]	Counter A (down)	Input for decrement counting in the SLC counter.
[62]	Reset Counter A	Input for reset of counter A.
[63]	Counter B (up)	Input for increment counting in the SLC counter.
[64]	Counter B (down)	Input for decrement counting in the SLC counter.
[65]	Reset Counter B	Input for reset of counter B.
[101]	Sleep	A signal applied puts the drive into sleep mode.
[120]	Lead Pump Start	A signal applied puts the lead pump into start mode.
[121]	Lead Pump Alternation	A signal applied puts the lead pump into alternation mode.
[130]	Pump 1 Interlock	A signal applied puts pump 1 into interlock mode.

[131]	Pump 2 Interlock	A signal applied puts pump 2 into interlock mode.
[132]	Pump 3 Interlock	A signal applied puts pump 3 into interlock mode.
[133]	Pump 4 Interlock	A signal applied puts pump 4 into interlock mode.
[134]	Pump 5 Interlock	A signal applied puts pump 5 into interlock mode.
[190]	Fire Mode Ref Bit 0	Enable a selection of 1 of the 8 fire mode references according to Table 133 .
[191]	Fire Mode Ref Bit 1	Enable a selection of 1 of the 8 fire mode references according to Table 133 .
[192]	Fire Mode Ref Bit 2	Enable a selection of 1 of the 8 fire mode references according to Table 133 .

5-13 Terminal 29 Digital Input

Default value: [14] Jog	Parameter type: Option	2-setup: All setups
Conversion index: -	Data type: u_int8	Change during operation: True

Parameter for configuring the input function on input terminal 29.

Table 137: Option:

[0]	No operation	No reaction to signals transmitted to the terminal.
[1]	Reset	Reset the after a trip/alarm. Trip lock alarms can be reset.
[2]	Coast inverse	Leave the motor in free mode. Logic 0 ⇒ coast stop.
[3]	Coast and reset inverse	Reset and coast stop inverted input (NC). Leaves the motor in free mode and resets the . Logic 0 ⇒ coast stop and reset.
[4]	Quick stop inverse	Inverted input (NC). Generates a stop in accordance with the quick-stop ramp time set in <i>parameter 3-81 Quick Stop Ramp Time</i> . After ramping down, the shaft is in free mode.
[5]	DC-brake inverse	Inverted input for DC braking (NC). Stops the motor by energizing it with DC current for a certain time period, see <i>parameter 2-01 DC Brake Current</i> . The function is only active when the value in <i>parameter 2-02 DC Braking Time</i> is different from 0. This selection is not possible when <i>parameter 1-10 Motor Construction</i> is set to [1] <i>PM non-salient SPM</i> .
[6]	Stop inverse	The stop inverse function generates the stop function when the selected terminal goes from logical level 1 to 0 (not latched). Stop is performed according to selected ramp time.
[7]	External Interlock	Same function as coast stop, inverse, but external interlock generates the alarm message <i>external fault</i> on the display when the terminal programmed for coast inverse is logic 0. If programmed for external interlock, the alarm message is also active via digital outputs and relay outputs. If the cause for the external interlock is removed, the alarm can be reset using a digital input, fieldbus, or the [Reset] key.
[8]	Start	Select start for a start/stop command. Logic 1 = start, logic 0 = stop. (Default digital input 18).
[9]	Latched start	If a pulse is applied for a minimum of 2 ms, the motor starts. The motor stops when stop inverse is activated.
[10]	Reversing	Change direction of motor shaft rotation. The reversing signal only changes the direction of rotation, it does not activate the start function. Select [2] <i>Both directions</i> in <i>parameter 4-10 Motor Speed Direction</i> . 0 = normal, 1 = reversing.

[11]	Start reversing	Use for start/stop and for reversing at the same time. Signals on [8] Start are not allowed at the same time. 0 = stop, 1 = start reversing.
[14]	Jog	Used for activating jog speed. See <i>parameter 3-11 Jog Speed [Hz]</i> . (Default digital input 29).
[16]	Preset ref bit 0	Enable a selection of 1 of the 8 preset references according to Table 132 .
[17]	Preset ref bit 1	Enable a selection of 1 of the 8 preset references according to Table 132 .
[18]	Preset ref bit 2	Enable a selection of 1 of the 8 preset references according to Table 132 .
[19]	Freeze reference	Freeze actual reference. The frozen reference is now the point of enable/condition for speed up and speed down to be used. If speed up/speed down is used, a speed change always follows ramp 2 (<i>parameter 3-51 Ramp 2 Ramp Up Time</i> and <i>parameter 3-52 Ramp 2 Ramp Down Time</i>) in the range <i>parameter 3-02 Minimum Reference - parameter 3-03 Maximum Reference</i> .
[20]	Freeze output	Freezes actual reference. The frozen reference is now the point of enable/condition for speed up and speed down to be used. If speed up/speed down is used, the speed change always follows ramp 2.
[21]	Speed up	For digital control of the up/down speed (motor potentiometer). Activate this function by selecting either freeze reference or freeze output. When speed up is activated for less than 400 ms, the resulting reference is increased by 0.1%. If speed up is activated for more than 400 ms, the resulting reference ramps according to ramp 1 in <i>parameter 3-41 Ramp 1 Ramp Up Time</i> .
[22]	Speed down	Same as [21] Speed up, but reference decreases.
[23]	Set-up select bit 0	Selects 1 of the 2 setups. Set <i>parameter 0-10 Active Set-up</i> to multi setup.
[32]	Pulse input	Select pulse input when using a pulse sequence as either reference or feedback. Scaling is done in <i>parameter group 5-5* Pulse Input</i> . Available only for terminal 29.
[34]	Ramp bit 0	Select which ramp to use. Logic 0 selects ramp 1, while logic 1 selects ramp 2.
[37]	Fire Mode	A signal applied puts the drive into fire mode and disregards all other commands. See <i>parameter group 24-0* Fire Mode</i> .
[52]	Run permissive	The input terminal, for which the run permissive is programmed, must be logic 1 before a start command can be accepted. Run permissive has a logic AND function related to the terminal, which is programmed for [8] Start, [14] Jog, or [20] Freeze Output. To start running the motor, both conditions must be fulfilled. If run permissive is programmed on multiple terminals, run permissive only has to be logic 1 on 1 of the terminals for the function to be carried out. Run permissive does not affect the digital output signal for run request ([8] Start, [14] Jog, or [20] Freeze Output) programmed in <i>parameter group 5-3* Digital Outputs</i> , or <i>parameter group 5-4* Relays</i> .
<p>NOTICE</p> <p>If no run permissive signal is applied but either run, jog, or freeze commands is activated, the status line in the display shows either <i>Run Requested</i>, <i>Jog Requested</i>, or <i>Freeze Requested</i>.</p>		
[53]	Hand start	A signal applied puts the drive into hand-on mode as if [Hand On] is pressed and a normal stop command is overridden. If the signal is disconnected, the motor stops. To make any other start commands valid, assign another digital input to <i>Auto Start</i> and apply a signal. The [Hand On] and [Auto On] keys have no impact. The [Off] key overrides <i>Hand Start</i> and <i>Auto Start</i> . Press either [Hand On] or [Auto On] to reactivate <i>Hand Start</i> and <i>Auto Start</i> . If there is no signal on <i>Hand Start</i> or <i>Auto Start</i> , the motor stops regardless of any normal start command applied. If a signal is applied to both <i>Hand Start</i> and <i>Auto Start</i> , the function is <i>Auto Start</i> .
[54]	Auto start	A signal applied puts the drive into auto-on Jog mode as if [Auto On] is pressed. See also [53] <i>Hand Start</i> .
[60]	Counter A (up)	Input for increment counting in the SLC counter.

[61]	Counter A (down)	Input for decrement counting in the SLC counter.
[62]	Reset Counter A	Input for reset of counter A.
[63]	Counter B (up)	Input for increment counting in the SLC counter.
[64]	Counter B (down)	Input for decrement counting in the SLC counter.
[65]	Reset Counter B	Input for reset of counter B.
[101]	Sleep	A signal applied puts the drive into sleep mode.
[120]	Lead Pump Start	A signal applied puts the lead pump into start mode.
[121]	Lead Pump Alternation	A signal applied puts the lead pump into alternation mode.
[130]	Pump 1 Interlock	A signal applied puts pump 1 into interlock mode.
[131]	Pump 2 Interlock	A signal applied puts pump 2 into interlock mode.
[132]	Pump 3 Interlock	A signal applied puts pump 3 into interlock mode.
[133]	Pump 4 Interlock	A signal applied puts pump 4 into interlock mode.
[134]	Pump 5 Interlock	A signal applied puts pump 5 into interlock mode.
[190]	Fire Mode Ref Bit 0	Enable a selection of 1 of the 8 fire mode references according to Table 133 .
[191]	Fire Mode Ref Bit 1	Enable a selection of 1 of the 8 fire mode references according to Table 133 .
[192]	Fire Mode Ref Bit 2	Enable a selection of 1 of the 8 fire mode references according to Table 133 .

4.7.3 5-3* Digital Outputs

Parameters for configuring the output functions for the output terminals.

5-30 Terminal 27 Digital Output

Default value: [0] No operation	Parameter type: Option	2-setup: All setups
Conversion index: -	Data type: u_int8	Change during operation: True

Select the function for terminal 27 digital output.

Table 138: Option:

[0]	No operation	No operation.
[1]	Control Ready	The control board receives supply voltage.
[2]	Drive ready	The drive is ready for operation and applies a supply signal on the control board.

[3]	Drive ready/remote control	The drive is ready for operation in auto-on mode.
[4]	Standby/no warning	The drive is ready for operation. No start or stop command is given. No warnings are present.
[5]	Drive running	The motor runs.
[6]	Running/no warning	The motor runs, and no warnings are present.
[7]	Run in range/no warning	The motor runs within the programmed current ranges, see <i>parameter 4-50 Warning Current Low</i> and <i>parameter 4-51 Warning Current High</i> . No warnings are present.
[8]	Run on ref/no warning	The motor runs at reference speed and with no warnings.
[9]	Alarm	An alarm activates output.
[10]	Alarm or warning	An alarm or warning activates output.
[12]	Out of current range	The motor current is outside the ranges set in <i>parameter 4-50 Warning Current Low</i> and <i>parameter 4-51 Warning Current High</i> .
[13]	Below current, low	The motor current is lower than the limit set in <i>parameter 4-50 Warning Current Low</i> .
[14]	Above current, high	The motor current is higher than the limit set in <i>parameter 4-51 Warning Current High</i> .
[16]	Below speed, low	The drive output speed is lower than the limit set in <i>parameter 4-40 Warning Freq. Low</i> .
[17]	Above speed, high	The drive output speed is higher than the limit set in <i>parameter 4-41 Warning Freq. High</i> .
[19]	Below feedback, low	The feedback is lower than the limit set in <i>parameter 4-56 Warning Feedback Low</i> .
[20]	Above feedback, high	The feedback is higher than the limit set in <i>parameter 4-57 Warning Feedback High</i> .
[21]	Thermal warning	The thermal warning turns on when the temperature exceeds the limit in motor, drive, or thermistor.
[22]	Ready, no thermal warning	The drive is ready for operation and no thermal warning is present.
[23]	Remote, ready, no thermal warning	The drive is ready for operation in auto mode, and no thermal warning is present.
[24]	Ready, Voltage OK	The drive is ready for operation and mains voltage is within the specified voltage range.
[25]	Reverse	The motor runs/is ready to run clockwise when logic = 0 and counterclockwise when logic = 1. Output changes as soon as reversing signal is applied.
[26]	Bus OK	Active communication (no timeout) via serial communication port.
[35]	External Interlock	See [7] <i>External Interlock</i> in the <i>parameter group 5-1* Digital Input</i> .
[36]	Control word bit 11	Bit 11 in control word controls the relay.
[37]	Control word bit 12	Bit 12 in control word controls the relay.
[41]	Below reference, low	The reference is lower than the limit set in <i>parameter 4-54 Warning Reference Low</i> .
[42]	Above ref, high	The reference is higher than the limit set in <i>parameter 4-55 Warning Reference High</i> .
[45]	Bus Control	The output is configured in <i>parameter 5-90 Digital & Relay Bus Control</i> .
[60]	Comparator 0	See <i>parameter group 13-1* Comparators</i> . If comparator 0 is evaluated as true, the output goes high. Otherwise, it is low.

[61]	Comparator 1	See <i>parameter group 13-1* Comparators</i> . If comparator 1 is evaluated as true, the output goes high. Otherwise, it is low.
[62]	Comparator 2	See <i>parameter group 13-1* Comparators</i> . If comparator 2 is evaluated as true, the output goes high. Otherwise, it is low.
[63]	Comparator 3	See <i>parameter group 13-1* Comparators</i> . If comparator 3 is evaluated as true, the output goes high. Otherwise, it is low.
[64]	Comparator 4	See <i>parameter group 13-1* Comparators</i> . If comparator 4 is evaluated as true, the output goes high. Otherwise, it is low.
[65]	Comparator 5	See <i>parameter group 13-1* Comparators</i> . If comparator 5 is evaluated as true, the output goes high. Otherwise, it is low.
[70]	Logic rule 0	See <i>parameter group 13-4* Logic Rules</i> . If logic rule 0 is evaluated as true, the output goes high. Otherwise, it is low.
[71]	Logic rule 1	See <i>parameter group 13-4* Logic Rules</i> . If logic rule 1 is evaluated as true, the output goes high. Otherwise, it is low.
[72]	Logic rule 2	See <i>parameter group 13-4* Logic Rules</i> . If logic rule 2 is evaluated as true, the output goes high. Otherwise, it is low.
[73]	Logic rule 3	See <i>parameter group 13-4* Logic Rules</i> . If logic rule 3 is evaluated as true, the output goes high. Otherwise, it is low.
[74]	Logic rule 4	See <i>parameter group 13-4* Logic Rules</i> . If logic rule 4 is evaluated as true, the output goes high. Otherwise, it is low.
[75]	Logic rule 5	See <i>parameter group 13-4* Logic Rules</i> . If logic rule 5 is evaluated as true, the output goes high. Otherwise, it is low.
[80]	SL digital output A	See <i>parameter 13-52 SL Controller Action</i> . The input goes high whenever the smart logic action [38] <i>Set dig. out. A high</i> is executed. The input goes low whenever the smart logic [32] <i>Action Set dig. out. A low</i> is executed.
[81]	SL digital output B	See <i>parameter 13-52 SL Controller Action</i> . The input goes high whenever the smart logic action [39] <i>Set dig. out. B high</i> is executed. The input goes low whenever the smart logic [33] <i>Action Set dig. out. B low</i> is executed.
[82]	SL digital output C	See <i>parameter 13-52 SL Controller Action</i> . The input goes high whenever the smart logic action [40] <i>Set dig. out. C high</i> is executed. The input goes low whenever the smart logic [34] <i>Action Set dig. out. C low</i> is executed.
[83]	SL digital output D	See <i>parameter 13-52 SL Controller Action</i> . The input goes high whenever the smart logic action [41] <i>Set dig. out. D high</i> is executed. The input goes low whenever the smart logic [35] <i>Action Set dig. out. D low</i> is executed.
[160]	No alarm	The output is high when no alarm is present.
[161]	Running reverse	The output is high when the drive is running counterclockwise (the logical product of the status bits running and reverse).
[165]	Local ref. active	The output is high when local reference is activated by the [Hand On] key on the LCP or by hand-on command of digital input.
[166]	Remote ref. active	The output is high when remote reference is activated by the [Auto On] key on the LCP or by auto-on command of digital input.
[167]	Start command activ	The output is high when there is an active start command (that is, via digital input bus connection or [Hand On] or [Auto On]), and no stop command is active.

[168]	Drive in hand mode	The output is high when the drive is in hand-on mode (as indicated by the LED light above [Hand On]).
[169]	Drive in auto mode	The output is high when the drive is in auto-on mode (as indicated by the LED light above [Auto On]).
[188]	AHF Capacitor Connect	Connect or disconnect AHF capacitor.
[190]	No-Flow	A no-flow condition has been detected. See <i>parameter group 22-2* No-Flow Detection</i> .
[191]	Dry Pump	A dry-pump condition has been detected. Enable the function in <i>parameter 22-26 Dry Pump Function</i> .
[192]	End Of Curve	An end-of-curve condition has been detected. Enable the function in <i>parameter 22-50 End of Curve Function</i> .
[193]	Sleep Mode	The drive/system has entered sleep mode. See <i>parameter group 22-4* Sleep Mode</i> .
[194]	Broken Belt Function	A broken-belt condition has been detected. Enable the function in <i>parameter 22-60 Broken Belt Function</i> .
[196]	Fire Mode	The drive is operating in fire mode. See <i>parameter group 24-0* Fire Mode</i> .
[198]	Drive Bypass	To be used as a signal for activating an external electromechanical bypass, switching the motor directly on line. See <i>parameter group 24-1* Drive Bypass</i> .
[200]	Full capacity	The drive enters full capacity mode.
[201]	Pump 1 running	Pump 1 is running.
[202]	Pump 2 running	Pump 2 is running.
[203]	Pump 3 running	Pump 3 is running.
[204]	Pump 4 running	Pump 4 is running.
[205]	Pump 5 running	Pump 5 is running.
[211]	Cascade Pump 1	Cascade pump 1 is running.
[212]	Cascade Pump 2	Cascade pump 2 is running.
[213]	Cascade Pump 3	Cascade pump 3 is running.
[214]	Cascade Pump 4	Cascade pump 4 is running.
[215]	Cascade Pump 5	Cascade pump 5 is running.

5-31 Terminal 29 Digital Output

Default value: [0] No operation	Parameter type: Option	2-setup: All setups
Conversion index: -	Data type: u_int8	Change during operation: True

Select the function for terminal 29 digital output.

Table 139: Option:

[0]	No operation	No operation.
[1]	Control Ready	The control board receives supply voltage.
[2]	Drive ready	The drive is ready for operation and applies a supply signal on the control board.

[3]	Drive ready/remote control	The drive is ready for operation in auto-on mode.
[4]	Standby/no warning	The drive is ready for operation. No start or stop command is given. No warnings are present.
[5]	Drive running	The motor runs.
[6]	Running/no warning	The motor runs, and no warnings are present.
[7]	Run in range/no warning	The motor runs within the programmed current ranges, see <i>parameter 4-50 Warning Current Low</i> and <i>parameter 4-51 Warning Current High</i> . No warnings are present.
[8]	Run on ref/no warning	The motor runs at reference speed and with no warnings.
[9]	Alarm	An alarm activates output.
[10]	Alarm or warning	An alarm or warning activates output.
[12]	Out of current range	The motor current is outside the ranges set in <i>parameter 4-50 Warning Current Low</i> and <i>parameter 4-51 Warning Current High</i> .
[13]	Below current, low	The motor current is lower than the limit set in <i>parameter 4-50 Warning Current Low</i> .
[14]	Above current, high	The motor current is higher than the limit set in <i>parameter 4-51 Warning Current High</i> .
[16]	Below speed, low	The drive output speed is lower than the limit set in <i>parameter 4-40 Warning Freq. Low</i> .
[17]	Above speed, high	The drive output speed is higher than the limit set in <i>parameter 4-41 Warning Freq. High</i> .
[19]	Below feedback, low	The feedback is lower than the limit set in <i>parameter 4-56 Warning Feedback Low</i> .
[20]	Above feedback, high	The feedback is higher than the limit set in <i>parameter 4-57 Warning Feedback High</i> .
[21]	Thermal warning	The thermal warning turns on when the temperature exceeds the limit in motor, drive, or thermistor.
[22]	Ready, no thermal warning	The drive is ready for operation and no thermal warning is present.
[23]	Remote, ready, no thermal warning	The drive is ready for operation in auto mode, and no thermal warning is present.
[24]	Ready, Voltage OK	The drive is ready for operation and mains voltage is within the specified voltage range.
[25]	Reverse	The motor runs/is ready to run clockwise when logic = 0 and counterclockwise when logic = 1. Output changes as soon as reversing signal is applied.
[26]	Bus OK	Active communication (no timeout) via serial communication port.
[35]	External Interlock	See [7] <i>External Interlock</i> in the <i>parameter group 5-1* Digital Input</i> .
[36]	Control word bit 11	Bit 11 in control word controls the relay.
[37]	Control word bit 12	Bit 12 in control word controls the relay.
[41]	Below reference, low	The reference is lower than the limit set in <i>parameter 4-54 Warning Reference Low</i> .
[42]	Above ref, high	The reference is higher than the limit set in <i>parameter 4-55 Warning Reference High</i> .
[45]	Bus Control	The output is configured in <i>parameter 5-90 Digital & Relay Bus Control</i> .
[60]	Comparator 0	See <i>parameter group 13-1* Comparators</i> . If comparator 0 is evaluated as true, the output goes high. Otherwise, it is low.

[61]	Comparator 1	See <i>parameter group 13-1* Comparators</i> . If comparator 1 is evaluated as true, the output goes high. Otherwise, it is low.
[62]	Comparator 2	See <i>parameter group 13-1* Comparators</i> . If comparator 2 is evaluated as true, the output goes high. Otherwise, it is low.
[63]	Comparator 3	See <i>parameter group 13-1* Comparators</i> . If comparator 3 is evaluated as true, the output goes high. Otherwise, it is low.
[64]	Comparator 4	See <i>parameter group 13-1* Comparators</i> . If comparator 4 is evaluated as true, the output goes high. Otherwise, it is low.
[65]	Comparator 5	See <i>parameter group 13-1* Comparators</i> . If comparator 5 is evaluated as true, the output goes high. Otherwise, it is low.
[70]	Logic rule 0	See <i>parameter group 13-4* Logic Rules</i> . If logic rule 0 is evaluated as true, the output goes high. Otherwise, it is low.
[71]	Logic rule 1	See <i>parameter group 13-4* Logic Rules</i> . If logic rule 1 is evaluated as true, the output goes high. Otherwise, it is low.
[72]	Logic rule 2	See <i>parameter group 13-4* Logic Rules</i> . If logic rule 2 is evaluated as true, the output goes high. Otherwise, it is low.
[73]	Logic rule 3	See <i>parameter group 13-4* Logic Rules</i> . If logic rule 3 is evaluated as true, the output goes high. Otherwise, it is low.
[74]	Logic rule 4	See <i>parameter group 13-4* Logic Rules</i> . If logic rule 4 is evaluated as true, the output goes high. Otherwise, it is low.
[75]	Logic rule 5	See <i>parameter group 13-4* Logic Rules</i> . If logic rule 5 is evaluated as true, the output goes high. Otherwise, it is low.
[80]	SL digital output A	See <i>parameter 13-52 SL Controller Action</i> . The input goes high whenever the smart logic action [38] <i>Set dig. out. A high</i> is executed. The input goes low whenever the smart logic [32] <i>Action Set dig. out. A low</i> is executed.
[81]	SL digital output B	See <i>parameter 13-52 SL Controller Action</i> . The input goes high whenever the smart logic action [39] <i>Set dig. out. B high</i> is executed. The input goes low whenever the smart logic [33] <i>Action Set dig. out. B low</i> is executed.
[82]	SL digital output C	See <i>parameter 13-52 SL Controller Action</i> . The input goes high whenever the smart logic action [40] <i>Set dig. out. C high</i> is executed. The input goes low whenever the smart logic [34] <i>Action Set dig. out. C low</i> is executed.
[83]	SL digital output D	See <i>parameter 13-52 SL Controller Action</i> . The input goes high whenever the smart logic action [41] <i>Set dig. out. D high</i> is executed. The input goes low whenever the smart logic [35] <i>Action Set dig. out. D low</i> is executed.
[160]	No alarm	The output is high when no alarm is present.
[161]	Running reverse	The output is high when the drive is running counterclockwise (the logical product of the status bits running and reverse).
[165]	Local ref. active	The output is high when local reference is activated by the [Hand On] key on the LCP or by hand-on command of digital input.
[166]	Remote ref. active	The output is high when remote reference is activated by the [Auto On] key on the LCP or by auto-on command of digital input.
[167]	Start command activ	The output is high when there is an active start command (that is, via digital input bus connection or [Hand On] or [Auto On]), and no stop command is active.

[168]	Drive in hand mode	The output is high when the drive is in hand-on mode (as indicated by the LED light above [Hand On]).
[169]	Drive in auto mode	The output is high when the drive is in auto-on mode (as indicated by the LED light above [Auto On]).
[188]	AHF Capacitor Connect	Connect or disconnect AHF capacitor.
[190]	No-Flow	A no-flow condition has been detected. See <i>parameter group 22-2* No-Flow Detection</i> .
[191]	Dry Pump	A dry-pump condition has been detected. Enable the function in <i>parameter 22-26 Dry Pump Function</i> .
[192]	End Of Curve	An end-of-curve condition has been detected. Enable the function in <i>parameter 22-50 End of Curve Function</i> .
[193]	Sleep Mode	The drive/system has entered sleep mode. See <i>parameter group 22-4* Sleep Mode</i> .
[194]	Broken Belt Function	A broken-belt condition has been detected. Enable the function in <i>parameter 22-60 Broken Belt Function</i> .
[196]	Fire Mode	The drive is operating in fire mode. See <i>parameter group 24-0* Fire Mode</i> .
[198]	Drive Bypass	To be used as a signal for activating an external electromechanical bypass, switching the motor directly on line. See <i>parameter group 24-1* Drive Bypass</i> .
[200]	Full capacity	The drive enters full capacity mode.
[201]	Pump 1 running	Pump 1 is running.
[202]	Pump 2 running	Pump 2 is running.
[203]	Pump 3 running	Pump 3 is running.
[204]	Pump 4 running	Pump 4 is running.
[205]	Pump 5 running	Pump 5 is running.
[211]	Cascade Pump 1	Cascade pump 1 is running.
[212]	Cascade Pump 2	Cascade pump 2 is running.
[213]	Cascade Pump 3	Cascade pump 3 is running.
[214]	Cascade Pump 4	Cascade pump 4 is running.
[215]	Cascade Pump 5	Cascade pump 5 is running.

5-34 On Delay, Digital Output

Default value: 0.01 s	Parameter type: Range	2-setup: All setups
Conversion index: -2	Data type: u_int16	Change during operation: True

Enter the delay time before the digital output is switched on. The digital output (terminal 42/45) condition must not be interrupted during the delay time.

Table 140: Range:

Min: 0 s	Max: 600 s	Default value: 0.01 s
----------	------------	-----------------------

5-35 Off Delay, Digital Output

Default value: 0.01 s	Parameter type: Range	2-setup: All setups
Conversion index: -2	Data type: u_int16	Change during operation: True

Enter the delay time before the digital output is switched off. The digital output (terminal 42/45) condition must not be interrupted during the delay time.

Table 141: Range:

Min: 0 s	Max: 600 s	Default value: 0.01 s
----------	------------	-----------------------

4.7.4 5-4* Relays

Parameters for configuring the timing and the output functions for the relays.

5-40 Function Relay

Default value: [0] No operation	Parameter type: Option	2-setup: All setups
Conversion index: -	Data type: u_int8	Change during operation: True

Select options to define the function of the relays.

Table 142: Option:

[0]	No operation	No operation.
[1]	Control Ready	The control board receives supply voltage.
[2]	Drive ready	The drive is ready for operation and applies a supply signal on the control board.
[3]	Drive ready/remote control	The drive is ready for operation in auto-on mode.
[4]	Standby/no warning	The drive is ready for operation. No start or stop command is given. No warnings are present.
[5]	Drive running	The motor runs.
[6]	Running/no warning	The motor runs, and no warnings are present.
[7]	Run in range/no warning	The motor runs within the programmed current ranges, see <i>parameter 4-50 Warning Current Low</i> and <i>parameter 4-51 Warning Current High</i> . No warnings are present.
[8]	Run on ref/no warning	The motor runs at reference speed and with no warnings.
[9]	Alarm	An alarm activates output.
[10]	Alarm or warning	An alarm or warning activates output.
[12]	Out of current range	The motor current is outside the ranges set in <i>parameter 4-50 Warning Current Low</i> and <i>parameter 4-51 Warning Current High</i> .
[13]	Below current, low	The motor current is lower than the limit set in <i>parameter 4-50 Warning Current Low</i> .
[14]	Above current, high	The motor current is higher than the limit set in <i>parameter 4-51 Warning Current High</i> .
[16]	Below speed, low	The drive output speed is lower than the limit set in <i>parameter 4-40 Warning Freq. Low</i> .
[17]	Above speed, high	The drive output speed is higher than the limit set in <i>parameter 4-41 Warning Freq. High</i> .
[19]	Below feedback, low	The feedback is lower than the limit set in <i>parameter 4-56 Warning Feedback Low</i> .
[20]	Above feedback, high	The feedback is higher than the limit set in <i>parameter 4-57 Warning Feedback High</i> .

[21]	Thermal warning	The thermal warning turns on when the temperature exceeds the limit in motor, drive, or thermistor.
[22]	Ready, no thermal warning	The drive is ready for operation and no thermal warning is present.
[23]	Remote, ready, no thermal warning	The drive is ready for operation in auto-on mode, and no thermal warning is present.
[24]	Ready, Voltage OK	The drive is ready for operation and mains voltage is within the specified voltage range.
[25]	Reverse	The motor runs/is ready to run clockwise when logic = 0 and counterclockwise when logic = 1. Output changes as soon as reversing signal is applied.
[26]	Bus OK	Active communication (no timeout) via serial communication port.
[35]	External Interlock	See digital input.
[36]	Control word bit 11	Bit 11 in control word controls the relay.
[37]	Control word bit 12	Bit 12 in control word controls the relay.
[41]	Below reference, low	The reference is lower than the limit set in <i>parameter 4-54 Warning Reference Low</i> .
[42]	Above ref, high	The reference is higher than the limit set in <i>parameter 4-55 Warning Reference High</i> .
[45]	Bus Control	The output is configured in <i>parameter 5-90 Digital & Relay Bus Control</i> .
[60]	Comparator 0	See <i>parameter group 13-1* Comparators</i> . If comparator 0 is evaluated as true, the output goes high. Otherwise, it is low.
[61]	Comparator 1	See <i>parameter group 13-1* Comparators</i> . If comparator 1 is evaluated as true, the output goes high. Otherwise, it is low.
[62]	Comparator 2	See <i>parameter group 13-1* Comparators</i> . If comparator 2 is evaluated as true, the output goes high. Otherwise, it is low.
[63]	Comparator 3	See <i>parameter group 13-1* Comparators</i> . If comparator 3 is evaluated as true, the output goes high. Otherwise, it is low.
[64]	Comparator 4	See <i>parameter group 13-1* Comparators</i> . If comparator 4 is evaluated as true, the output goes high. Otherwise, it is low.
[65]	Comparator 5	See <i>parameter group 13-1* Comparators</i> . If comparator 5 is evaluated as true, the output goes high. Otherwise, it is low.
[70]	Logic rule 0	See <i>parameter group 13-4* Logic Rules</i> . If logic rule 0 is evaluated as true, the output goes high. Otherwise, it is low.
[71]	Logic rule 1	See <i>parameter group 13-4* Logic Rules</i> . If logic rule 1 is evaluated as true, the output goes high. Otherwise, it is low.
[72]	Logic rule 2	See <i>parameter group 13-4* Logic Rules</i> . If logic rule 2 is evaluated as true, the output goes high. Otherwise, it is low.
[73]	Logic rule 3	See <i>parameter group 13-4* Logic Rules</i> . If logic rule 3 is evaluated as true, the output goes high. Otherwise, it is low.
[74]	Logic rule 4	See <i>parameter group 13-4* Logic Rules</i> . If logic rule 4 is evaluated as true, the output goes high. Otherwise, it is low.
[75]	Logic rule 5	See <i>parameter group 13-4* Logic Rules</i> . If logic rule 5 is evaluated as true, the output goes high. Otherwise, it is low.

[80]	SL digital output A	See <i>parameter 13-52 SL Controller Action</i> . The input goes high whenever the smart logic action [38] <i>Set dig. out. A high</i> is executed. The input goes low whenever the smart logic [32] <i>Action Set dig. out. A low</i> is executed.
[81]	SL digital output B	See <i>parameter 13-52 SL Controller Action</i> . The input goes high whenever the smart logic action [39] <i>Set dig. out. B high</i> is executed. The input goes low whenever the smart logic [33] <i>Action Set dig. out. B low</i> is executed.
[82]	SL digital output C	See <i>parameter 13-52 SL Controller Action</i> . The input goes high whenever the smart logic action [40] <i>Set dig. out. C high</i> is executed. The input goes low whenever the smart logic [34] <i>Action Set dig. out. C low</i> is executed.
[83]	SL digital output D	See <i>parameter 13-52 SL Controller Action</i> . The input goes high whenever the smart logic action [41] <i>Set dig. out. D high</i> is executed. The input goes low whenever the smart logic [35] <i>Action Set dig. out. D low</i> is executed.
[97]	Check Valve Monitor	A check valve monitor condition has been detected. Enable the function in <i>parameter 22-04 Check Valve Monitor</i> .
[160]	No alarm	The output is high when no alarm is present.
[161]	Running reverse	The output is high when the drive is running counterclockwise (the logical product of the status bits running and reverse).
[165]	Local ref. active	The output is high when local reference is activated by the [Hand On] key on the LCP or by hand-on command of digital input.
[166]	Remote ref. active	The output is high when remote reference is activated by the [Auto On] key on the LCP or by auto-on command of digital input.
[167]	Start command activ	The output is high when there is an active start command (that is, via digital input bus connection or [Hand On] or [Auto On]), and no stop command is active.
[168]	Drive in hand mode	The output is high when the drive is in hand-on mode (as indicated by the LED light above [Hand On]).
[169]	Drive in auto mode	The output is high when the drive is in auto-on mode (as indicated by the LED light above [Auto On]).
[188]	AHF Capacitor Connect	Connect or disconnect AHF capacitor.
[190]	No-Flow	A no-flow condition has been detected. See <i>parameter group 22-2* No-Flow Detection</i> .
[191]	Dry Pump	A dry-pump condition has been detected. Enable the function in <i>parameter 22-26 Dry Pump Function</i> .
[192]	End Of Curve	An end-of-curve condition has been detected. Enable the function in <i>parameter 22-50 End of Curve Function</i> .
[193]	Sleep Mode	The drive/system has entered sleep mode. See <i>parameter group 22-4* Sleep Mode</i> .
[194]	Broken Belt Function	A broken-belt condition has been detected. Enable the function in <i>parameter 22-60 Broken Belt Function</i> .
[196]	Fire Mode	The drive is operating in fire mode. See <i>parameter group 24-0* Fire Mode</i> .
[198]	Drive Bypass	To be used as a signal for activating an external electromechanical bypass, switching the motor directly on line. See <i>parameter group 24-1* Drive Bypass</i> .
[211]	Cascade Pump 1	Cascade pump 1 is running.
[212]	Cascade Pump 2	Cascade pump 2 is running.

[213]	Cascade Pump 3	Cascade pump 3 is running.
[214]	Cascade Pump 4	Cascade pump 4 is running.
[215]	Cascade Pump 5	Cascade pump 5 is running.

5-41 On Delay, Relay

Default value: 0.01 s	Parameter type: Range	2-setup: All setups
Conversion index: -2	Data type: u_int16	Change during operation: True

Enter the delay of the relay cut-in time. Select 1 of 2 internal mechanical relays in an array function. See *parameter 5-40 Function Relay* for details.

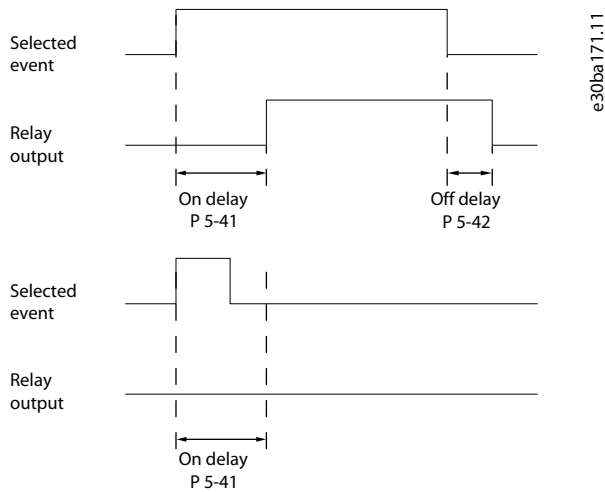

Illustration 12: On Delay, Relay

If the selected event condition changes before the on delay timer expires, the relay output is unaffected.

Table 143: Range:

Min: 0 s	Max: 600 s	Default value: 0.01 s
----------	------------	-----------------------

5-42 Off Delay, Relay

Default value: 0.01 s	Parameter type: Range	2-setup: All setups
Conversion index: -2	Data type: u_int16	Change during operation: True

Enter the delay of the relay cutout time. Select 1 of 2 internal mechanical relays in an array function. See *parameter 5-40 Function Relay* for details. If the selected event condition changes before a delay timer expires, the relay output is unaffected.

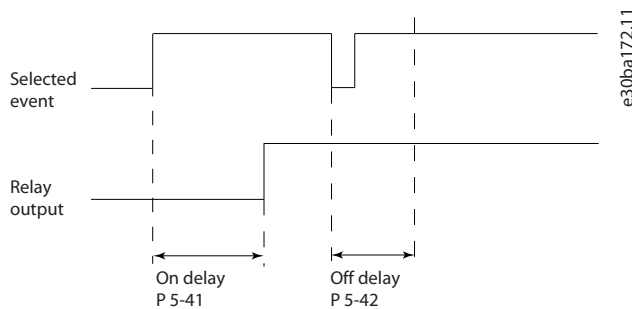

Illustration 13: Off Delay, Relay

If the selected event condition changes before the off delay timer expires, the relay output is unaffected.

Table 144: Range:

Min: 0 s	Max: 600 s	Default value: 0.01 s
----------	------------	-----------------------

4.7.5 5-5* Pulse Input

The pulse input parameters are used to define an appropriate window for the impulse reference area by configuring the scaling and filter settings for the pulse inputs. Input terminals 29 act as frequency reference inputs. Set terminal 29 (*parameter 5-13 Terminal 29 Digital Input*) to [32] *Pulse input*. If terminal 29 is used as an input, set *parameter 5-02 Terminal 29 Mode* to [0] *Input*.

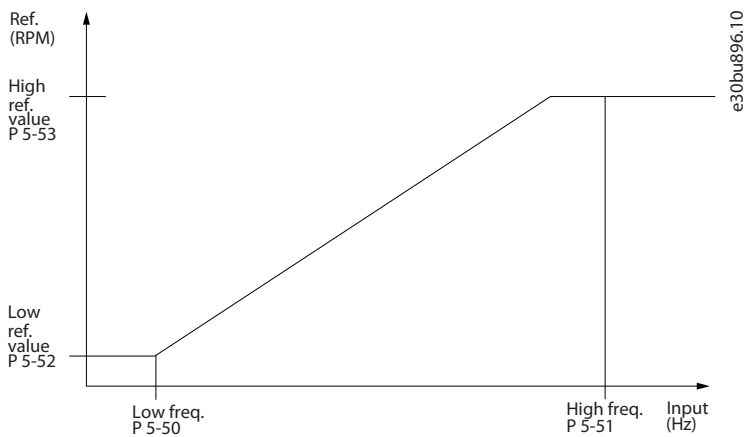

Illustration 14: Pulse Input

5-50 Term. 29 Low Frequency

Default value: 20 Hz	Parameter type: Range	2-setup: All setups
Conversion index: -	Data type: u_int32	Change during operation: True

Enter the low frequency limit corresponding to the low motor shaft speed (that is low reference value) in *parameter 5-52 Term. 29 Low Ref./Feedb. Value*.

Table 145: Range:

Min: 20 Hz	Max: 31999 Hz	Default value: 20 Hz
------------	---------------	----------------------

5-51 Term. 29 High Frequency

Default value: 32000 Hz	Parameter type: Range	2-setup: All setups
Conversion index: -	Data type: u_int32	Change during operation: True

Enter the high frequency limit corresponding to the high motor shaft speed (that is high reference value) in *parameter 5-53 Term. 29 High Ref./Feedb. Value*.

Table 146: Range:

Min: 21 Hz	Max: 32000 Hz	Default value: 32000 Hz
------------	---------------	-------------------------

5-52 Term. 29 Low Ref./Feedb. Value

Default value: 0	Parameter type: Range	2-setup: All setups
Conversion index: -3	Data type: int32	Change during operation: True

Enter the reference or feedback value (in for example, RPM, Hz, bar) that corresponds to the pulse frequency set in *parameter 5-50 Term. 29 Low Frequency*.

Table 147: Range:

Min: -4999	Max: 4999	Default value: 0
------------	-----------	------------------

5-53 Term. 29 High Ref./Feedb. Value

Default value: Configuration dependent	Parameter type: Range	2-setup: All setups
Conversion index: -3	Data type: int32	Change during operation: True

Enter the reference or feedback value (in for example, RPM, Hz, bar) that corresponds to the pulse frequency set in *parameter 5-51 Term. 29 High Frequency*.

Table 148: Range:

Min: -4999	Max: 4999	Default value: Configuration dependent
------------	-----------	--

4.7.6 5-8* I/O Options

5-80 AHF Cap Reconnect Delay

Default value: 25 s	Parameter type: Range	2-setup: All setups
Conversion index: 0	Data type: u_int16	Change during operation: True

Delay time between 2 consecutive AHF capacitor connections. Timer starts once the AHF capacitor disconnect and connects back once the delay expires and the drive power is above 20% and below 30% of nominal power.

Table 149: Range:

Min: 1 s	Max: 120 s	Default value: 25 s
----------	------------	---------------------

4.7.7 5-9* Bus Controlled

This parameter group selects digital and relay outputs via a fieldbus setting.

5-90 Digital & Relay Bus Control

Default value: 0	Parameter type: Range	2-setup: All setups
Conversion index: 0	Data type: u_int32	Change during operation: True

This parameter holds the state of the buscontrolled digital outputs and relays. A logical 1 indicates that the output is high or active. A logical 0 indicates that the output is low or inactive.

Table 150: Range:

Min: 0	Max: 4294967295	Default value: 0
--------	-----------------	------------------

4.8 Parameter Group 6-** Analog In/Out

Parameter group for setting up the analog I/O configuration and the digital output.

The drive provides 2 analog inputs:

- Terminal 53.
- Terminal 54.

The analog inputs can be freely allocated to either voltage (0–10 V) or current input (0/4–20 mA).

4.8.1 6-0* Analog I/O Mode

6-00 Live Zero Timeout Time

Default value: 10 s	Parameter type: Range	2-setup: All setups
Conversion index: 0	Data type: u_int8	Change during operation: True

Enter the timeout time.

Table 151: Range:

Min: 1 s	Max: 99 s	Default value: 10 s
----------	-----------	---------------------

6-01 Live Zero Timeout Function

Default value: [0] Off	Parameter type: Option	2-setup: All setups
Conversion index: -	Data type: u_int8	Change during operation: True

Select the timeout function. The function set in *parameter 6-01 Live Zero Timeout Function* is activated if the input signal on terminal 53 or 54 is below 50% of the value in *parameter 6-10 Terminal 53 Low Voltage*, *parameter 6-12 Terminal 53 Low Current*, *parameter 6-20 Terminal 54 Low Voltage*, or *parameter 6-22 Terminal 54 Low Current* for a time period defined in *parameter 6-00 Live Zero Timeout Time*.

Table 152: Option:

[0]	Off
[1]	Freeze output
[2]	Stop
[3]	Jogging
[4]	Max. speed
[5]	Stop and trip

6-02 Fire Mode Live Zero Timeout Function

Default value: [0] Off	Parameter type: Option	2-setup: All setups
Conversion index: -	Data type: u_int8	Change during operation: True

Select the timeout function when the fire mode is active. The function set in this parameter is activated if the input signal on analog inputs is below 50% of the low value for a time period defined in *parameter 6-00 Live Zero Timeout Time*.

Table 153: Option:

[0]	Off
[1]	Freeze output
[2]	Stop
[3]	Jogging
[4]	Max. speed

4.8.2 6-1* Analog Input 53

Parameters for configuring the scaling and limits for analog input 53 (terminal 53).

6-10 Terminal 53 Low Voltage

Default value: 0.07 V	Parameter type: Range	2-setup: All setups
Conversion index: -2	Data type: u_int16	Change during operation: True

Enter the voltage (V) that corresponds to *parameter 6-14 Terminal 53 Low Ref./Feedb. Value*. To activate *parameter 6-01 Live Zero Timeout Function*, set the value to >1 V.

Table 154: Range:

Min: 0 V	Max: 10 V	Default value: 0.07 V
----------	-----------	-----------------------

6-11 Terminal 53 High Voltage

Default value: 10 V	Parameter type: Range	2-setup: All setups
Conversion index: -2	Data type: u_int16	Change during operation: True

Enter the voltage (V) that corresponds to the high reference value (set in *parameter 6-15 Terminal 53 High Ref./Feedb. Value*).

Table 155: Range:

Min: 0 V	Max: 10 V	Default value: 10 V
----------	-----------	---------------------

6-12 Terminal 53 Low Current

Default value: 4 mA	Parameter type: Range	2-setup: All setups
Conversion index: -2	Data type: u_int16	Change during operation: True

Enter the low current value. This reference signal corresponds to the low reference/feedback value that is set in *parameter 6-14 Terminal 53 Low Ref./Feedb. Value*. To activate *parameter 6-01 Live Zero Timeout Function*, set the value to >2 mA.

Table 156: Range:

Min: 0 mA	Max: 20 mA	Default value: 4 mA
-----------	------------	---------------------

6-13 Terminal 53 High Current

Default value: 20 mA	Parameter type: Range	2-setup: All setups
Conversion index: -2	Data type: u_int16	Change during operation: True

Enter the high current value corresponding to the high reference/feedback set in *parameter 6-15 Terminal 53 High Ref./Feedb. Value*.

Table 157: Range:

Min: 0 mA	Max: 20 mA	Default value: 20 mA
-----------	------------	----------------------

6-14 Terminal 53 Low Ref./Feedb. Value

Default value: 0	Parameter type: Range	2-setup: All setups
Conversion index: -3	Data type: int32	Change during operation: True

Enter the reference or feedback value that corresponds to the voltage or current set in *parameter 6-10 Terminal 53 Low Voltage* to *parameter 6-12 Terminal 53 Low Current*.

Table 158: Range:

Min: -4999	Max: 4999	Default value: 0
------------	-----------	------------------

6-15 Terminal 53 High Ref./Feedb. Value

Default value: Configuration dependent	Parameter type: Range	2-setup: All setups
Conversion index: -3	Data type: int32	Change during operation: True

Enter the reference or feedback value that corresponds to the voltage or current set in *parameter 6-11 Terminal 53 High Voltage* to *parameter 6-13 Terminal 53 High Current*.

Table 159: Range:

Min: -4999	Max: 4999	Default value: Configuration dependent
------------	-----------	--

6-16 Terminal 53 Filter Time Constant

Default value: 0.01 s	Parameter type: Range	2-setup: All setups
Conversion index: -2	Data type: u_int16	Change during operation: True

Enter the time constant. This constant is a first-order digital low-pass filter time constant for suppressing electrical noise in terminal 53. A high time constant value improves dampening, but also increases the time delay through the filter.

Table 160: Range:

Min: 0.01 s	Max: 10 s	Default value: 0.01 s
-------------	-----------	-----------------------

6-19 Terminal 53 mode

Default value: [1] Voltage mode	Parameter type: Option	2-setup: 1 setup
Conversion index: -	Data type: u_int8	Change during operation: True

Select whether terminal 53 is used for current or voltage input.

Table 161: Option:

[0]	Current mode
[1]	Voltage mode

4.8.3 6-2* Analog Input 54

Parameters for configuring the scaling and limits for analog input 54 (terminal 54).

6-20 Terminal 54 Low Voltage

Default value: 0.07 V	Parameter type: Range	2-setup: All setups
Conversion index: -2	Data type: u_int16	Change during operation: True

Enter the voltage (V) that corresponds to *parameter 6-24 Terminal 54 Low Ref./Feedb. Value*. To activate *parameter 6-01 Live Zero Timeout Function*, set the value to >1 V.

Table 162: Range:

Min: 0 V	Max: 10 V	Default value: 0.07 V
----------	-----------	-----------------------

6-21 Terminal 54 High Voltage

Default value: 10 V	Parameter type: Range	2-setup: All setups
Conversion index: -2	Data type: u_int16	Change during operation: True

Enter the voltage (V) that corresponds to the high reference value (set in *parameter 6-25 Terminal 54 High Ref./Feedb. Value*).

Table 163: Range:

Min: 0 V	Max: 10 V	Default value: 10 V
----------	-----------	---------------------

6-22 Terminal 54 Low Current

Default value: 4 mA	Parameter type: Range	2-setup: All setups
Conversion index: -2	Data type: u_int16	Change during operation: True

Enter the low current value. This reference signal corresponds to the low reference/ feedback value that is set in *parameter 6-24 Terminal 54 Low Ref./Feedb. Value*. To activate *parameter 6-01 Live Zero Timeout Function*, set the value to >2 mA.

Table 164: Range:

Min: 0 mA	Max: 20 mA	Default value: 4 mA
-----------	------------	---------------------

6-23 Terminal 54 High Current

Default value: 20 mA	Parameter type: Range	2-setup: All setups
Conversion index: -2	Data type: u_int16	Change during operation: True

Enter the high current value corresponding to the high reference/feedback set in *parameter 6-25 Terminal 54 High Ref./Feedb. Value*.

Table 165: Range:

Min: 0 mA	Max: 20 mA	Default value: 20 mA
-----------	------------	----------------------

6-24 Terminal 54 Low Ref./Feedb. Value

Default value: 0	Parameter type: Range	2-setup: All setups
Conversion index: -3	Data type: int32	Change during operation: True

Enter the reference or feedback value that corresponds to the voltage or current set in *parameter 6-20 Terminal 54 Low Voltage* to *parameter 6-22 Terminal 54 Low Current*.

Table 166: Range:

Min: -4999	Max: 4999	Default value: 0
------------	-----------	------------------

6-25 Terminal 54 High Ref./Feedb. Value

Default value: Configuration dependent	Parameter type: Range	2-setup: All setups
Conversion index: -3	Data type: int32	Change during operation: True

Enter the reference or feedback value that corresponds to the voltage or current set in *parameter 6-21 Terminal 53 High Voltage* to *parameter 6-23 Terminal 53 High Current*.

Table 167: Range:

Min: -4999	Max: 4999	Default value: Configuration dependent
------------	-----------	--

6-26 Terminal 54 Filter Time Constant

Default value: 0.01 s	Parameter type: Range	2-setup: All setups
Conversion index: -2	Data type: u_int16	Change during operation: True

Enter the time constant. This constant is a first-order digital low-pass filter time constant for suppressing electrical noise in terminal 54. A high time constant value improves dampening, but also increases the time delay through the filter.

Table 168: Range:

Min: 0.01 s	Max: 10 s	Default value: 0.01 s
-------------	-----------	-----------------------

6-29 Terminal 54 mode

Default value: [1] Voltage mode	Parameter type: Option	2-setup: 1 setup
Conversion index: -	Data type: u_int8	Change during operation: True

Select whether terminal 54 is used for current or voltage input.

Table 169: Option:

[0]	Current mode
[1]	Voltage mode

4.8.4 6-7* Analog/Digital Output 45

Parameters for configuring the scaling and limits for analog/digital output terminal 45. Analog outputs are current outputs: 0/4–20 mA. Resolution on analog output is 12 bit. Analog output terminals can also be set up as digital output.

6-70 Terminal 45 Mode

Default value: [0] 0-20 mA	Parameter type: Option	2-setup: All setups
Conversion index: -	Data type: u_int8	Change during operation: True

Set terminal 45 to act as analog output or as digital output.

Table 170: Option:

[0]	0-20 mA
[1]	4-20 mA
[2]	Digital Output

6-71 Terminal 45 Analog Output

Default value: [0] No operation	Parameter type: Option	2-setup: All setups
Conversion index: -	Data type: u_int8	Change during operation: True

Select the function of terminal 45 as an analog current output. See also *parameter 6-70 Terminal 45 Mode*.

Table 171: Option:

[0]	No operation
[100]	Output frequency
[101]	Reference
[102]	Feedback
[103]	Motor Current
[106]	Power
[139]	Bus Control
[254]	DC Link Voltage

6-72 Terminal 45 Digital Output

Default value: [0] No operation	Parameter type: Option	2-setup: All setups
Conversion index: -	Data type: u_int8	Change during operation: True

Select the function of terminal 45 as a digital current output. See also *parameter 6-70 Terminal 45 Mode*. See *parameter 5-40 Function Relay* for description of the options.

Table 172: Option:

[0]	No operation
[1]	Control Ready

[2]	Drive ready
[3]	Drive ready/remote control
[4]	Standby/no warning
[5]	Drive running
[6]	Running/no warning
[7]	Run in range/no warning
[8]	Run on ref/no warning
[9]	Alarm
[10]	Alarm or warning
[12]	Out of current range
[13]	Below current, low
[14]	Above current, high
[16]	Below speed, low
[17]	Above speed, high
[19]	Below feedback, low
[20]	Above feedback, high
[21]	Thermal warning
[22]	Ready, no thermal warning
[23]	Remote, ready, no thermal warning
[24]	Ready, Voltage OK
[25]	Reverse
[26]	Bus OK
[35]	External Interlock
[36]	Control word bit 11
[37]	Control word bit 12
[41]	Below reference, low
[42]	Above ref, high
[45]	Bus control
[60]	Comparator 0
[61]	Comparator 1
[62]	Comparator 2
[63]	Comparator 3
[64]	Comparator 4

[65]	Comparator 5
[70]	Logic rule 0
[71]	Logic rule 1
[72]	Logic rule 2
[73]	Logic rule 3
[74]	Logic rule 4
[75]	Logic rule 5
[80]	SL digital output A
[81]	SL digital output B
[82]	SL digital output C
[83]	SL digital output D
[97]	Check valve monitor
[160]	No alarm
[161]	Running reverse
[165]	Local ref. active
[166]	Remote ref. active
[167]	Start command activ
[168]	Drive in hand mode
[169]	Drive in auto mode
[188]	AHF capacitor connect
[190]	No-flow
[191]	Dry pump
[192]	End of curve
[193]	Sleep mode
[194]	Broken belt function
[196]	Fire mode
[198]	Drive bypass
[200]	Full capacity
[201]	Pump 1 running
[202]	Pump 2 running
[203]	Pump 3 running
[204]	Pump 4 running
[205]	Pump 5 running

[211]	Cascade pump 1
[212]	Cascade pump 2
[213]	Cascade pump 3
[214]	Cascade pump 4
[215]	Cascade pump 5

6-73 Terminal 45 Output Min Scale

Default value: 0%	Parameter type: Range	2-setup: All setups
Conversion index: -2	Data type: u_int16	Change during operation: True

Scale for the minimum output (0 mA or 4 mA) of the analog signal at terminal 45. Set the value to be the percentage of the full range of the variable selected in *parameter 6-71 Terminal 45 Analog Output*.

Table 173: Range:

Min: 0%	Max: 200%	Default value: 0%
---------	-----------	-------------------

6-74 Terminal 45 Output Max Scale

Default value: 100%	Parameter type: Range	2-setup: All setups
Conversion index: -2	Data type: u_int16	Change during operation: True

Scale for the maximum output (20 mA) of the analog signal at terminal 45. Set the value to be the percentage of the full range of the variable selected in *parameter 6-71 Terminal 45 Analog Output*.

Table 174: Range:

Min: 0%	Max: 200%	Default value: 100%
---------	-----------	---------------------

6-76 Terminal 45 Output Bus Control

Default value: 0	Parameter type: Range	2-setup: All setups
Conversion index: 0	Data type: u_int16	Change during operation: True

Holds the level of analog output if controlled by bus.

Table 175: Range:

Min: 0	Max: 16384	Default value: 0
--------	------------	------------------

4.8.5 6-9* Analog/Digital Output 42

Parameters for configuring the limits for analog/digital output terminal 42. Analog outputs are current outputs: 0/4–20 mA. Resolution on analog outputs is 12 bit. Analog output terminals can also be set up as digital output.

6-90 Terminal 42 Mode

Default value: [0] 0–20 mA	Parameter type: Option	2-setup: All setups
Conversion index: -	Data type: u_int8	Change during operation: True

Set terminal 45 to act as analog output or as digital output.

Table 176: Option:

[0]	0-20 mA
[1]	4-20 mA
[2]	Digital Output

6-91 Terminal 42 Analog Output

Default value: [0] No operation	Parameter type: Option	2-setup: All setups
Conversion index: -	Data type: u_int8	Change during operation: True

Select the function of terminal 42 as an analog current output. See also *parameter 6-90 Terminal 42 Mode*.

Table 177: Option:

[0]	No operation
[100]	Output frequency
[101]	Reference
[102]	Feedback
[103]	Motor current
[106]	Power
[139]	Bus control
[184]	Mirror AI53 mA
[185]	Mirror AI54 mA
[254]	DC link voltage

6-92 Terminal 42 Digital Output

Default value: [0] No operation	Parameter type: Option	2-setup: All setups
Conversion index: -	Data type: u_int8	Change during operation: True

Select the function of terminal 42 as a digital current output. See also *parameter 6-90 Terminal 42 Mode*. See *parameter 5-40 Function Relay* for description of the options.

Table 178: Option:

[0]	No operation
[1]	Control ready
[2]	Drive ready
[3]	Drive ready/remote control
[4]	Standby/no warning
[5]	Drive running
[6]	Running/no warning
[7]	Run in range/no warning
[8]	Run on ref/no warning

[9]	Alarm
[10]	Alarm or warning
[12]	Out of current range
[13]	Below current, low
[14]	Above current, high
[16]	Below speed, low
[17]	Above speed, high
[19]	Below feedback, low
[20]	Above feedback, high
[21]	Thermal warning
[22]	Ready, no thermal warning
[23]	Remote, ready, no thermal warning
[24]	Ready, voltage OK
[25]	Reverse
[26]	Bus OK
[35]	External interlock
[36]	Control word bit 11
[37]	Control word bit 12
[41]	Below reference, low
[42]	Above ref, high
[45]	Bus control
[60]	Comparator 0
[61]	Comparator 1
[62]	Comparator 2
[63]	Comparator 3
[64]	Comparator 4
[65]	Comparator 5
[70]	Logic rule 0
[71]	Logic rule 1
[72]	Logic rule 2
[73]	Logic rule 3
[74]	Logic rule 4
[75]	Logic rule 5

[80]	SL digital output A
[81]	SL digital output B
[82]	SL digital output C
[83]	SL digital output D
[97]	Check valve monitor
[160]	No alarm
[161]	Running reverse
[165]	Local ref. active
[166]	Remote ref. active
[167]	Start command activ
[168]	Drive in hand mode
[169]	Drive in auto mode
[188]	AHF capacitor connect
[190]	No flow
[191]	Dry pump
[192]	End of curve
[193]	Sleep mode
[194]	Broken belt function
[196]	Fire mode
[198]	Drive bypass
[200]	Full capacity
[201]	Pump 1 running
[202]	Pump 2 running
[203]	Pump 3 running
[204]	Pump 4 running
[205]	Pump 5 running
[211]	Cascade pump 1
[212]	Cascade pump 2
[213]	Cascade pump 3
[214]	Cascade pump 4
[215]	Cascade pump 5

6-93 Terminal 42 Output Min Scale

Default value: 0%	Parameter type: Range	2-setup: All setups
Conversion index: -2	Data type: u_int16	Change during operation: True

Scale for the minimum output (0 mA or 4 mA) of the analog signal at terminal 42. Set the value to be the percentage of the full range of the variable selected in *parameter 6-91 Terminal 42 Analog Output*.

Table 179: Range:

Min: 0%	Max: 200%	Default value: 0%
---------	-----------	-------------------

6-94 Terminal 42 Output Max Scale

Default value: 100%	Parameter type: Range	2-setup: All setups
Conversion index: -2	Data type: u_int16	Change during operation: True

Scale for the maximum output (20 mA) of the analog signal at terminal 42. Set the value to be the percentage of the full range of the variable selected in *parameter 6-91 Terminal 42 Analog Output*.

Table 180: Range:

Min: 0%	Max: 200%	Default value: 100%
---------	-----------	---------------------

6-96 Terminal 42 Output Bus Control

Default value: 0	Parameter type: Range	2-setup: All setups
Conversion index: 0	Data type: u_int16	Change during operation: True

Holds the level of analog output if controlled by bus.

Table 181: Range:

Min: 0	Max: 16384	Default value: 0
--------	------------	------------------

6-98 Drive Type

Default value: 0	Parameter type: Range	2-setup: 1 setup
Conversion index: 0	Data type: u_int8	Change during operation: False

Table 182: Range:

Min: 0	Max: 0	Default value: 0
--------	--------	------------------

4.9 Parameter Group 8-** Comm. and Options

4.9.1 8-0* General Settings

8-01 Control Site

Default value: [0] Digital and ctrl.word	Parameter type: Option	2-setup: All setups
Conversion index: -	Data type: u_int8	Change during operation: True

This parameter overrules settings in *parameter 8-50 Coasting Select* to *parameter 8-56 Preset Reference Select*.

Table 183: Option:

[0]	Digital and ctrl.word	Control by using both digital input and control word.
[1]	Digital only	Control by using digital inputs only.
[2]	Controlword only	Control by using control word only.

8-02 Control Source

Default value: [1] None	Parameter type: Option	2-setup: All setups
Conversion index: -	Data type: u_int8	Change during operation: True

Select the source of the control word.

Table 184: Option:

[0]	None
[1]	FC Port

8-03 Control Timeout Time

Default value: Configuration dependent	Parameter type: Range	2-setup: 1 setup
Conversion index: -1	Data type: u_int16	Change during operation: True

Enter the maximum time expected to pass between the reception of 2 consecutive telegrams. If this time is exceeded, it indicates that the serial communication has stopped. The function selected in *parameter 8-04 Control Timeout Function* is carried out.

Table 185: Range:

Min: 0.1 s	Max: 6500 s	Default value: Configuration dependent
------------	-------------	--

8-04 Control Timeout Function

Default value: [0] Off	Parameter type: Option	2-setup: 1 setup
Conversion index: -	Data type: u_int8	Change during operation: True

Select the timeout function. The timeout function is activated when the control word fails to be updated within the time period specified in *parameter 8-03 Control Timeout Time*.

Table 186: Option:

[0]	Off
[1]	Freeze output
[2]	Stop
[3]	Jogging
[4]	Max. speed
[5]	Stop and trip
[6]	Qstop and trip
[20]	N2 override release
[26]	Trip

4.9.2 8-3* FC Port Settings

8-30 Protocol

Default value: [0] FC	Parameter type: Option	2-setup: 1 setup
Conversion index: -	Data type: u_int8	Change during operation: True

Select the protocol for the integrated RS485 port.

Table 187: Option:

[0]	FC	Communication according to the FC Protocol.
[2]	Modbus RTU	Communication according to the Modbus RTU protocol.
[3]	Metasys N2	Communication protocol. The N2 software protocol is designed to be general in nature to accommodate the unique properties each device may have.
[4]	FLN	Communication according to the FLN protocol.
[5]	BACnet	Communication according to the BACNet protocol.
[20]	LEN	Communication according to the LEN protocol.
[24]	Vertiv MB Converter	Communication according to the Vertiv MB Converter protocol.

8-31 Address

Default value: Configuration dependent	Parameter type: Range	2-setup: 1 setup
Conversion index: -	Data type: u_int8	Change during operation: True

Enter the address for the RS485 port. Valid range: 1–126 for FC-bus OR 1– 247 for Modbus.

Table 188: Range:

Min: 0.0	Max: 247	Default value: Configuration dependent
----------	----------	--

8-32 Baud Rate

Default value: -	Parameter type: Option	2-setup: 1 setup
Conversion index: -	Data type: u_int8	Change during operation: True

Select the baud rate for the RS485 port. Default value refers to the FC protocol. Changing the protocol in *parameter 8-30 Protocol* may change the baud rate.

Table 189: Option:

[0]	2400 Baud	-
[1]	4800 Baud	Default setting for FLN.
[2]	9600 Baud	Default setting for: <ul style="list-style-type: none"> • BACnet. • Metasys N2.
[3]	19200 Baud	Default setting for Modbus RTU.
[4]	38400 Baud	-

[5]	57600 Baud	-
[6]	76800 Baud	-
[7]	115200 Baud	-

8-33 Parity / Stop Bits

Default value: [0] Even parity, 1 stop bit	Parameter type: Option	2-setup: 1 setup
Conversion index: -	Data type: u_int8	Change during operation: True

Parity and stop bits for the protocol using the FC port. For some of the protocols, not all options are available. Default value refers to the FC protocol. Changing the protocol in *parameter 8-30 Protocol* may change the baud rate.

Table 190: Option:

[0]	Even parity, 1 stop bit
[1]	Odd parity, 1 stop bit
[2]	No parity, 1 stop bit
[3]	No parity, 2 stop bits

8-35 Minimum Response Delay

Default value: Configuration dependent	Parameter type: Range	2-setup: 1 setup
Conversion index: -3	Data type: u_int16	Change during operation: True

Specify the minimum delay time between receiving a request and transmitting a response. This is used for overcoming modem turnaround delays.

Table 191: Range:

Min: 0.0010 s	Max: 0.5 s	Default value: Configuration dependent
---------------	------------	--

8-36 Maximum Response Delay

Default value: Configuration dependent	Parameter type: Range	2-setup: 1 setup
Conversion index: -3	Data type: u_int16	Change during operation: True

Specify the maximum allowed delay time between receiving a request and transmitting the response. If this time is exceeded, no response is returned.

Table 192: Range:

Min: 0.1 s	Max: 10.0 s	Default value: Configuration dependent
------------	-------------	--

8-37 Maximum Inter-char delay

Default value: Configuration dependent	Parameter type: Range	2-setup: 1 setup
Conversion index: -3	Data type: u_int16	Change during operation: True

Specify the maximum delay time between 2 characters in a message. Exceeding this delay time causes the message to be discarded.

Table 193: Range:

Min: 0.005 s	Max: 0.025 s	Default value: Configuration dependent
--------------	--------------	--

4.9.3 8-4* FC MC Protocol Set

This parameter group is for PCD write and read configurations.

8-42 PCD Write Configuration

Default value: [0] None	Parameter type: Option	2-setup: All setups
Conversion index: -	Data type: u_int8	Change during operation: True

Different parameters can be assigned to PCD 3–10 of the PPOs (the number of PCDs depends on the PPO type). The values in PCD 3–10 are written to the selected parameters as data values.

Table 194: Option:

[0]	None
[1]	[302] Minimum reference
[2]	[303] Maximum reference
[3]	[341] Ramp 1 ramp up time
[4]	[342] Ramp 1 ramp down time
[5]	[351] Ramp 2 ramp up time
[6]	[352] Ramp 2 ramp down time
[7]	[380] Jog ramp time
[8]	[381] Quick stop time
[9]	[412] Motor speed low limit [Hz]
[10]	[414] Motor speed high limit [Hz]
[11]	[590] Digital & relay bus control
[12]	[676] Terminal 45 output bus control
[13]	[696] Terminal 42 output bus control
[14]	[894] Bus feedback 1
[15]	FC port CTW
[16]	FC port REF
[17]	[2021] Setpoint1
[18]	[311] Jog speed [Hz]
[21]	[553] Term. 29 high ref./feedb. value
[22]	[615] Terminal 53 high ref./feedb. value
[23]	[625] Terminal 54 high ref./feedb. value
[24]	[895] Bus feedback 2
[81]	User define 1
[82]	User define 2
[83]	User define 3
[84]	User define 4
[85]	User define 5

[86]	User define 6
[87]	User define 7
[88]	User define 8

8-43 PCD Read Configuration

Default value: [0] None	Parameter type: Option	2-setup: All setups
Conversion index: -	Data type: u_int8	Change during operation: True

Different parameters can be assigned to PCD 3–10 of the PPOs (the number of PCDs depends on the PPO type). PCD 3–10 hold the actual data value of the selected parameters.

Table 195: Option:

[0]	None
[1]	[1500] Operation hours
[2]	[1501] Running hours
[3]	[1502] kWh counter
[4]	[1600] Control word
[5]	[1601] Reference [Unit]
[6]	[1602] Reference %
[7]	[1603] Status word
[8]	[1605] Main actual value [%]
[9]	[1609] Custom readout
[10]	[1610] Power [kW]
[11]	[1611] Power [hp]
[12]	[1612] Motor voltage
[13]	[1613] Frequency
[14]	[1614] Motor current
[15]	[1615] Frequency [%]
[16]	[1618] Motor thermal
[17]	[1630] DC link voltage
[18]	[1634] Heatsink temp.
[19]	[1635] Inverter thermal
[20]	[1638] SL controller state
[21]	[1650] External teference
[22]	[1652] Feedback [Unit]
[23]	[1660] Digital input 18, 19, 27, 33
[24]	[1661] Terminal 53 switch setting

[25]	[1662] Analog input 53
[26]	[1663] Terminal 54 switch setting
[27]	[1664] Analog input 54
[28]	[1665] Analog output 42 [mA]
[29]	[1671] Relay output
[30]	[1672] Counter A
[31]	[1673] Counter B
[32]	[1690] Alarm word
[33]	[1692] Warning word
[34]	[1694] Ext. status word
[36]	[1850] Sensorless readout [unit]
[38]	[1622] Torque [%]
[39]	[1691] Alarm word 2
[40]	[1693] Warning word 2
[42]	[1679] Analog output 45 [mA]
[43]	[1617] Speed [RPM]
[44]	[1666] Digital output
[45]	[894] Bus feedback 1
[46]	[1616] Torque [Nm]
[47]	[1626] Power filtered [kW]
[48]	[1627] Power filtered [hp]
[49]	[1652] Feedback[Unit]
[50]	[1654] Feedback 1 [Unit]
[51]	[1655] Feedback 2 [Unit]
[52]	[1667] Pulse input 29 [Hz]
[54]	[1695] Ext. status word 2
[55]	[1888] Motor current
[81]	User define 1
[82]	User define 2
[83]	User define 3
[84]	User define 4
[85]	User define 5
[86]	User define 6

[87]	User define 7
[88]	User define 8
[100]	[1605] Main actual value [N2]

4.9.4 8-5* Digital/Bus

Parameters for configuring the control word digital/bus merging.

8-50 Coasting Select

Default value: [3] Logic OR	Parameter type: Option	2-setup: All setups
Conversion index: -	Data type: u_int8	Change during operation: True

N O T I C E

This parameter is active only when *parameter 8-01 Control Site* is set to [0] Digital and control word.

Select control of the coasting function via the terminals (digital input) and/or via the bus.

Table 196: Option:

[0]	Digital input	Activate coast via a digital input.
[1]	Bus	Activate coast via the serial communication port.
[2]	Logic AND	Activate coast via the fieldbus/serial communication port, and via 1 of the digital inputs.
[3]	Logic OR	Activate coast via the serial communication port or via 1 of the digital inputs.

8-51 Quick Stop Select

Default value: [3] Logic OR	Parameter type: Option	2-setup: All setups
Conversion index: -	Data type: u_int8	Change during operation: True

N O T I C E

This parameter is active only when *parameter 8-01 Control Site* is set to [0] Digital and control word.

Select control of the quick stop function via the terminals (digital input) and/or via the bus.

Table 197: Option:

[0]	Digital input	Activate quick stop via a digital input.
[1]	Bus	Activate quick stop via the serial communication port.
[2]	Logic AND	Activate quick stop via the fieldbus/serial communication port, and via 1 of the digital inputs.
[3]	Logic OR	Activate quick stop via the serial communication port or via 1 of the digital inputs.

8-52 DC Brake Select

Default value: -	Parameter type: Option	2-setup: All setups
Conversion index: -	Data type: u_int8	Change during operation: True

N O T I C E

This parameter is active only when *parameter 8-01 Control Site* is set to [0] Digital and control word.

Select control of the DC brake function via the terminals (digital input) and/or via the bus.

Table 198: Option:

[0]	Digital input	Activate DC brake via a digital input.
[1]	Bus	Activate DC brake via the serial communication port.
[2]	Logic AND	Activate DC brake via the fieldbus/serial communication port, and via 1 of the digital inputs.
[3]	Logic OR	Activate DC brake via the serial communication port or via 1 of the digital inputs.

8-53 Start Select

Default value: [3] Logic OR	Parameter type: Option	2-setup: All setups
Conversion index: -	Data type: u_int8	Change during operation: True

NOTICE

This parameter is active only when *parameter 8-01 Control Site* is set to [0] Digital and control word.

Select control of the drive start function via the terminals (digital input) and/or via the bus.

Table 199: Option:

[0]	Digital input	Activate a start command via a digital input.
[1]	Bus	Activate a start command via the serial communication port.
[2]	Logic AND	Activate a start command via the fieldbus/serial communication port, and via 1 of the digital inputs.
[3]	Logic OR	Activate a start command via the serial communication port or via 1 of the digital inputs.

8-54 Reversing Select

Default value: [0] Digital input	Parameter type: Option	2-setup: All setups
Conversion index: -	Data type: u_int8	Change during operation: True

NOTICE

This parameter is active only when *parameter 8-01 Control Site* is set to [0] Digital and control word.

Select control of the drive reverse function via the terminals (digital input) and/or via the bus.

Table 200: Option:

[0]	Digital input	Activate a reverse command via a digital input.
[1]	Bus	Activate a reverse command via the serial communication port.
[2]	Logic AND	Activate a reverse command via the fieldbus/serial communication port, and via 1 of the digital inputs.
[3]	Logic OR	Activate a reverse command via the serial communication port or via 1 of the digital inputs.

8-55 Set-up Select

Default value: [3] Logic OR	Parameter type: Option	2-setup: All setups
Conversion index: -	Data type: u_int8	Change during operation: True

NOTICE

This parameter is active only when *parameter 8-01 Control Site* is set to [0] Digital and control word.

Select control of the drive setup selection via the terminals (digital input) and/or via the bus.

Table 201: Option:

[0]	Digital input	Activate the setup selection via a digital input.
[1]	Bus	Activate the setup selection via the serial communication port.
[2]	Logic AND	Activate the setup selection via the fieldbus/serial communication port, and via 1 of the digital inputs.
[3]	Logic OR	Activate the setup selection via the serial communication port or via 1 of the digital inputs.

8-56 Preset Reference Select

Default value: [3] Logic OR	Parameter type: Option	2-setup: All setups
Conversion index: -	Data type: u_int8	Change during operation: True

N O T I C E

This parameter is active only when *parameter 8-01 Control Site* is set to [0] Digital and control word.

Select control of the drive preset reference selection via the terminals (digital input) and/or via the bus.

Table 202: Option:

[0]	Digital input	Activate the preset reference selection via a digital input.
[1]	Bus	Activate the preset reference selection via the serial communication port.
[2]	Logic AND	Activate the preset reference selection via the fieldbus/serial communication port, and via 1 of the digital inputs.
[3]	Logic OR	Activate the preset reference selection via the serial communication port or via 1 of the digital inputs.

4.9.5 8-7* BACnet

8-70 BACnet Device Instance

Default value: 1	Parameter type: Range	2-setup: 1 setup
Conversion index: 0	Data type: u_int32	Change during operation: True

Enter a unique ID number for the BACnet device.

Table 203: Range:

Min: 0	Max: 4194303	Default value: 1
--------	--------------	------------------

8-72 MS/TP Max Masters

Default value: 127	Parameter type: Range	2-setup: 1 setup
Conversion index: 0	Data type: u_int8	Change during operation: True

Define the address of the master, which holds the highest address in this network. Decreasing this value optimizes polling for the token.

Table 204: Range:

Min: 0	Max: 127	Default value: 127
--------	----------	--------------------

8-73 MS/TP Max Info Frames

Default value: 1	Parameter type: Range	2-setup: 1 setup
Conversion index: 0	Data type: u_int16	Change during operation: True

Define how many info/data frames the device is allowed to send while holding the token.

Table 205: Range:

Min: 1	Max: 65534	Default value: 1
--------	------------	------------------

8-74 "I am" Service

Default value: [0] Send at power-up	Parameter type: Option	2-setup: 1 setup
Conversion index: -	Data type: u_int8	Change during operation: True

Table 206: Option:

[0]	Send at power-up	Select when the device should send the <i>I am service</i> message only at power-up.
[1]	Continuously	Select when the device should send the <i>I am service</i> message continuously with an interval of approximately 1 minute.

8-75 Intialisation Password

Default value: admin	Parameter type: Range	2-setup: 1 setup
Conversion index: 0	Data type: VisibleString	Change during operation: True

Enter the password needed for execution of Drive Re-initialization from BACnet.

Table 207: Range:

Min: 1	Max: 1	Default value: admin
--------	--------	----------------------

8-79 Protocol Firmware version

Default value: 0	Parameter type: Range	2-setup: 1 setup
Conversion index: -2	Data type: u_int16	Change during operation: False

Firmware revision of the drive is in index 0, Modbus is in index 1, Metasys N2 is in index 2, FLN is in index 3, BACnet is in index 4.

Table 208: Range:

Min: 0	Max: 655	Default value: 0
--------	----------	------------------

4.9.6 8-8* FC Port Diagnostics

These parameters are used for monitoring the bus communication via the FC port.

8-80 Bus Message Count

Default value: 0	Parameter type: Range	2-setup: 1 setup
Conversion index: 0	Data type: u_int32	Change during operation: True

This parameter shows the number of valid telegrams detected on the bus.

Table 209: Range:

Min: 0	Max: 4294967295	Default value: 0
--------	-----------------	------------------

8-81 Bus Error Count

Default value: 0	Parameter type: Range	2-setup: 1 setup
Conversion index: 0	Data type: u_int32	Change during operation: True

This parameter shows the number of telegrams with faults (for example, CRC fault), detected on the bus.

Table 210: Range:

Min: 0	Max: 4294967295	Default value: 0
--------	-----------------	------------------

8-82 Slave Messages Rcvd

Default value: 0	Parameter type: Range	2-setup: 1 setup
Conversion index: 0	Data type: u_int32	Change during operation: True

This parameter shows the number of valid telegrams addressed to the slave, sent by the drive.

Table 211: Range:

Min: 0	Max: 4294967295	Default value: 0
--------	-----------------	------------------

8-83 Slave Error Count

Default value: 0	Parameter type: Range	2-setup: 1 setup
Conversion index: 0	Data type: u_int32	Change during operation: True

This parameter shows the number of error telegrams, which the drive could not execute.

Table 212: Range:

Min: 0	Max: 4294967295	Default value: 0
--------	-----------------	------------------

8-84 Slave Messages Sent

Default value: 0	Parameter type: Range	2-setup: 1 setup
Conversion index: 0	Data type: u_int32	Change during operation: True

This parameter shows the number of messages sent from the slave.

Table 213: Range:

Min: 0	Max: 4294967295	Default value: 0
--------	-----------------	------------------

8-85 Slave Timeout Errors

Default value: 0	Parameter type: Range	2-setup: 1 setup
Conversion index: 0	Data type: u_int32	Change during operation: True

This parameter shows the number of slave timeout errors.

Table 214: Range:

Min: 0	Max: 4294967295	Default value: 0
--------	-----------------	------------------

8-88 Reset FC port Diagnostics

Default value: [0] Do not reset	Parameter type: Option	2-setup: 1 setup
Conversion index: -	Data type: u_int8	Change during operation: True

Table 215: Option:

[0]	Do not reset
[1]	Reset counter

4.9.7 8-9* Bus Feedback

8-94 Bus Feedback 1

Default value: 0	Parameter type: Range	2-setup: All setups
Conversion index: 0	Data type: int16	Change during operation: True

Write feedback to this parameter via the serial communication port. Select this parameter in *parameter 20-00 Feedback 1 Source* as a feedback source. Hex value 4000 h corresponds to 100% feedback/range is ±200%.

Table 216: Range:

Min: -32768	Max: 32767	Default value: 0
-------------	------------	------------------

8-95 Bus Feedback 2

Default value: 0	Parameter type: Range	2-setup: 1 setup
Conversion index: 0	Data type: int16	Change during operation: True

This parameter allows setting of a bus feedback value via the serial communication port or options which forms part of the feedback handling. Bus Feedback may be chosen as feedback source.

Table 217: Range:

Min: -32768	Max: 32767	Default value: 0
-------------	------------	------------------

4.10 Parameter Group 13-*** Smart Logic

Smart logic control (SLC) is a sequence of user-defined actions (see *parameter 13-52 SL Controller Action [x]*) executed by the SLC when the SLC evaluates the associated user-defined event (see *parameter 13-51 SL Controller Event [x]*) as true. Events and actions are each numbered and linked in pairs. This means that when [0] event is fulfilled (attains the value true), [0] action is executed. After executing this action, the conditions of [1] event is evaluated. If it is evaluated as true, [1] action is executed, and so on. Only 1 event is evaluated at any time. If an event is evaluated as false, nothing happens (in the SLC) during the current scan interval and no other events are evaluated. This means that when the SLC starts, it evaluates [0] event (and only [0] event) each scan interval. Only when [0] event is evaluated as true, the SLC executes [0] action and starts evaluating [1] event. It is possible to program from 1–20 events and actions. When the last event/action has been executed, the sequence starts over again from [0] event/[0] action.

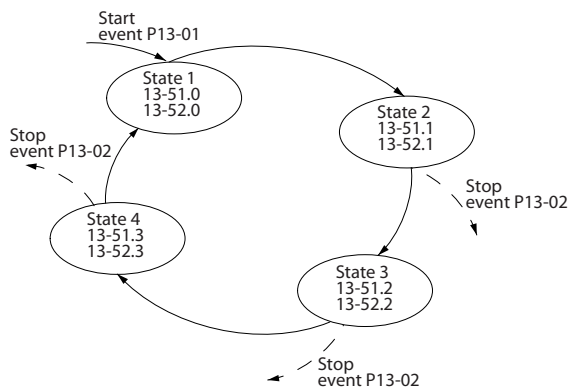

Illustration 15: Example with 3 Event/Actions

Starting and stopping the SLC

To start or stop the SLC, select [1] On or [2] Off in *parameter 13-00 SL Controller Mode*. The SLC always starts in state 0 (where it evaluates [0] event). The SLC starts when the start event (defined in *parameter 13-01 Start Event*) is evaluated as true (if [1] On is selected in *parameter 13-00 SL Controller Mode*). The SLC stops when the stop event (*parameter 13-02 Stop Event*) is true. *Parameter 13-03 Reset SLC* resets all SLC parameters and starts programming from the beginning.

4.10.1 13-0* SLC Settings

To activate, deactivate, and reset the smart logic control sequence, use the SLC settings. The logic functions and comparators are always running in the background, which opens for separate control of digital inputs and outputs.

13-00 SL Controller Mode

Default value: [0] Off	Parameter type: Option	2-setup: 1 setup
Conversion index: -	Data type: u_int8	Change during operation: True

To enable the smart logic control to start when a start command is present, for example, via a digital input, Select [1] On. To disable the smart logic control, select [0] Off.

Table 218: Option:

[0]	Off	Disable the smart logic controller.
[1]	On	Enable the smart logic controller.

13-01 Start Event

Default value: [39] Start command	Parameter type: Option	2-setup: 1 setup
Conversion index: -	Data type: u_int8	Change during operation: True

To activate smart logic control, select the boolean (True or False) input.

Table 219: Option:

[0]	False	Enter the fixed value False in the logic rule.
[1]	True	Enter the fixed value True in the logic rule.
[2]	Running	The motor runs.
[3]	In range	The motor runs within programmed current ranges (<i>parameter 4-50 Warning Current Low and parameter 4-51 Warning Current High</i>).
[4]	On reference	The motor runs at reference speed.
[7]	Out of current range	The motor current is outside the range set in <i>parameter 4-18 Current Limit</i> .
[8]	Below I low	The motor current is lower than set in <i>parameter 4-50 Warning Current Low</i> .
[9]	Above I high	The motor current is higher than set in <i>parameter 4-51 Warning Current High</i> .
[16]	Thermal warning	The thermal warning turns on when the temperature exceeds the limit in the motor, the drive, or the thermistor.
[17]	Mains out of range	Mains phase loss warning or alarm, if <i>parameter 14-12 Function at Mains Imbalance</i> is not set at [2] Disabled.
[18]	Reversing	The drive reverses.
[19]	Warning	A warning is present.
[20]	Alarm (trip)	An alarm is present.
[21]	Alarm (trip lock)	A trip lock alarm is present.
[22]	Comparator 0	Use the result of comparator 0 in the logic rule.
[23]	Comparator 1	Use the result of comparator 1 in the logic rule.
[24]	Comparator 2	Use the result of comparator 2 in the logic rule.
[25]	Comparator 3	Use the result of comparator 3 in the logic rule.
[26]	Logic rule 0	Use the result of logic rule 0 in the logic rule.

[27]	Logic rule 1	Use the result of logic rule 1 in the logic rule.
[28]	Logic rule 2	Use the result of logic rule 2 in the logic rule.
[29]	Logic rule 3	Use the result of logic rule 3 in the logic rule.
[33]	Digital input DI18	Use the value of DI18 in the logic rule (High = True).
[34]	Digital input DI19	Use the value of DI19 in the logic rule (High = True).
[35]	Digital input DI27	Use the value of DI27 in the logic rule (High = True).
[36]	Digital input DI29	Use the value of DI29 in the logic rule (High = True).
[39]	Start command	This event is True if the drive is started by any means (either via digital input, or other).
[40]	Drive stopped	This event is True if the drive is stopped or coasted by any means (either via digital input, or other).
[42]	Auto Reset Trip	This event is True if the drive is tripped (but not trip-locked) and an automatic reset is issued.
[50]	Comparator 4	Use the result of comparator 4 in the logic rule.
[51]	Comparator 5	Use the result of comparator 5 in the logic rule.
[60]	Logic rule 4	Use the result of logic rule 4 in the logic rule.
[61]	Logic rule 5	Use the result of logic rule 5 in the logic rule.
[83]	Broken Belt	A broken-belt condition has been detected. Enable this function in <i>parameter 22-60 Broken Belt Function</i> .

13-02 Stop Event

Default value: [40] Drive stopped	Parameter type: Option	2-setup: 1 setup
Conversion index: -	Data type: u_int8	Change during operation: True

Select the condition (True or False) which deactivates the smart logic controller.

Table 220: Option:

[0]	False	Enter the fixed value False in the logic rule.
[1]	True	Enter the fixed value True in the logic rule.
[2]	Running	See <i>parameter 13-01 Start Event</i> for further description.
[3]	In range	See <i>parameter 13-01 Start Event</i> for further description.
[4]	On reference	See <i>parameter 13-01 Start Event</i> for further description.
[7]	Out of current range	See <i>parameter 13-01 Start Event</i> for further description.
[8]	Below I low	See <i>parameter 13-01 Start Event</i> for further description.
[9]	Above I high	See <i>parameter 13-01 Start Event</i> for further description.
[16]	Thermal warning	See <i>parameter 13-01 Start Event</i> for further description.
[17]	Mains out of range	See <i>parameter 13-01 Start Event</i> for further description.
[18]	Reversing	See <i>parameter 13-01 Start Event</i> for further description.
[19]	Warning	See <i>parameter 13-01 Start Event</i> for further description.
[20]	Alarm (trip)	See <i>parameter 13-01 Start Event</i> for further description.

[21]	Alarm (trip lock)	See <i>parameter 13-01 Start Event</i> for further description.
[22]	Comparator 0	Use the result of comparator 0 in the logic rule.
[23]	Comparator 1	Use the result of comparator 1 in the logic rule.
[24]	Comparator 2	Use the result of comparator 2 in the logic rule.
[25]	Comparator 3	Use the result of comparator 3 in the logic rule.
[26]	Logic rule 0	Use the result of logic rule 0 in the logic rule.
[27]	Logic rule 1	Use the result of logic rule 1 in the logic rule.
[28]	Logic rule 2	Use the result of logic rule 2 in the logic rule.
[29]	Logic rule 3	Use the result of logic rule 3 in the logic rule.
[30]	SL Time-out 0	Use the result of timer 0 in the logic rule.
[31]	SL Time-out 1	Use the result of timer 1 in the logic rule.
[32]	SL Time-out 2	Use the result of timer 2 in the logic rule.
[33]	Digital input DI18	Use the value of DI18 in the logic rule (High = True).
[34]	Digital input DI19	Use the value of DI19 in the logic rule (High = True).
[35]	Digital input DI27	Use the value of DI27 in the logic rule (High = True).
[36]	Digital input DI29	Use the value of DI29 in the logic rule (High = True).
[39]	Start command	This event is True if the drive is started by any means (either via digital input, or other).
[40]	Drive stopped	This event is True if the drive is stopped or coasted by any means (either via digital input, or other).
[42]	Auto Reset Trip	This event is True if the drive is tripped (but not trip-locked) and an automatic reset is issued.
[50]	Comparator 4	Use the result of comparator 4 in the logic rule.
[51]	Comparator 5	Use the result of comparator 5 in the logic rule.
[60]	Logic rule 4	Use the result of logic rule 4 in the logic rule.
[61]	Logic rule 5	Use the result of logic rule 5 in the logic rule.
[70]	SL Time-out 3	Use the result of timer 3 in the logic rule.
[71]	SL Time-out 4	Use the result of timer 4 in the logic rule.
[72]	SL Time-out 5	Use the result of timer 5 in the logic rule.
[73]	SL Time-out 6	Use the result of timer 6 in the logic rule.
[74]	SL Time-out 7	Use the result of timer 7 in the logic rule.
[81]	Dry Pump	A dry-pump condition has been detected. Enable this function in <i>parameter 22-26 Dry Pump Function</i> .
[82]	End of Curve	An end-of-curve condition has been detected. Enable this function in <i>parameter 22-50 End of Curve Function</i> .
[83]	Broken Belt	A broken-belt condition has been detected. Enable this function in <i>parameter 22-60 Broken Belt Function</i> .

13-03 Reset SLC

Default value: [0] Do not reset SLC	Parameter type: Option	2-setup: 1 setup
Conversion index: -	Data type: u_int8	Change during operation: True

Table 221: Option:

[0]	Do not reset SLC	Retain programmed settings in <i>parameter group 13-** Smart Logic</i> .
[1]	Reset SLC	Reset all parameters in <i>parameter group 13-** Smart Logic</i> to default settings.

4.10.2 13-1* Comparators

Comparators are used for comparing continuous variables (such as output frequency, output current, and analog input) to fixed preset values.

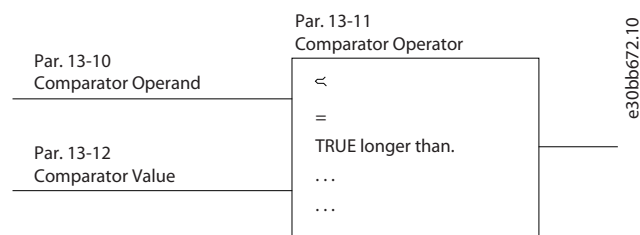

Illustration 16: Comparators

In addition, there are digital values that are compared to fixed time values. See the explanation in *parameter 13-10 Comparator Operand*. Comparators are evaluated once in each scan interval. Use the result (True or False) directly. All parameters in this parameter group are array parameters with index 0–5. Select index 0 to program comparator 0, select index 1 to program comparator 1, and so on.

13-10 Comparator Operand

Default value: [0] Disabled	Parameter type: Option	2-setup: 1 setup
Conversion index: -	Data type: u_int8	Change during operation: True

Select the variable to be monitored by the comparator.

Table 222: Option:

[0]	Disabled
[1]	Reference
[2]	Feedback
[3]	Motor speed
[4]	Motor current
[6]	Motor power
[7]	Motor voltage
[12]	Analog input AI53
[13]	Analog input AI54
[20]	Alarm number
[30]	Counter A
[31]	Counter B

13-11 Comparator Operator

Default value: [1] Approx.Equal (~)	Parameter type: Option	2-setup: 1 setup
Conversion index: -	Data type: u_int8	Change during operation: True

Table 223: Option:

[0]	Less Than (<)	Select [0]< for the result of the evaluation to be True, when the variable selected in <i>parameter 13-10 Comparator Operand</i> is smaller than the fixed value in <i>parameter 13-12 Comparator Value</i> . The result is False, if the variable selected in <i>parameter 13-10 Comparator Operand</i> is greater than the fixed value in <i>parameter 13-12 Comparator Value</i> .
[1]	Approx.Equal (~)	Select [1]≈ for the result of the evaluation to be True, when the variable selected in <i>parameter 13-10 Comparator Operand</i> is approximately equal to the fixed value in <i>parameter 13-12 Comparator Value</i> .
[2]	Greater Than (>)	Select [2]> for the inverse logic of option [0]<.

13-12 Comparator Value

Default value: 0	Parameter type: Range	2-setup: 1 setup
Conversion index: -3	Data type: int32	Change during operation: True

Enter the trigger level for the variable that is monitored by this comparator. This parameter is an array parameter containing comparator values 0–9.

Table 224: Range:

Min: -9999	Max: 9999	Default value: 0
------------	-----------	------------------

4.10.3 13-2* Timers

Use the result (True or False) from timers directly to define an event (see *parameter 13-51 SL Controller Event*), or as boolean input in a logic rule (see *parameter 13-40 Logic Rule Boolean 1*, *parameter 13-42 Logic Rule Boolean 2*, or *parameter 13-44 Logic Rule Boolean 3*). A timer is only False when started by an action (for example [29] *Start timer 1*) until the timer value entered in this parameter has elapsed. Then it becomes True again.

All parameters in this parameter group are array parameters with index 0–2. Select index 0 to program timer 0, select index 1 to program timer 1, and so on.

13-20 SL Controller Timer

Default value: 0 s	Parameter type: Range	2-setup: 1 setup
Conversion index: -2	Data type: u_int32	Change during operation: True

Enter the value to define the duration of the False output from the programmed timer. A timer is only False if it is started by an action (see *parameter 13-52 SL Controller Action [29–31]* and *parameter 13-52 SL Controller Action [70–74] Start timer X*) and until the timer value has elapsed. Array parameters contain timers 0–7.

Table 225: Range:

Min: 0 s	Max: 3600 s	Default value: 0 s
----------	-------------	--------------------

4.10.4 13-4* Logic Rules

Combine up to 3 boolean inputs (True/False inputs) from timers, comparators, digital inputs, status bits, and events using the logical operators AND, OR, and NOT. Select boolean inputs for the calculation in *parameter 13-40 Logic Rule Boolean 1*, *parameter 13-42 Logic Rule Boolean 2*, and *parameter 13-44 Logic Rule Boolean 3*. Define the operators used to combine the selected inputs logically in *parameter 13-41 Logic Rule Operator 1* and *parameter 13-43 Logic Rule Operator 2*.

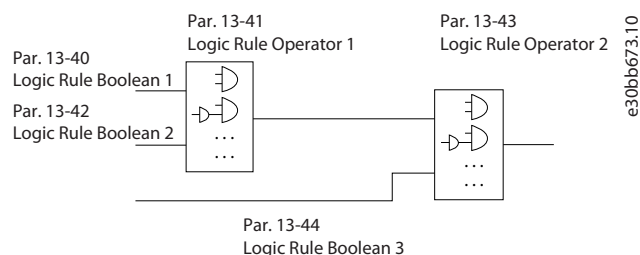

Illustration 17: Logic Rules

Priority of calculation

The results of *parameter 13-40 Logic Rule Boolean 1*, *parameter 13-41 Logic Rule Operator 1*, and *parameter 13-42 Logic Rule Boolean 2* are calculated first. The outcome (True/False) of this calculation is combined with the settings of *parameter 13-43 Logic Rule Operator 2* and *parameter 13-44 Logic Rule Boolean 3*, yielding the final result (True/False) of the logic rule.

13-40 Logic Rule Boolean 1

Default value: [0] False	Parameter type: Option	2-setup: 1 setup
Conversion index: -	Data type: u_int8	Change during operation: True

Select the 1st boolean (True or False) input for the selected logic rule.

Table 226: Option:

[0]	False	Enter the fixed value of False in the logic rule.
[1]	True	Enter the fixed value True in the logic rule.
[2]	Running	See <i>parameter 13-01 Start Event</i> for further description.
[3]	In range	See <i>parameter 13-01 Start Event</i> for further description.
[4]	On reference	See <i>parameter 13-01 Start Event</i> for further description.
[7]	Out of current range	See <i>parameter 13-01 Start Event</i> for further description.
[8]	Below I low	See <i>parameter 13-01 Start Event</i> for further description.
[9]	Above I high	See <i>parameter 13-01 Start Event</i> for further description.
[16]	Thermal warning	See <i>parameter 13-01 Start Event</i> for further description.
[17]	Mains out of range	See <i>parameter 13-01 Start Event</i> for further description.
[18]	Reversing	See <i>parameter 13-01 Start Event</i> for further description.
[19]	Warning	See <i>parameter 13-01 Start Event</i> for further description.
[20]	Alarm (trip)	See <i>parameter 13-01 Start Event</i> for further description.
[21]	Alarm (trip lock)	See <i>parameter 13-01 Start Event</i> for further description.
[22]	Comparator 0	Use the result of comparator 0 in the logic rule.
[23]	Comparator 1	Use the result of comparator 1 in the logic rule.
[24]	Comparator 2	Use the result of comparator 2 in the logic rule.
[25]	Comparator 3	Use the result of comparator 3 in the logic rule.
[26]	Logic rule 0	Use the result of logic rule 0 in the logic rule.
[27]	Logic rule 1	Use the result of logic rule 1 in the logic rule.

[28]	Logic rule 2	Use the result of logic rule 2 in the logic rule.
[29]	Logic rule 3	Use the result of logic rule 3 in the logic rule.
[30]	SL Time-out 0	Use the result of timer 0 in the logic rule.
[31]	SL Time-out 1	Use the result of timer 1 in the logic rule.
[32]	SL Time-out 2	Use the result of timer 2 in the logic rule.
[33]	Digital input DI18	Use the value of DI18 in the logic rule (High = True).
[34]	Digital input DI19	Use the value of DI19 in the logic rule (High = True).
[35]	Digital input DI27	Use the value of DI27 in the logic rule (High = True).
[36]	Digital input DI29	Use the value of DI29 in the logic rule (High = True).
[39]	Start command	This logic rule is True if the drive is started by any means (either via digital input, or other).
[40]	Drive stopped	This logic rule is True if the drive is stopped or coasted by any means (either via digital input, or other).
[42]	Auto Reset Trip	This logic rule is True if the drive is tripped (but not trip-locked) and an automatic reset is issued.
[50]	Comparator 4	Use the result of comparator 4 in the logic rule.
[51]	Comparator 5	Use the result of comparator 5 in the logic rule.
[60]	Logic rule 4	Use the result of logic rule 4 in the logic rule.
[61]	Logic rule 5	Use the result of logic rule 5 in the logic rule.
[70]	SL Time-out 3	Use the result of timer 3 in the logic rule.
[71]	SL Time-out 4	Use the result of timer 4 in the logic rule.
[72]	SL Time-out 5	Use the result of timer 5 in the logic rule.
[73]	SL Time-out 6	Use the result of timer 6 in the logic rule.
[74]	SL Time-out 7	Use the result of timer 7 in the logic rule.
[81]	Dry Pump	A dry-pump condition has been detected. Enable this function in <i>parameter 22-26 Dry Pump Function</i> .
[82]	End of Curve	An end-of-curve condition has been detected. Enable this function in <i>parameter 22-50 End of Curve Function</i> .
[83]	Broken Belt	A broken-belt condition has been detected. Enable this function in <i>parameter 22-60 Broken Belt Function</i> .

13-41 Logic Rule Operator 1

Default value: [0] Disabled	Parameter type: Option	2-setup: 1 setup
Conversion index: -	Data type: u_int8	Change during operation: True

Table 227: Option:

[0]	Disabled
[1]	AND
[2]	OR

[3]	AND NOT
[4]	OR NOT
[5]	NOT AND
[6]	NOT OR
[7]	NOT AND NOT
[8]	NOT OR NOT

13-42 Logic Rule Boolean 2

Default value: [0] False	Parameter type: Option	2-setup: 1 setup
Conversion index: -	Data type: u_int8	Change during operation: True

Select the 2nd boolean (True or False) input for the selected logic rule.

Table 228: Option:

[0]	False	Enter the fixed value of False in the logic rule.
[1]	True	Enter the fixed value True in the logic rule.
[2]	Running	See <i>parameter 13-01 Start Event</i> for further description.
[3]	In range	See <i>parameter 13-01 Start Event</i> for further description.
[4]	On reference	See <i>parameter 13-01 Start Event</i> for further description.
[7]	Out of current range	See <i>parameter 13-01 Start Event</i> for further description.
[8]	Below I low	See <i>parameter 13-01 Start Event</i> for further description.
[9]	Above I high	See <i>parameter 13-01 Start Event</i> for further description.
[16]	Thermal warning	See <i>parameter 13-01 Start Event</i> for further description.
[17]	Mains out of range	See <i>parameter 13-01 Start Event</i> for further description.
[18]	Reversing	See <i>parameter 13-01 Start Event</i> for further description.
[19]	Warning	See <i>parameter 13-01 Start Event</i> for further description.
[20]	Alarm (trip)	See <i>parameter 13-01 Start Event</i> for further description.
[21]	Alarm (trip lock)	See <i>parameter 13-01 Start Event</i> for further description.
[22]	Comparator 0	Use the result of comparator 0 in the logic rule.
[23]	Comparator 1	Use the result of comparator 1 in the logic rule.
[24]	Comparator 2	Use the result of comparator 2 in the logic rule.
[25]	Comparator 3	Use the result of comparator 3 in the logic rule.
[26]	Logic rule 0	Use the result of logic rule 0 in the logic rule.
[27]	Logic rule 1	Use the result of logic rule 1 in the logic rule.
[28]	Logic rule 2	Use the result of logic rule 2 in the logic rule.
[29]	Logic rule 3	Use the result of logic rule 3 in the logic rule.

[30]	SL Time-out 0	Use the result of timer 0 in the logic rule.
[31]	SL Time-out 1	Use the result of timer 1 in the logic rule.
[32]	SL Time-out 2	Use the result of timer 2 in the logic rule.
[33]	Digital input DI18	Use the value of DI18 in the logic rule (High = True).
[34]	Digital input DI19	Use the value of DI19 in the logic rule (High = True).
[35]	Digital input DI27	Use the value of DI27 in the logic rule (High = True).
[36]	Digital input DI29	Use the value of DI29 in the logic rule (High = True).
[39]	Start command	This logic rule is True if the drive is started by any means (either via digital input, or other).
[40]	Drive stopped	This logic rule is True if the drive is stopped or coasted by any means (either via digital input, or other).
[42]	Auto Reset Trip	This logic rule is True if the drive is tripped (but not trip-locked) and an automatic reset is issued.
[50]	Comparator 4	Use the result of comparator 4 in the logic rule.
[51]	Comparator 5	Use the result of comparator 5 in the logic rule.
[60]	Logic rule 4	Use the result of logic rule 4 in the logic rule.
[61]	Logic rule 5	Use the result of logic rule 5 in the logic rule.
[70]	SL Time-out 3	Use the result of timer 3 in the logic rule.
[71]	SL Time-out 4	Use the result of timer 4 in the logic rule.
[72]	SL Time-out 5	Use the result of timer 5 in the logic rule.
[73]	SL Time-out 6	Use the result of timer 6 in the logic rule.
[74]	SL Time-out 7	Use the result of timer 7 in the logic rule.
[81]	Dry Pump	A dry-pump condition has been detected. Enable this function in <i>parameter 22-26 Dry Pump Function</i> .
[82]	End of Curve	An end-of-curve condition has been detected. Enable this function in <i>parameter 22-50 End of Curve Function</i> .
[83]	Broken Belt	A broken-belt condition has been detected. Enable this function in <i>parameter 22-60 Broken Belt Function</i> .

13-43 Logic Rule Operator 2

Default value: [0] Disabled	Parameter type: Option	2-setup: 1 setup
Conversion index: -	Data type: u_int8	Change during operation: True

Table 229: Option:

[0]	Disabled
[1]	AND
[2]	OR
[3]	AND NOT
[4]	OR NOT

[5]	NOT AND
[6]	NOT OR
[7]	NOT AND NOT
[8]	NOT OR NOT

13-44 Logic Rule Boolean 3

Default value: [0] False	Parameter type: Option	2-setup: 1 setup
Conversion index: -	Data type: u_int8	Change during operation: True

Select the 3rd boolean (True or False) input for the selected logic rule.

Table 230: Option:

[0]	False	Enter the fixed value of False in the logic rule.
[1]	True	Enter the fixed value True in the logic rule.
[2]	Running	See <i>parameter 13-01 Start Event</i> for further description.
[3]	In range	See <i>parameter 13-01 Start Event</i> for further description.
[4]	On reference	See <i>parameter 13-01 Start Event</i> for further description.
[7]	Out of current range	See <i>parameter 13-01 Start Event</i> for further description.
[8]	Below I low	See <i>parameter 13-01 Start Event</i> for further description.
[9]	Above I high	See <i>parameter 13-01 Start Event</i> for further description.
[16]	Thermal warning	See <i>parameter 13-01 Start Event</i> for further description.
[17]	Mains out of range	See <i>parameter 13-01 Start Event</i> for further description.
[18]	Reversing	See <i>parameter 13-01 Start Event</i> for further description.
[19]	Warning	See <i>parameter 13-01 Start Event</i> for further description.
[20]	Alarm (trip)	See <i>parameter 13-01 Start Event</i> for further description.
[21]	Alarm (trip lock)	See <i>parameter 13-01 Start Event</i> for further description.
[22]	Comparator 0	Use the result of comparator 0 in the logic rule.
[23]	Comparator 1	Use the result of comparator 1 in the logic rule.
[24]	Comparator 2	Use the result of comparator 2 in the logic rule.
[25]	Comparator 3	Use the result of comparator 3 in the logic rule.
[26]	Logic rule 0	Use the result of logic rule 0 in the logic rule.
[27]	Logic rule 1	Use the result of logic rule 1 in the logic rule.
[28]	Logic rule 2	Use the result of logic rule 2 in the logic rule.
[29]	Logic rule 3	Use the result of logic rule 3 in the logic rule.
[30]	SL Time-out 0	Use the result of timer 0 in the logic rule.
[31]	SL Time-out 1	Use the result of timer 1 in the logic rule.

[32]	SL Time-out 2	Use the result of timer 2 in the logic rule.
[33]	Digital input DI18	Use the value of DI18 in the logic rule (High = True).
[34]	Digital input DI19	Use the value of DI19 in the logic rule (High = True).
[35]	Digital input DI27	Use the value of DI27 in the logic rule (High = True).
[36]	Digital input DI29	Use the value of DI29 in the logic rule (High = True).
[39]	Start command	This logic rule is True if the drive is started by any means (either via digital input, or other).
[40]	Drive stopped	This logic rule is True if the drive is stopped or coasted by any means (either via digital input, or other).
[42]	Auto Reset Trip	This logic rule is True if the drive is tripped (but not trip-locked) and an automatic reset is issued.
[50]	Comparator 4	Use the result of comparator 4 in the logic rule.
[51]	Comparator 5	Use the result of comparator 5 in the logic rule.
[60]	Logic rule 4	Use the result of logic rule 4 in the logic rule.
[61]	Logic rule 5	Use the result of logic rule 5 in the logic rule.
[70]	SL Time-out 3	Use the result of timer 3 in the logic rule.
[71]	SL Time-out 4	Use the result of timer 4 in the logic rule.
[72]	SL Time-out 5	Use the result of timer 5 in the logic rule.
[73]	SL Time-out 6	Use the result of timer 6 in the logic rule.
[74]	SL Time-out 7	Use the result of timer 7 in the logic rule.
[81]	Dry Pump	A dry-pump condition has been detected. Enable this function in <i>parameter 22-26 Dry Pump Function</i> .
[82]	End of Curve	An end-of-curve condition has been detected. Enable this function in <i>parameter 22-50 End of Curve Function</i> .
[83]	Broken Belt	A broken-belt condition has been detected. Enable this function in <i>parameter 22-60 Broken Belt Function</i> .

4.10.5 13-5* States

Parameters for programming the smart logic controller.

13-51 SL Controller Event

Default value: [0] False	Parameter type: Option	2-setup: 1 setup
Conversion index: -	Data type: u_int8	Change during operation: True

Select the boolean input (True or False) to define the smart logic controller event. See *parameter 13-02 Stop Event* for further descriptions of options and their functions.

Table 231: Option:

[0]	False
[1]	True
[2]	Running
[3]	In range

[4]	On reference
[7]	Out of current range
[8]	Below I low
[9]	Above I high
[16]	Thermal warning
[17]	Mains out of range
[18]	Reversing
[19]	Warning
[20]	Alarm (trip)
[21]	Alarm (trip lock)
[22]	Comparator 0
[23]	Comparator 1
[24]	Comparator 2
[25]	Comparator 3
[26]	Logic rule 0
[27]	Logic rule 1
[28]	Logic rule 2
[29]	Logic rule 3
[30]	SL Time-out 0
[31]	SL Time-out 1
[32]	SL Time-out 2
[33]	Digital input DI18
[34]	Digital input DI19
[35]	Digital input DI27
[36]	Digital input DI29
[39]	Start command
[40]	Drive stopped
[42]	Auto Reset Trip
[50]	Comparator 4
[51]	Comparator 5
[60]	Logic rule 4
[61]	Logic rule 5
[70]	SL Time-out 3

[71]	SL Time-out 4
[72]	SL Time-out 5
[73]	SL Time-out 6
[74]	SL Time-out 7
[81]	Dry Pump
[82]	End of Curve
[83]	Broken Belt

13-52 SL Controller Action

Default value: [0] Disabled	Parameter type: Option	2-setup: 1 setup
Conversion index: -	Data type: u_int8	Change during operation: True

Select the action corresponding to the SLC event. Actions are executed when the corresponding event (defined in *parameter 13-51 SL Controller Event*) is evaluated as True.

Table 232: Option:

[0]	Disabled	This function is not activated.
[1]	No action	No action.
[2]	Select setup 1	Change the active setup (<i>parameter 0-10 Active Set-up</i>) to setup 1.
[3]	Select setup 2	Change the active setup (<i>parameter 0-10 Active Set-up</i>) to setup 2.
[10]	Select preset ref 0	Select preset reference 0.
[11]	Select preset ref 1	Select preset reference 1.
[12]	Select preset ref 2	Select preset reference 2.
[13]	Select preset ref 3	Select preset reference 3.
[14]	Select preset ref 4	Select preset reference 4.
[15]	Select preset ref 5	Select preset reference 5.
[16]	Select preset ref 6	Select preset reference 6.
[17]	Select preset ref 7	Select preset reference 7. If the active preset reference is changed, it merges with other preset reference commands coming from either the digital inputs or via a fieldbus.
[18]	Select ramp 1	Select ramp 1.
[19]	Select ramp 2	Select ramp 2.
[22]	Run	Issue a start command to the drive.
[23]	Run reverse	Issue a start reverse command to the drive.
[24]	Stop	Issue a stop command to the drive
[25]	Qstop	Issue a quick stop command to the drive.
[26]	DC Brake	Issue a DC stop command to the drive.
[27]	Coast	The drive coasts immediately. All stop commands including the coast command stop the SLC.

[28]	Freeze output	Freezes the output frequency of the drive.
[29]	Start timer 0	Start timer 0, see <i>parameter 13-20 SL Controller Timer</i> for further description.
[30]	Start timer 1	Start timer 1, see <i>parameter 13-20 SL Controller Timer</i> for further description.
[31]	Start timer 2	Start timer 2, see <i>parameter 13-20 SL Controller Timer</i> for further description.
[32]	Set digital out A low	Any output with digital output 1 selected is low (off).
[33]	Set digital out B low	Any output with digital output 2 selected is low (off).
[34]	Set digital out C low	Any output with digital output 3 selected is low (off).
[35]	Set digital out D low	Any output with digital output 4 selected is low (off).
[38]	Set digital out A high	Any output with digital output 1 selected is high (closed).
[39]	Set digital out B high	Any output with digital output 2 selected is high (closed).
[40]	Set digital out C high	Any output with digital output 3 selected is high (closed).
[41]	Set digital out D high	Any output with digital output 4 selected is high (closed).
[60]	Reset Counter A	Reset counter A to 0.
[61]	Reset Counter B	Reset counter B to 0.
[70]	Start Timer 3	Start timer 3, see <i>parameter 13-20 SL Controller Timer</i> for further description.
[71]	Start Timer 4	Start timer 4, see <i>parameter 13-20 SL Controller Timer</i> for further description.
[72]	Start Timer 5	Start timer 5, see <i>parameter 13-20 SL Controller Timer</i> for further description.
[73]	Start Timer 6	Start timer 6, see <i>parameter 13-20 SL Controller Timer</i> for further description.
[74]	Start Timer 7	Start timer 7, see <i>parameter 13-20 SL Controller Timer</i> for further description.
[100]	ResetAlarm	Reset the alarm.

4.11 Parameter Group 14-** Special Functions

4.11.1 14-0* Inverter Switching

14-01 Switching Frequency

Default value: [5] 5.0 kHz	Parameter type: Option	2-setup: All setups
Conversion index: -	Data type: u_int8	Change during operation: True

Select the inverter switching frequency. Changing the switching frequency can help to reduce acoustic noise from the motor.

N O T I C E

The output frequency value of the drive must never exceed 1/10 of the switching frequency. When the motor runs, adjust the switching frequency in *parameter 14-01 Switching Frequency* until the motor is as quiet as possible.

N O T I C E

High switching frequencies increase heat generation in the drive and may reduce its lifetime.

N O T I C E

Not all options are available in all power sizes.

Table 233: Option:

[0]	Ran3	3 kHz true random PWM (white noise modulation).
[1]	Ran5	5 kHz true random PWM (white noise modulation).
[2]	2.0 kHz	Select 2.0 kHz as the inverter switching frequency.
[3]	3.0 kHz	Select 3.0 kHz as the inverter switching frequency.
[4]	4.0 kHz	Select 4.0 kHz as the inverter switching frequency.
[5]	5.0 kHz	Select 5.0 kHz as the inverter switching frequency.
[6]	6.0 kHz	Select 6.0 kHz as the inverter switching frequency.
[7]	8.0 kHz	Select 8.0 kHz as the inverter switching frequency.
[8]	10.0 kHz	Select 10.0 kHz as the inverter switching frequency.
[9]	12.0 kHz	Select 12.0 kHz as the inverter switching frequency.
[10]	16.0 kHz	Select 16.0 kHz as the inverter switching frequency.

14-03 Overmodulation

Default value: [0] Off	Parameter type: Option	2-setup: All setups
Conversion index: -	Data type: u_int8	Change during operation: False

Table 234: Option:

[0]	Off	Select no overmodulation of the output voltage to avoid torque ripple on the motor shaft.
[1]	On	Select [1] On to obtain extra DC-link voltage and torque on the motor shaft.

14-07 Dead Time Compensation Level

Default value: Configuration dependent	Parameter type: Range	2-setup: All setups
Conversion index: 0	Data type: u_int8	Change during operation: False

Level of applied dead-time compensation in percentage. A high level (>90%) optimizes the dynamic motor response. A level 50–90% is suitable for both motortorque- ripple minimization and motor dynamics. A 0 level turns off the dead-time compensation.

Table 235: Range:

Min: 0	Max: 100	Default value: Configuration dependent
--------	----------	--

14-08 Damping Gain Factor

Default value: Configuration dependent	Parameter type: Range	2-setup: All setups
Conversion index: 0	Data type: u_int8	Change during operation: True

Set the damping factor for DC-link voltage compensation. See *parameter 14-51 DC-Link Voltage Compensation*.

Table 236: Range:

Min: 0%	Max: 100%	Default value: Configuration dependent
---------	-----------	--

14-09 Dead Time Bias Current Level

Default value: Configuration dependent	Parameter type: Range	2-setup: All setups
Conversion index: 0	Data type: u_int8	Change during operation: False

To add to the current-sense signal for dead time compensation for some motors, set a bias signal (in percentage).

Table 237: Range:

Min: 0%	Max: 100%	Default value: Configuration dependent
---------	-----------	--

4.11.2 14-1* Mains Failure

Parameters for configuring mains failure monitoring and handling.

14-10 Mains Failure

Default value: [0] No function	Parameter type: Option	2-setup: All setups
Conversion index: -	Data type: u_int8	Change during operation: False

Configure the action of the drive when the mains voltage is below the mains voltage limit configured in *parameter 14-11 Mains Fault Voltage Level*.

Table 238: Option:

[0]	No function
[3]	Coasting
[4]	Kinetic back-up
[5]	Kinetic back-up, trip
[6]	Alarm
[7]	Kin. back-up, trip w recovery

14-11 Mains Fault Voltage Level

Default value: 198 V	Parameter type: Range	2-setup: All setups
Conversion index: 0	Data type: u_int16	Change during operation: True

Use this parameter to define at which AC voltage the function selected in *parameter 14-10 Mains Failure* should be activated.

Table 239: Range:

Min: 100 V	Max: 800 V	Default value: 198 V
------------	------------	----------------------

14-12 Response to Mains Imbalance

Default value: [0] Trip	Parameter type: Option	2-setup: 1 setup
Conversion index: -	Data type: u_int8	Change during operation: True

Operation under severe mains imbalance conditions reduces the lifetime of the motor. If the motor is operated continuously near nominal load, conditions are considered severe. When a severe mains imbalance is detected, select 1 of the available functions.

N O T I C E

Selecting this option may reduce the lifetime of the drive.

Table 240: Option:

[0]	Trip	Trip the drive.
[1]	Warning	Issues a warning.
[2]	Disabled	No action.
[3]	Derate	The drive would derate.

14-15 Kin. Back-up Trip Recovery Level

Default value: 200.000 ReferenceFeedbackUnit	Parameter type: Range	2-setup: All setups
Conversion index: -3	Data type: u_int32	Change during operation: True

Enter the kinetic back-up trip recovery level for the application. This recovery level is the minimum speed of the motor at which the drive is to ramp up the speed.

Table 241: Range:

Min: 0	Max: 60000.000 ReferenceFeedbackUnit	Default value: 200.000 ReferenceFeedbackUnit
--------	--------------------------------------	--

4.11.3 14-2* Reset Functions

Parameters for configuring auto reset handling, special trip handling and control card self-test or initialization.

14-20 Reset Mode

Default value: [0] Manual reset	Parameter type: Option	2-setup: All setups
Conversion index: -	Data type: u_int8	Change during operation: True

Define whether the drive waits for a manual reset, or resets itself automatically after tripping. In manual reset mode, press [RESET] or use digital inputs to reset the drive.

NOTICE

In automatic reset mode, the motor can start without a warning.

Table 242: Option:

[0]	Manual reset	Select [0] <i>Manual reset</i> to reset the drive via [Reset] or via the digital inputs.
[1]	Automatic reset x 1	Select [1]-[12] <i>Automatic reset x 1... x20</i> to perform between 1 and 20 automatic resets after tripping.
[2]	Automatic reset x 2	
[3]	Automatic reset x 3	
[4]	Automatic reset x 4	
[5]	Automatic reset x 5	
[6]	Automatic reset x 6	
[7]	Automatic reset x 7	
[8]	Automatic reset x 8	
[9]	Automatic reset x 9	
[10]	Automatic reset x 10	

[11]	Automatic reset x 15	
[12]	Automatic reset x 20	
[13]	Infinite auto reset	Select [13] <i>Infinite Automatic Reset</i> for continuous resetting after tripping.

14-21 Automatic Restart Time

Default value: 10 s	Parameter type: Range	2-setup: All setups
Conversion index: 0	Data type: u_int16	Change during operation: True

To start the automatic reset function, enter the time interval from trip. This parameter is active when *parameter 14-20 Reset Mode* is set to [1] - [13] *Automatic reset*.

NOTICE

A value of 0 s cannot be set when *parameter 14-20 Reset Mode* is set to option [13] *Infinite auto reset*.

Table 243: Range:

Min: 0 s	Max: 600 s	Default value: 10 s
----------	------------	---------------------

14-22 Operation Mode

Default value: [0] Normal operation	Parameter type: Option	2-setup: 1 setup
Conversion index: -	Data type: u_int8	Change during operation: True

To reset all parameter values to default, select [2] *Initialisation*.

Table 244: Option:

[0]	Normal operation	Select [0] <i>Normal operation</i> for normal operation of the drive with the motor in the selected application.
[2]	Initialisation	Select [2] <i>Initialisation</i> to reset all parameter values to default settings, excluding bus communication parameters, <i>parameter group 15-0* Operating Data</i> , and <i>parameter group 15-3* Alarm Log</i> . The drive is reset during the next power-up. <i>Parameter 14-22 Operation Mode</i> also reverts to the default setting [0] <i>Normal operation</i> .

14-23 Typecode Setting

Default value: 0	Parameter type: Range	2-setup: 1 setup
Conversion index: 0	Data type: u_int8	Change during operation: False

Service use only.

Table 245: Range:

Min: 0	Max: 255	Default value: 0
--------	----------	------------------

14-27 Action At Inverter Fault

Default value: [1] Warning	Parameter type: Option	2-setup: All setups
Conversion index: -	Data type: u_int8	Change during operation: True

Select how the drive acts in the case of overvoltage, overcurrent, short circuit, or grounding errors.

Table 246: Option:

[0]	Trip	Disable the protection filters and trip at the 1st fault.
[1]	Warning	Run the protection filters normally.

14-28 Production Settings

Default value: [0] No action	Parameter type: Option	2-setup: 1 setup
Conversion index: -	Data type: u_int8	Change during operation: False

Service use only.

Table 247: Option:

[0]	No action
[1]	Service reset
[3]	Software Reset

14-29 Service Code

Default value: 0	Parameter type: Range	2-setup: 1 setup
Conversion index: 0	Data type: u_int32	Change during operation: True

Service use only.

Table 248: Range:

Min: 0	Max: 2147483647	Default value: 0
--------	-----------------	------------------

4.11.4 14-3* Current Limit Ctrl.

Parameters for configuring the current limit controller, which is activated when the motor current exceeds the preset current limits (see *parameter 4-18 Current Limit*). These parameters are used to reduce torque as quickly as possible without losing control of the motor.

14-30 Current Lim Ctrl, Proportional Gain

Default value: 100%	Parameter type: Range	2-setup: All setups
Conversion index: 0	Data type: u_int16	Change during operation: True

Enter the proportional gain value for the current limit controller. A higher value makes the controller react faster. Excessive value setting leads to controller instability.

Table 249: Range:

Min: 0%	Max: 500%	Default value: 100%
---------	-----------	---------------------

14-31 Current Lim Ctrl, Integration Time

Default value: 0.020 s	Parameter type: Range	2-setup: All setups
Conversion index: -3	Data type: u_int16	Change during operation: True

Control the current limit control integration time. Setting it to a lower value makes it react faster. A setting too low leads to control instability.

Table 250: Range:

Min: 0.002 s	Max: 2 s	Default value: 0.020 s
--------------	----------	------------------------

14-32 Current Lim Ctrl, Filter Time

Default value: 26.0 ms	Parameter type: Range	2-setup: All setups
Conversion index: -1	Data type: u_int16	Change during operation: True

Set a time constant for the current limit controller low-pass filter. A shorter period makes the control react faster to changes in current.

Table 251: Range:

Min: 1 ms	Max: 100 ms	Default value: 26.0 ms
-----------	-------------	------------------------

4.11.5 14-4* Energy Optimization

Parameters for adjusting the energy optimization level in both variable torque (VT) and automatic energy optimization (AEO) mode. Automatic energy optimization is only active if *parameter 1-03 Torque Characteristics* is set to [3] *Auto Energy Optim.*

14-40 VT Level

Default value: 90%	Parameter type: Range	2-setup: All setups
Conversion index: 0	Data type: u_int8	Change during operation: False

Enter the level of motor magnetization at low speed. Low values reduce energy loss in the motor, but also reduce load capability.

Table 252: Range:

Min: 40%	Max: 90%	Default value: 90%
----------	----------	--------------------

14-41 AEO Minimum Magnetisation

Default value: 66%	Parameter type: Range	2-setup: All setups
Conversion index: 0	Data type: u_int8	Change during operation: False

Enter the minimum allowable magnetization for AEO. Low values reduce energy loss in the motor, but also reduce resistance to sudden load changes.

Table 253: Range:

Min: 40%	Max: 75%	Default value: 66%
----------	----------	--------------------

14-44 d-axis current optimization for IPM

Default value: 100%	Parameter type: Range	2-setup: All setups
Conversion index: 0	Data type: u_int8	Change during operation: True

This parameter is available only when *parameter 1-10 Motor Construction* is set to [2] *PM, salient IPM, non-Sat*. Normally, VVC⁺ PM control automatically optimizes d-axis demagnetizing current based on d-axis and q-axis settings. When *parameter 1-10 Motor Construction* is set to [2] *PM, salient IPM, non-Sat*, use this parameter to compensate the saturation effect at high load. Usually, decreasing this value improves the efficiency. However, 0% means no optimization and the d-axis current is 0 (this is not recommended).

Table 254: Range:

Min: 0%	Max: 200%	Default value: 100%
---------	-----------	---------------------

4.11.6 14-5* Environment

These parameters help the drive to operate under special environmental conditions.

14-50 RFI Filter

Default value: [1] On	Parameter type: Option	2-setup: 1 setup
Conversion index: -	Data type: u_int8	Change during operation: False

This parameter is only valid for drives of the following enclosure sizes:

- IP20, 3x380–480 V, enclosure sizes H6–H8.

Table 255: Option:

[0]	Off	Select [0] Off only if the drive is fed by an isolated mains source (IT mains). In this mode, the internal RFI filter capacitors between chassis and the mains RFI filter circuit are cut out to reduce the ground capacity currents.
[1]	On	Select [1] On to ensure that the drive complies with EMC standards.

14-51 DC-Link Voltage Compensation

Default value: [1] On	Parameter type: Option	2-setup: All setups
Conversion index: -	Data type: u_int8	Change during operation: False

Enable the DC-link compensation to reduce ripple in the DC-link voltage (recommended for most applications).

Table 256: Option:

[0]	Off
[1]	On

14-52 Fan Control

Default value: [0] Auto	Parameter type: Option	2-setup: 1 setup
Conversion index: -	Data type: u_int8	Change during operation: True

This parameter is used to select the fan control operating mode. The acoustic noise of the drive is different from running heavy load (high heat sink temperature) to running light load or stand-by mode.

Table 257: Option:

[0]	Auto	The fan runs with full speed for a short time and then automatically adjusts the speed according to the load and ambient temperature. The fan also runs at minimum speed even if the reference is 0 Hz due to the heat generated from the IGBT. The fan stops if sleep mode function is activated. This is the default setting for all drives except H1 enclosure sizes.
[4]	Auto Low Temp Env.	Only valid for H6-H8 enclosure sizes.
[5]	Constant-on mode	For on-site fan test or if the fan must run 100% speed constantly. Only valid for H1- H5 enclosure sizes.
[6]	Constant-off mode	If convection cooling is sufficient or if the drive is mounted in a demonstration panel, exhibitions, and so on. The drive trips on heat sink overtemperature if loaded more than the convection cooling allows. Only valid for H1-H5 enclosure sizes.
[7]	On-when-Inverter-is-on-else-off Mode	The fan runs at maximum speed if in hand-on mode or reference is above 0 Hz. The fan is stopped if sleep mode is active. This is the default setting for H1 enclosure size only but can also be selected for H2-H5 enclosure sizes.

14-53 Fan Monitor

Default value: [1] Warning	Parameter type: Option	2-setup: 1 setup
Conversion index: -	Data type: u_int8	Change during operation: True

Select which reaction the drive should take in case a fan fault is detected. This parameter is only valid for drives of the following enclosure sizes:

- IP20, 3x380–480 V, enclosure sizes H6–H8.

Table 258: Option:

[0]	Disabled
[1]	Warning
[2]	Trip

14-55 Output Filter

Default value: [0] No filter	Parameter type: Option	2-setup: 1 setup
Conversion index: -	Data type: u_int8	Change during operation: False

Select the type of connected output filter.

Table 259: Option:

[0]	No filter	No filter is selected.
[1]	Sine-wave filter	For backwards compatibility only.
[3]	Sine-wave filter with feedback	Sine wave filter with feedback is selected.
[4]	dv/dt	This option is only valid for drives of the following enclosure sizes: <ul style="list-style-type: none"> IP20, 3x380–480 V, enclosure sizes H6–H8.

4.11.7 14-6* Auto Derate

Parameter group for configuring automatic derating based on the output frequency of the drive.

14-61 Function at Inverter Overload

Default value: [0] Trip	Parameter type: Option	2-setup: All setups
Conversion index: -	Data type: u_int8	Change during operation: True

When the drive issues an inverter overload warning, select whether to continue and probably trip the drive or derate the output current.

Table 260: Option:

[0]	Trip
[1]	Derate

14-63 Min Switch Frequency

Default value: [2] 2.0 kHz	Parameter type: Option	2-setup: 1 setup
Conversion index: -	Data type: u_int8	Change during operation: False

Set the lowest switch frequency allowed by the application.

Table 261: Option:

[2]	2.0 kHz
[3]	3.0 kHz
[4]	4.0 kHz
[5]	5.0 kHz
[6]	6.0 kHz
[7]	8.0 kHz

[8]	10.0 kHz
[9]	12.0 kHz
[10]	16.0 kHz

14-64 Dead Time Compensation Zero Current Level

Default value: [0] Disabled	Parameter type: Option	2-setup: All setups
Conversion index: -	Data type: u_int8	Change during operation: False

If a long motor cable is used, set the parameter to [1] *Enabled* to minimize the motor-torque ripple.

Table 262: Option:

[0]	Disabled
[1]	Enabled

14-65 Speed Derate Dead Time Compensation

Default value: Configuration dependent	Parameter type: Range	2-setup: All setups
Conversion index: 0	Data type: u_int16	Change during operation: False

Dead-time compensation level is reduced linearly from the maximum level of the output frequency set in *parameter 14-07 Dead Time Compensation Level* to the minimum level of the output frequency set in this parameter.

Table 263: Range:

Min: 20 Hz	Max: 1000 Hz	Default value: Configuration dependent
------------	--------------	--

4.11.8 14-9* Fault Settings

The parameter group for fault customization settings.

14-90 Fault Level

Default value: [3] Trip lock	Parameter type: Option	2-setup: 1 setup
Conversion index: -	Data type: u_int8	Change during operation: False

Use this parameter to customize fault levels. Only index 7, which indicates overcurrent faults, is supported.

Table 264: Option:

[3]	Trip lock	Alarm is set to trip lock level.
[4]	Trip w. delayed reset	Alarm is configured into trip alarm, which can be reset after a delay time. For example, if overcurrent alarm is configured to this option, it can be reset 3 minutes after the alarm is reported.
[5]	Flystart	The drive tries to catch a motor spinning when starting. If this option is selected, <i>parameter 1-73 Flying Start</i> is set to [1] <i>Enabled</i> .

4.12 Parameter Group 15-** Drive Information

Parameter group containing drive information such as operating data, hardware configuration, and software versions.

4.12.1 15-0* Operating Data

15-00 Operating hours

Default value: 0 h	Parameter type: Range	2-setup: 1 setup
Conversion index: -	Data type: u_int32	Change during operation: True

View how many hours the drive has run. The value is saved when the drive is turned off.

Table 265: Range:

Min: 0 h	Max: 2147483647 h	Default value: 0 h
----------	-------------------	--------------------

15-01 Running Hours

Default value: 0 h	Parameter type: Range	2-setup: 1 setup
Conversion index: -	Data type: u_int32	Change during operation: True

View how many hours the motor has run. Reset the counter in *parameter 15-07 Reset Running Hours Counter*. The value is saved when the drive is turned off.

Table 266: Range:

Min: 0 h	Max: 2147483647 h	Default value: 0 h
----------	-------------------	--------------------

15-02 kWh Counter

Default value: 0 kWh	Parameter type: Range	2-setup: 1 setup
Conversion index: -	Data type: u_int32	Change during operation: True

View the output power of the drive in kWh as a mean value over 1 hour. Reset the counter in *parameter 15-06 Reset kWh Counter*.

Table 267: Range:

Min: 0 kWh	Max: 65535 kWh	Default value: 0 kWh
------------	----------------	----------------------

15-03 Power Up's

Default value: 0	Parameter type: Range	2-setup: 1 setup
Conversion index: -	Data type: u_int32	Change during operation: True

View the number of times the drive has been powered up.

Table 268: Range:

Min: 0	Max: 2147483647	Default value: 0
--------	-----------------	------------------

15-04 Over Temp's

Default value: 0	Parameter type: Range	2-setup: 1 setup
Conversion index: -	Data type: u_int16	Change during operation: True

View the number of drive temperature faults that have occurred.

Table 269: Range:

Min: 0	Max: 65535	Default value: 0
--------	------------	------------------

15-05 Over Volt's

Default value: 0	Parameter type: Range	2-setup: 1 setup
Conversion index: -	Data type: u_int16	Change during operation: True

View the number of drive overvoltages that have occurred.

Table 270: Range:

Min: 0	Max: 65535	Default value: 0
--------	------------	------------------

15-06 Reset kWh Counter

Default value: [0] Do not reset	Parameter type: Option	2-setup: 1 setup
Conversion index: -	Data type: u_int8	Change during operation: True

Table 271: Option:

[0]	Do not reset	Do not reset.
[1]	Reset counter	Select this option and press [OK] to reset the kWh counter to 0 (see <i>parameter 15-02 kWh Counter</i>).

15-07 Reset Running Hours Counter

Default value: [0] Do not reset	Parameter type: Option	2-setup: 1 setup
Conversion index: -	Data type: u_int8	Change during operation: True

Table 272: Option:

[0]	Do not reset	Do not reset.
[1]	Reset counter	Select this option and press [OK] to reset the running hours counter to 0 (see <i>parameter 15-01 Running Hours</i>).

4.12.2 15-3* Alarm Log

Parameters in this group are array parameters, where up to 10 fault logs can be viewed. [0] is the most recent logged data, and [9] the oldest. Fault codes, values, and time stamp can be viewed for all logged data.

15-30 Alarm Log: Error Code

Default value: 0	Parameter type: Range	2-setup: 1 setup
Conversion index: 0	Data type: u_int16	Change during operation: True

View the fault code and lookup its meaning in *chapter Troubleshooting*.

Table 273: Range:

Min: 0	Max: 255	Default value: 0
--------	----------	------------------

15-31 InternalFaultReason

Default value: 0	Parameter type: Range	2-setup: 1 setup
Conversion index: 0	Data type: int16	Change during operation: True

View a description of the error. This parameter is used with *alarm 38, Internal Fault*.

Table 274: Range:

Min: -32767	Max: 32767	Default value: 0
-------------	------------	------------------

15-32 Alarm Log: Time

Default value: 0 s	Parameter type: Range	2-setup: All setups
Conversion index: 0	Data type: u_int32	Change during operation: False

View the time when the logged event occurred. Time is measured in seconds from the drive start-up.

Table 275: Range:

Min: 0 s	Max: 2147483647	Default value: 0 s
----------	-----------------	--------------------

4.12.3 15-4* Drive Identification

Parameters containing read-only information about the hardware and software configuration of the drive.

15-40 FC Type

Default value: 0	Parameter type: Range	2-setup: 1 setup
Conversion index: 0	Data type: VisibleString	Change during operation: False

View the FC type code. The readout is identical to the drive series power field of the type code definition, characters 1–6.

Table 276: Range:

Min: 0	Max: 6	Default value: 0
--------	--------	------------------

15-41 Power Section

Default value: 0	Parameter type: Range	2-setup: 1 setup
Conversion index: 0	Data type: VisibleString	Change during operation: False

View the FC type code. The readout is identical to the drive series power field of the type code definition, characters 7–10.

Table 277: Range:

Min: 0	Max: 20	Default value: 0
--------	---------	------------------

15-42 Voltage

Default value: 0	Parameter type: Range	2-setup: 1 setup
Conversion index: 0	Data type: VisibleString	Change during operation: False

View the FC type code. The readout is identical to the drive series power field of the type code definition, characters 11–12.

Table 278: Range:

Min: 0	Max: 20	Default value: 0
--------	---------	------------------

15-43 Software Version

Default value: 0	Parameter type: Range	2-setup: 1 setup
Conversion index: 0	Data type: VisibleString	Change during operation: False

View the software version of the drive.

Table 279: Range:

Min: 0	Max: 0	Default value: 0
--------	--------	------------------

15-44 Ordered TypeCode

Default value: 0	Parameter type: Range	2-setup: 1 setup
Conversion index: 0	Data type: VisibleString	Change during operation: False

View the type code string used for reordering the drive in its original configuration.

Table 280: Range:

Min: 0	Max: 40	Default value: 0
--------	---------	------------------

15-45 Actual Typecode String

Default value: 0	Parameter type: Range	2-setup: All setups
Conversion index: 0	Data type: VisibleString	Change during operation: False

View the actual type code string.

Table 281: Range:

Min: 0	Max: 40	Default value: 0
--------	---------	------------------

15-46 Drive Ordering No

Default value: 0	Parameter type: Range	2-setup: 1 setup
Conversion index: 0	Data type: VisibleString	Change during operation: False

View the 8-digit ordering number for reordering the drive in its original configuration.

Table 282: Range:

Min: 0	Max: 8	Default value: 0
--------	--------	------------------

15-48 LCP Id No

Default value: 0	Parameter type: Range	2-setup: 1 setup
Conversion index: 0	Data type: VisibleString	Change during operation: False

View the LCP ID number.

Table 283: Range:

Min: 0	Max: 0	Default value: 0
--------	--------	------------------

15-49 SW ID Control Card

Default value: 0	Parameter type: Range	2-setup: 1 setup
Conversion index: 0	Data type: VisibleString	Change during operation: False

View the control card software version number.

Table 284: Range:

Min: 0	Max: 0	Default value: 0
--------	--------	------------------

15-50 SW ID Power Card

Default value: 0	Parameter type: Range	2-setup: 1 setup
Conversion index: 0	Data type: VisibleString	Change during operation: False

View the power card software version number.

Table 285: Range:

Min: 0	Max: 0	Default value: 0
--------	--------	------------------

15-51 Drive Serial Number

Default value: 0	Parameter type: Range	2-setup: 1 setup
Conversion index: 0	Data type: VisibleString	Change during operation: False

View the drive serial number.

Table 286: Range:

Min: 0	Max: 10	Default value: 0
--------	---------	------------------

15-52 OEM Information

Default value: 0	Parameter type: Range	2-setup: 1 setup
Conversion index: 0	Data type: VisibleString	Change during operation: False

OEM Information. [0] means OEM name. [1] means OEM type code. [2] means OEM identification number. [3] means OEM serial number.

Table 287: Range:

Min: 0	Max: 0	Default value: 0
--------	--------	------------------

15-53 Power Card Serial Number

Default value: 0	Parameter type: Range	2-setup: 1 setup
Conversion index: 0	Data type: VisibleString	Change during operation: False

View the power card serial number.

Table 288: Range:

Min: 0	Max: 0	Default value: 0
--------	--------	------------------

15-57 File Version

Default value: 0	Parameter type: Range	2-setup: 1 setup
Conversion index: 0	Data type: u_int16	Change during operation: False

The file version. [0] means OEM-SIVP file version. [1] means Motor database file version. [2] means Pump table file version.[3] means ACP boot file version. [4] means MCP boot file version.

Table 289: Range:

Min: 0	Max: 65535	Default value: 0
--------	------------	------------------

15-59 Filename

Default value: 0	Parameter type: Range	2-setup: 1 setup
Conversion index: 0	Data type: VisibleString	Change during operation: False

The actual file name of OEM files.

Table 290: Range:

Min: 0	Max: 16	Default value: 0
--------	---------	------------------

4.12.4 15-9* Parameter Info

View information of available parameters in the drive.

15-92 Defined Parameters

Default value: 0	Parameter type: Range	2-setup: 1 setup
Conversion index: 0	Data type: u_int16	Change during operation: True

View a list of all defined parameters in the drive. The list ends with 0.

Table 291: Range:

Min: 0	Max: 2000	Default value: 0
--------	-----------	------------------

15-97 Application Type

Default value: 0	Parameter type: Range	2-setup: 1 setup
Conversion index: 0	Data type: u_int32	Change during operation: True

This parameter contains data used by the MCT10 software tool.

Table 292: Range:

Min: 0	Max: 4294967295	Default value: 0
--------	-----------------	------------------

15-98 Drive Identification

Default value: 0	Parameter type: Range	2-setup: 1 setup
Conversion index: 0	Data type: VisibleString	Change during operation: False

This parameter contains data used by the MCT10 software tool.

Table 293: Range:

Min: 0	Max: 56	Default value: 0
--------	---------	------------------

4.13 Parameter Group 16-** Data Readouts

4.13.1 16-0* General Status

Parameters for reading the general status, for example, the calculated reference, the active control word, and status.

16-00 Control Word

Default value: 0	Parameter type: Range	2-setup: 1 setup
Conversion index: 0	Data type: u_int16	Change during operation: True

View the control word sent from the drive via the serial communication port in hex code.

Table 294: Control Word

Bit	Bit=0	Bit=1
00	Preset reference option lsb	–
01	Preset reference option 2 nd bit of preset references	–
02	DC brake	Ramp
03	Coasting	Enable
04	Quick stop	Ramp
05	Freeze output	Ramp
06	Ramp stop	Start
07	No function	Reset
08	No function	Jog
09	Ramp 1	Ramp 2
10	Data not valid	Valid

Bit	Bit=0	Bit=1
11	Relay_A not active	Relay_A active
12	Relay_B not active	Relay_B active
13	Choice of setup lsb	–
14	No function	No function
15	No function	Reversing

Table 295: Range:

Min: 0	Max: 65535	Default value: 0
--------	------------	------------------

16-01 Reference [Unit]

Default value: 0 ReferenceFeedbackUnit	Parameter type: Range	2-setup: 1 setup
Conversion index: -3	Data type: int32	Change during operation: True

View the present reference value applied on impulse or analog basis in the unit resulting from the configuration selected in *parameter 1-00 Configuration Mode (Hz)*.

Table 296: Range:

Min: -4999	Max: -4999 ReferenceFeedbackUnit	Default value: 0 ReferenceFeedbackUnit
------------	----------------------------------	--

16-02 Reference [%]

Default value: 0.0%	Parameter type: Range	2-setup: 1 setup
Conversion index: -1	Data type: int16	Change during operation: True

View the total reference. The total reference is the sum of digital, analog, preset, bus, and freeze references.

Table 297: Range:

Min: -200.0%	Max: 200.0%	Default value: 0.0%
--------------	-------------	---------------------

16-03 Status Word

Default value: 0	Parameter type: Range	2-setup: 1 setup
Conversion index: 0	Data type: u_int16	Change during operation: True

View the status word sent from the drive via the serial communication port in hex code.

Table 298: Control Word

Bit	Bit=0	Bit=1
00	Control not ready	Ready
01	VLT not ready	Ready
02	Coasting	Enable
03	No fault	Trip
04	No warning	Warning
05	Reserved	–
06	No trip lock	Trip lock

Bit	Bit=0	Bit=1
07	No warning	Warning
08	Speed ≠ ref.	Speed = ref.
09	Local control	Bus control
10	Out of range	Frequency OK
11	Not running	Running
12	No function	No function
13	Voltage OK	Above limit
14	Current OK	Above limit
15	Thermal-level OK	Above limit

Table 299: Range:

Min: 0	Max: 65535	Default value: 0
--------	------------	------------------

16-05 Main Actual Value [%]

Default value: 0%	Parameter type: Range	2-setup: 1 setup
Conversion index: -2	Data type: int16	Change during operation: True

View the 2 byte word sent with the status word to the bus master reporting the main actual value.

Table 300: Range:

Min: -200%	Max: 200%	Default value: 0%
------------	-----------	-------------------

16-09 Custom Readout

Default value: 0 CustomReadoutUnit	Parameter type: Range	2-setup: 1 setup
Conversion index: -2	Data type: int32	Change during operation: True

View the user-defined readouts as defined in *parameter 0-30 Custom Readout Unit*, *parameter 0-31 Custom Readout Min Value*, and *parameter 0-32 Custom Readout Max Value*.

Table 301: Range:

Min: 0	Max: 9999 CustomReadoutUnit	Default value: 0 CustomReadoutUnit
--------	-----------------------------	------------------------------------

4.13.2 16-1* Motor Status

Parameters for reading the motor status values.

16-10 Power [kW]

Default value: 0 kW	Parameter type: Range	2-setup: 1 setup
Conversion index: -3	Data type: u_int32	Change during operation: True

Display the actual motor power in kW. The value shown is calculated on the basis of the actual DC-link voltage and DC-link current.

Table 302: Range:

Min: 0 kW	Max: 1000 kW	Default value: 0 kW
-----------	--------------	---------------------

16-11 Power [hp]

Default value: 0 hp	Parameter type: Range	2-setup: 1 setup
Conversion index: -3	Data type: u_int32	Change during operation: True

View the actual motor power in hp. The value shown is calculated based on the actual DC-link voltage and DC-link current.

Table 303: Range:

Min: 0 hp	Max: 1000 hp	Default value: 0 hp
-----------	--------------	---------------------

16-12 Motor Voltage

Default value: 0 V	Parameter type: Range	2-setup: 1 setup
Conversion index: 0	Data type: u_int32	Change during operation: True

View the motor voltage, a calculated value used for controlling the motor.

Table 304: Range:

Min: 0 V	Max: 65535 V	Default value: 0 V
----------	--------------	--------------------

16-13 Frequency

Default value: 0 Hz	Parameter type: Range	2-setup: 1 setup
Conversion index: -1	Data type: u_int32	Change during operation: True

View the motor frequency, without resonance damping.

Table 305: Range:

Min: 0 Hz	Max: 6553.5 Hz	Default value: 0 Hz
-----------	----------------	---------------------

16-14 Motor current

Default value: 0 A	Parameter type: Range	2-setup: 1 setup
Conversion index: -2	Data type: u_int16	Change during operation: True

View the motor current measured as an average value, I_{RMS} .

Table 306: Range:

Min: 0 A	Max: 655.35 A	Default value: 0 A
----------	---------------	--------------------

NOTICE

The maximum display value is 655.35 A, if the actual motor current surpasses 655.35 A, the data can be viewed from *parameter 18-88 Motor current*.

16-15 Frequency [%]

Default value: 0%	Parameter type: Range	2-setup: 1 setup
Conversion index: -1	Data type: u_int16	Change during operation: True

View the actual motor frequency as a percentage of *parameter 4-14 Motor Speed High Limit*.

Table 307: Range:

Min: 0%	Max: 6553.5%	Default value: 0%
---------	--------------	-------------------

16-16 Torque [Nm]

Default value: 0 Nm	Parameter type: Range	2-setup: All setups
Conversion index: -1	Data type: int32	Change during operation: False

View the torque value that is applied on the motor shaft. Some motors supply more than 160% torque. Consequently, the minimum value and the maximum value depend on the minimum/maximum motor current as well as the motor used.

Table 308: Range:

Min: -30000 Nm	Max: 30000 Nm	Default value: 0 Nm
----------------	---------------	---------------------

16-17 Speed [RPM]

Default value: 0 RPM	Parameter type: Range	2-setup: 1 setup
Conversion index: 0	Data type: int32	Change during operation: False

View the actual motor RPM. The motor RPM is estimated in open-loop process or closed-loop process control modes and the motor RPM is measured in speed closed-loop mode.

Table 309: Range:

Min: -30000 RPM	Max: 30000 RPM	Default value: 0 RPM
-----------------	----------------	----------------------

16-18 Motor Thermal

Default value: 0%	Parameter type: Range	2-setup: 1 setup
Conversion index: 0	Data type: u_int8	Change during operation: True

View the calculated motor temperature in percentage of allowed maximum. At 100%, a trip occurs if selected in *parameter 1-90 Motor Thermal Protection*. The basis for the calculation is the ETR function selected in *parameter 1-90 Motor Thermal Protection*.

Table 310: Range:

Min: 0%	Max: 100%	Default value: 0%
---------	-----------	-------------------

16-22 Torque [%]

Default value: 0%	Parameter type: Range	2-setup: All setups
Conversion index: 0	Data type: int16	Change during operation: False

View the torque in percentage (in relation to the nominal torque) that is applied to the motor shaft.

Table 311: Range:

Min: -200%	Max: 200%	Default value: 0%
------------	-----------	-------------------

16-26 Power Filtered [kW]

Default value: 0 kW	Parameter type: Range	2-setup: 1 setup
Conversion index: -3	Data type: int32	Change during operation: False

Motor power consumption. The value shown is calculated on basis of the actual motor voltage and motor current. The value is filtered, and a few seconds may pass from when an input value changes to when the data read-out values change.

Table 312: Range:

Min: 0 kW	Max: 1000 kW	Default value: 0 kW
-----------	--------------	---------------------

16-27 Power Filtered [hp]

Default value: 0 hp	Parameter type: Range	2-setup: 1 setup
Conversion index: -3	Data type: int32	Change during operation: False

Motor power in hp. The value shown is calculated on the basis of actual motor voltage and motor current. The value is filtered, and a few seconds may pass from when an input value changes to when the data read-out values change.

Table 313: Range:

Min: 0 hp	Max: 1000 hp	Default value: 0 hp
-----------	--------------	---------------------

4.13.3 16-3* Drive Status

16-30 DC Link Voltage

Default value: 0 V	Parameter type: Range	2-setup: 1 setup
Conversion index: 0	Data type: u_int32	Change during operation: True

Show the actual DC-link voltage.

Table 314: Range:

Min: 0 V	Max: 65535 V	Default value: 0 V
----------	--------------	--------------------

16-34 Heatsink Temp.

Default value: 0°C	Parameter type: Range	2-setup: 1 setup
Conversion index: 0	Data type: int8	Change during operation: True

View the heat sink temperature of the drive.

Table 315: Range:

Min: -128°C	Max: 127°C	Default value: 0°C
-------------	------------	--------------------

16-35 Inverter Thermal

Default value: 0%	Parameter type: Range	2-setup: 1 setup
Conversion index: 0	Data type: u_int8	Change during operation: True

View the percentage of thermal load on the drive. At 100%, a trip occurs.

Table 316: Range:

Min: 0%	Max: 255%	Default value: 0%
---------	-----------	-------------------

16-36 Inv. Nom. Current

Default value: 0 A	Parameter type: Range	2-setup: 1 setup
Conversion index: -2	Data type: u_int16	Change during operation: True

View the inverter nominal current. The data is used for motor overload protection and so on.

Table 317: Range:

Min: 0 A	Max: 655.35 A	Default value: 0 A
----------	---------------	--------------------

16-37 Inv. Max. Current

Default value: 0 A	Parameter type: Range	2-setup: 1 setup
Conversion index: -2	Data type: u_int16	Change during operation: True

View the inverter maximum current. The data is used for calculation of drive protection and so on.

Table 318: Range:

Min: 0 A	Max: 655.35 A	Default value: 0 A
----------	---------------	--------------------

N O T I C E

The maximum display value is 655.35 A, if the actual drive inverter maximum current surpasses 655.35 A, the data can be viewed from *parameter 18-87 Inv. Max. Current*.

16-38 SL Controller State

Default value: 0	Parameter type: Range	2-setup: 1 setup
Conversion index: 0	Data type: u_int8	Change during operation: True

View the actual state of the smart logic controller (SLC).

Table 319: Range:

Min: 0	Max: 20	Default value: 0
--------	---------	------------------

4.13.4 16-5* Ref. & Feedb.

16-50 External Reference

Default value: 0%	Parameter type: Range	2-setup: 1 setup
Conversion index: -1	Data type: int16	Change during operation: True

View the total reference, the sum of digital, analog, preset, bus, and freeze references.

Table 320: Range:

Min: -200%	Max: 200%	Default value: 0%
------------	-----------	-------------------

16-52 Feedback[Unit]

Default value: 0 ProcessCtrlUnit	Parameter type: Range	2-setup: 1 setup
Conversion index: -3	Data type: int32	Change during operation: True

View the feedback resulting from the selection of scaling in *parameter 3-02 Minimum Reference* and *parameter 3-03 Maximum Reference*.

Table 321: Range:

Min: -4999	Max: 4999 ProcessCtrlUnit	Default value: 0 ProcessCtrlUnit
------------	---------------------------	----------------------------------

16-54 Feedback 1 [Unit]

Default value: 0 ProcessCtrlUnit	Parameter type: Range	2-setup: All setups
Conversion index: -3	Data type: int32	Change during operation: True

View the feedback 1 value resulting from the selection of scaling in *parameter 3-02 Minimum Reference* and *parameter 3-03 Maximum Reference* and selection of unit in *parameter 20-12 Reference/Feedback Unit*.

Table 322: Range:

Min: -999999.999	Max: 999999.999 ProcessCtrlUnit	Default value: 0 ProcessCtrlUnit
------------------	---------------------------------	----------------------------------

16-55 Feedback 2 [Unit]

Default value: 0 ProcessCtrlUnit	Parameter type: Range	2-setup: All setups
Conversion index: -3	Data type: int32	Change during operation: False

View the feedback 2 value resulting from the selection of scaling in *parameter 3-02 Minimum Reference* and *parameter 3-03 Maximum Reference* and selection of unit in *parameter 20-12 Reference/Feedback Unit*.

Table 323: Range:

Min: -999999.999	Max: 999999.999 ProcessCtrlUnit	Default value: 0 ProcessCtrlUnit
------------------	---------------------------------	----------------------------------

16-56 Feedback 3 [Unit]

Default value: 0 ProcessCtrlUnit	Parameter type: Range	2-setup: All setups
Conversion index: -3	Data type: int32	Change during operation: False

View the feedback 3 value resulting from the selection of scaling in *parameter 3-02 Minimum Reference* and *parameter 3-03 Maximum Reference* and selection of unit in *parameter 20-12 Reference/Feedback Unit*.

Table 324: Range:

Min: -999999.999	Max: 999999.999 ProcessCtrlUnit	Default value: 0 ProcessCtrlUnit
------------------	---------------------------------	----------------------------------

4.13.5 16-6* Inputs and Outputs

16-60 Digital Input

Default value: 0	Parameter type: Range	2-setup: 1 setup
Conversion index: 0	Data type: u_int16	Change during operation: True

View actual state of the digital inputs.

Table 325: Bit Definitions

Bit 0	Unused
Bit 1	Unused
Bit 2	Digital input terminal 29
Bit 3	Digital input terminal 27
Bit 4	Digital input terminal 19
Bit 5	Digital input terminal 18
Bit 6–15	Unused

Table 326: Range:

Min: 0	Max: 4095	Default value: 0
--------	-----------	------------------

16-61 Terminal 53 Setting

Default value: [0] Current mode	Parameter type: Option	2-setup: 1 setup
Conversion index: -	Data type: u_int8	Change during operation: True

View the setting of input terminal 53.

Table 327: Option:

[0]	Current mode
[1]	Voltage mode

16-62 Analog input 53

Default value: 1	Parameter type: Range	2-setup: 1 setup
Conversion index: -2	Data type: u_int16	Change during operation: True

View the actual value at input 53.

Table 328: Range:

Min: 0	Max: 20	Default value: 1
--------	---------	------------------

16-63 Terminal 54 Setting

Default value: [0] Current mode	Parameter type: Option	2-setup: 1 setup
Conversion index: -	Data type: u_int8	Change during operation: True

View the setting of input terminal 54.

Table 329: Option:

[0]	Current mode
[1]	Voltage mode

16-64 Analog input 54

Default value: 1	Parameter type: Range	2-setup: 1 setup
Conversion index: -2	Data type: u_int16	Change during operation: True

View the actual value at input 54.

Table 330: Range:

Min: 0	Max: 20	Default value: 1
--------	---------	------------------

16-65 Analog output 42 [mA]

Default value: 0 mA	Parameter type: Range	2-setup: 1 setup
Conversion index: -2	Data type: u_int16	Change during operation: True

View the actual value at output 42 in mA. The value shown reflects the selection in *parameter 6-90 Terminal 42 Mode* and *parameter 6-91 Terminal 42 Analog Output*.

Table 331: Range:

Min: 0 mA	Max: 20 mA	Default value: 0 mA
-----------	------------	---------------------

16-66 Digital Output

Default value: 0	Parameter type: Range	2-setup: 1 setup
Conversion index: 0	Data type: VisibleString	Change during operation: True

View the binary value of all digital outputs.

Table 332: Bit Definitions

Bit 0	Digital output terminal 27
Bit 1	Digital output terminal 29
Bit 2	Digital output terminal 42
Bit 3	Digital output terminal 45
Bit 4–15	Unused

Table 333: Range:

Min: 0	Max: 15	Default value: 0
--------	---------	------------------

16-67 Pulse Input #29 [Hz]

Default value: 0	Parameter type: Range	2-setup: All setups
Conversion index: 0	Data type: int32	Change during operation: False

View the actual value of the frequency applied at terminal 29 as a pulse input.

Table 334: Range:

Min: 0	Max: 130000	Default value: 0
--------	-------------	------------------

16-71 Relay output

Default value: 0	Parameter type: Range	2-setup: 1 setup
Conversion index: 0	Data type: u_int16	Change during operation: True

View the setting of the relay.

Table 335: Bit Definitions

Bit 0–2	Unused
Bit 3	Relay 02
Bit 4	Relay 01
Bit 5–15	Unused

Table 336: Range:

Min: 0	Max: 31	Default value: 0
--------	---------	------------------

16-72 Counter A

Default value: 0	Parameter type: Range	2-setup: 1 setup
Conversion index: 0	Data type: int16	Change during operation: True

View the present value of counter A. Counters are useful as comparator operands, see *parameter 13-10 Comparator Operand*. The value can be reset or changed either via digital inputs (*parameter group 5-1* Digital Inputs*) or by using an SLC action (*parameter 13-52 SL Controller Action*).

Table 337: Range:

Min: -32768	Max: 32767	Default value: 0
-------------	------------	------------------

16-73 Counter B

Default value: 0	Parameter type: Range	2-setup: 1 setup
Conversion index: 0	Data type: int16	Change during operation: True

View the present value of counter B. Counters are useful as comparator operands, see *parameter 13-10 Comparator Operand*. The value can be reset or changed either via digital inputs (*parameter group 5-1* Digital Inputs*) or by using an SLC action (*parameter 13-52 SL Controller Action*).

Table 338: Range:

Min: -32768	Max: 32767	Default value: 0
-------------	------------	------------------

16-79 Analog output 45 [mA]

Default value: 0 mA	Parameter type: Range	2-setup: 1 setup
Conversion index: -2	Data type: u_int16	Change during operation: True

View the actual value at output 45 in mA. The value shown reflects the selection in *parameter 6-70 Terminal 45 Mode* and *parameter 6-71 Terminal 45 Analog Output*.

Table 339: Range:

Min: 0 mA	Max: 20 mA	Default value: 0 mA
-----------	------------	---------------------

4.13.6 16-8* Fieldbus & FC Port

Parameters for reporting the bus references and control words.

16-86 FC Port REF 1

Default value: 0	Parameter type: Range	2-setup: 1 setup
Conversion index: 0	Data type: int16	Change during operation: True

View the last received reference from the FC port.

Table 340: Range:

Min: -32768	Max: 32767	Default value: 0
-------------	------------	------------------

4.13.7 16-9* Diagnosis Read-Outs

16-90 Alarm Word

Default value: 0	Parameter type: Range	2-setup: 1 setup
Conversion index: 0	Data type: u_int32	Change during operation: True

View the alarm word sent via the serial communication port in hex code.

Table 341: Range:

Min: 0	Max: 4294967295	Default value: 0
--------	-----------------	------------------

16-91 Alarm Word 2

Default value: 0	Parameter type: Range	2-setup: 1 setup
Conversion index: 0	Data type: u_int32	Change during operation: True

View the alarm word 2 sent via the serial communication port in hex code.

Table 342: Range:

Min: 0	Max: 4294967295	Default value: 0
--------	-----------------	------------------

16-92 Warning Word

Default value: 0	Parameter type: Range	2-setup: 1 setup
Conversion index: 0	Data type: u_int32	Change during operation: True

View the warning word sent via the serial communication port in hex code.

Table 343: Range:

Min: 0	Max: 4294967295	Default value: 0
--------	-----------------	------------------

16-93 Warning Word 2

Default value: 0	Parameter type: Range	2-setup: 1 setup
Conversion index: 0	Data type: u_int32	Change during operation: True

View the warning word 2 sent via the serial communication port in hex code.

Table 344: Range:

Min: 0	Max: 4294967295	Default value: 0
--------	-----------------	------------------

16-94 Ext. Status Word

Default value: 0	Parameter type: Range	2-setup: 1 setup
Conversion index: 0	Data type: u_int32	Change during operation: True

View the extended status word sent via the serial communication port in hex code.

Table 345: Range:

Min: 0	Max: 4294967295	Default value: 0
--------	-----------------	------------------

16-95 Ext. Status Word 2

Default value: 0	Parameter type: Range	2-setup: 1 setup
Conversion index: 0	Data type: u_int32	Change during operation: True

View the extended status word 2 sent via the serial communication port in hex code.

Table 346: Range:

Min: 0	Max: 4294967295	Default value: 0
--------	-----------------	------------------

16-97 Alarm Word 3

Default value: 0	Parameter type: Range	2-setup: 1 setup
Conversion index: 0	Data type: u_int32	Change during operation: True

View the alarm word 3 sent via the serial communication port in hex code.

Table 347: Range:

Min: 0	Max: 4294967295	Default value: 0
--------	-----------------	------------------

16-98 Warning Word 3

Default value: 0	Parameter type: Range	2-setup: 1 setup
Conversion index: 0	Data type: u_int32	Change during operation: True

View the warning word 3 sent via the serial communication port in hex code.

Table 348: Range:

Min: 0	Max: 4294967295	Default value: 0
--------	-----------------	------------------

4.14 Parameter Group 18-** Info & Readouts

Parameter group for drive information and data readouts.

4.14.1 18-1* Fire Mode Log

View up to 10 latest faults, that have been suppressed during Fire Mode. [0] is the most recent logged data, and [9] the oldest. Error codes, values, and time stamp can be viewed for all logged data.

18-10 FireMode Log:Event

Default value: 0	Parameter type: Range	2-setup: 1 setup
Conversion index: 0	Data type: u_int8	Change during operation: True

View fire mode event.

Table 349: Range:

Min: 0	Max: 255	Default value: 0
--------	----------	------------------

4.14.2 18-5* Ref. & Feedb.

Parameters for reporting the reference and feedback input.

18-50 Sensorless Readout [unit]

Default value: 0 SensorlessUnit	Parameter type: Range	2-setup: 1 setup
Conversion index: -3	Data type: int32	Change during operation: False

View the pressure or flow resulting from the sensorless calculations. This value is not the value used for control. The value is only updated if sensorless data supports both flow and pressure.

Table 350: Range:

Min: -999999.999	Max: 999999.999 SensorlessUnit	Default value: 0 SensorlessUnit
------------------	--------------------------------	---------------------------------

4.14.3 18-8* Compatibility

18-87 Inv. Max. Current

Default value: 0.00 A	Parameter type: Range	2-setup: All setups
Conversion index: -2	Data type: u_int32	Change during operation: True

View the inverter maximum current. This data is used for calculation of drive protection and so on.

Table 351: Range:

Min: 0.00 A	Max: 9999.99 A	Default value: 0.00 A
-------------	----------------	-----------------------

18-88 Motor current

Default value: 0.00 A	Parameter type: Range	2-setup: All setups
Conversion index: -2	Data type: u_int32	Change during operation: True

View the motor current measured as a mean value I_{rms} .

Table 352: Range:

Min: 0.00 A	Max: 9999.99 A	Default value: 0.00 A
-------------	----------------	-----------------------

4.14.4 18-9* PID Readouts

18-90 Process PID Error

Default value: 0.0%	Parameter type: Range	2-setup: All setups
Conversion index: -1	Data type: int16	Change during operation: False

View the error value in the process PID controller.

Table 353: Range:

Min: -200.0%	Max: 200.0%	Default value: 0.0%
--------------	-------------	---------------------

18-91 Process PID Output

Default value: 0.0%	Parameter type: Range	2-setup: All setups
Conversion index: -1	Data type: int16	Change during operation: False

View the raw output value from the process PID controller.

Table 354: Range:

Min: -200.0%	Max: 200.0%	Default value: 0.0%
--------------	-------------	---------------------

18-92 Process PID Clamped Output

Default value: 0.0%	Parameter type: Range	2-setup: All setups
Conversion index: -1	Data type: int16	Change during operation: False

View the output value from the process PID controller after reaching a clamp limit.

Table 355: Range:

Min: -200.0%	Max: 200.0%	Default value: 0.0%
--------------	-------------	---------------------

18-93 Process PID Gain Scaled Output

Default value: 0.0%	Parameter type: Range	2-setup: All setups
Conversion index: -1	Data type: int16	Change during operation: False

View the output value from the process PID controller after reaching a clamp limit, and scaling the resulting value with considerations to the gain.

Table 356: Range:

Min: -200.0%	Max: 200.0%	Default value: 0.0%
--------------	-------------	---------------------

4.15 Parameter Group 20-** Drive Closed Loop

This parameter group is used for configuring the closed loop PI controller that controls the output frequency of the drive.

4.15.1 20-0* Feedback

This parameter group is used to configure the feedback signal for the closed-loop PI control of the drive.

20-00 Feedback 1 Source

Default value: [0] No function	Parameter type: Option	2-setup: All setups
Conversion index: -	Data type: u_int8	Change during operation: True

This parameter defines which input is used as the source of the feedback signal.

Table 357: Option:

[0]	No function
[1]	Analog input 53
[2]	Analog input 54
[3]	Pulse input 29
[100]	Bus feedback 1
[101]	Bus feedback 2
[104]	Sensorless flow
[105]	Sensorless pressure

20-01 Feedback 1 Conversion

Default value: [0] Linear	Parameter type: Option	2-setup: All setups
Conversion index: -	Data type: u_int8	Change during operation: True

This parameter allows a conversion function to be applied to feedback 1.

Table 358: Option:

[0]	Linear	[0] Linear has no effect on the feedback.
[1]	Square root	[1] Square root is commonly used when a pressure sensor is used to provide flow feedback. $\text{flow} \propto \sqrt{\text{pressure}}$

20-03 Feedback 2 Source

Default value: [0] No function	Parameter type: Option	2-setup: All setups
Conversion index: -	Data type: u_int8	Change during operation: True

The effective feedback signal is made up of up to 3 different input signals. Select which drive input should be treated as the source of the 2nd of these signals. The other input signals are defined in *parameter 20-00 Feedback 1 Source* and *parameter 20-06 Feedback 3 Source*.

Table 359: Option:

[0]	No function
[1]	Analog input 53
[2]	Analog input 54
[3]	Pulse input 29
[100]	Bus feedback 1
[101]	Bus feedback 2

20-04 Feedback 2 Conversion

Default value: [0] Linear	Parameter type: Option	2-setup: All setups
Conversion index: -	Data type: u_int8	Change during operation: False

This parameter allows a conversion function to be applied to feedback 2.

Table 360: Option:

[0]	Linear	[0] <i>Linear</i> has no effect on the feedback.
[1]	Square root	[1] <i>Square root</i> is commonly used when a pressure sensor is used to provide flow feedback. $\text{flow} \propto \sqrt{\text{pressure}}$

20-06 Feedback 3 Source

Default value: [0] No function	Parameter type: Option	2-setup: All setups
Conversion index: -	Data type: u_int8	Change during operation: True

The effective feedback signal is made up of up to 3 different input signals. Select which drive input should be treated as the source of the 2nd of these signals. The other input signals are defined in *parameter 20-00 Feedback 1 Source* and *parameter 20-03 Feedback 2 Source*.

Table 361: Option:

[0]	No function
[1]	Analog input 53
[2]	Analog input 54
[3]	Pulse input 29
[100]	Bus feedback 1
[101]	Bus feedback 2

20-07 Feedback 3 Conversion

Default value: [0] Linear	Parameter type: Option	2-setup: All setups
Conversion index: -	Data type: u_int8	Change during operation: False

This parameter allows a conversion function to be applied to feedback 3.

Table 362: Option:

[0]	Linear	[0] <i>Linear</i> has no effect on the feedback.
[1]	Square root	[1] <i>Square root</i> is commonly used when a pressure sensor is used to provide flow feedback. $\text{flow} \propto \sqrt{\text{pressure}}$

20-12 Reference/Feedback Unit

Default value: [0] None	Parameter type: Option	2-setup: All setups
Conversion index: -	Data type: u_int8	Change during operation: True

Select the unit to be used with references and feedbacks for closed loop.

Table 363: Option:

[0]	None
[20]	l/s
[23]	m ³ /s
[24]	m ³ /min

[25]	m ³ /h
[71]	bar
[73]	kPa
[74]	m Wg
[75]	mm Hg
[120]	GPM
[121]	gal/s
[122]	gal/min
[123]	gal/h
[124]	CFM
[125]	ft ³ /s
[126]	ft ³ /min
[170]	psi
[171]	lb/in ²
[172]	in WG
[173]	ft WG
[174]	in Hg

4.15.2 20-2* Feedback/Setpoint

Parameter group for feedback function and setpoints. Select which setpoint and feedback to use. The setpoint and feedback can be a fixed pair or selected separately based on logic comparisons.

20-20 Feedback Function

Default value: [3] Minimum	Parameter type: Option	2-setup: All setups
Conversion index: -	Data type: u_int8	Change during operation: True

Select how the feedback should be calculated. The feedback can be either a single feedback source or a combination of several feedbacks.

Table 364: Option:

[0]	Sum
[1]	Difference
[2]	Average
[3]	Minimum
[4]	Maximum

20-21 Setpoint 1

Default value: 0 ProcessCtrlUnit	Parameter type: Range	2-setup: All setups
Conversion index: -3	Data type: int32	Change during operation: True

Setpoint 1 is used in closed loop as the reference to compare the feedback values with. The setpoint can be offset with digital, analog, or bus references.

Table 365: Range:

Min: -4999.000	Max: 4999.000 ProcessCtrlUnit	Default value: 0 ProcessCtrlUnit
----------------	-------------------------------	----------------------------------

4.15.3 20-6* Sensorless

Parameters for sensorless. See also *parameter 16-26 Power Filtered [kW]*, *parameter 16-27 Power Filtered [hp]*, *parameter 18-50 Sensorless Readout [unit]*, and *parameter 20-00 Feedback 1 Source*.

20-60 Sensorless Unit

Default value: [20] l/s	Parameter type: Option	2-setup: All setups
Conversion index: -	Data type: u_int8	Change during operation: True

Select the unit to be used with *parameter 18-50 Sensorless Readout [unit]*.

Table 366: Option:

[0]	None
[20]	l/s
[23]	m ³ /s
[24]	m ³ /min
[25]	m ³ /h
[71]	bar
[73]	kPa
[74]	m Wg
[75]	mm Hg
[120]	GPM
[121]	gal/s
[122]	gal/min
[123]	gal/h
[124]	CFM
[125]	ft ³ /s
[126]	ft ³ /min
[170]	psi
[171]	lb/in ²
[172]	in WG
[173]	ft WG
[174]	in Hg

20-69 Sensorless Information

Default value: 0	Parameter type: Range	2-setup: 1 setup
Conversion index: 0	Data type: VisibleString	Change during operation: True

View information about the sensorless data.

Table 367: Range:

Min: 0	Max: 25	Default value: 0
--------	---------	------------------

4.15.4 20-7* PI Autotuning

Parameters for enabling PI auto-tuning.

20-70 Closed Loop Type

Default value: [0] Auto	Parameter type: Option	2-setup: 1 setup
Conversion index: -	Data type: u_int8	Change during operation: True

Select the expected application response.

Table 368: Option:

[0]	Auto
[1]	Fast pressure
[2]	Slow pressure
[3]	Fast temperature
[4]	Slow temperature

20-71 PI Performance

Default value: [0] Normal	Parameter type: Option	2-setup: 1 setup
Conversion index: -	Data type: u_int8	Change during operation: True

Select the relative response speed for the application.

Table 369: Option:

[0]	Normal
[1]	Fast

20-72 PI Output Change

Default value: 0.10	Parameter type: Range	2-setup: 1 setup
Conversion index: -2	Data type: u_int16	Change during operation: True

Set the magnitude of step change during the auto-tuning sequence.

Table 370: Range:

Min: 0.01	Max: 0.50	Default value: 0.10
-----------	-----------	---------------------

20-73 Minimum Feedback Level

Default value: -4999.000 ProcessCtrlUnit	Parameter type: Range	2-setup: 1 setup
Conversion index: -3	Data type: int32	Change during operation: True

Set the minimum allowable feedback value during the auto-tuning sequence.

Table 371: Range:

Min: -4999.000	Max: 4999.000 ProcessCtrlUnit	Default value: -4999.000 ProcessCtrlUnit
----------------	-------------------------------	--

20-74 Maximum Feedback Level

Default value: 4999.000 ProcessCtrlUnit	Parameter type: Range	2-setup: 1 setup
Conversion index: -3	Data type: int32	Change during operation: True

Set the maximum allowable feedback value during the auto-tuning sequence.

Table 372: Range:

Min: -4999.000	Max: 4999.000 ProcessCtrlUnit	Default value: 4999.000 ProcessCtrlUnit
----------------	-------------------------------	---

20-79 PI Autotuning

Default value: [0] Disabled	Parameter type: Option	2-setup: 1 setup
Conversion index: -	Data type: u_int8	Change during operation: True

Table 373: Option:

[0]	Disabled	Select to disable PI auto-tuning.
[1]	Enabled	Select to enable PI auto-tuning.

4.15.5 20-8* PI Basic Settings

20-81 PI Normal/ Inverse Control

Default value: [0] Normal	Parameter type: Option	2-setup: All setups
Conversion index: -	Data type: u_int8	Change during operation: True

Table 374: Option:

[0]	Normal	Set the process control to increase the output speed when the process error is positive.
[1]	Inverse	Reduce the output speed when the process error is positive.

20-83 PI Start Speed [Hz]

Default value: 0 Hz	Parameter type: Range	2-setup: All setups
Conversion index: -1	Data type: u_int16	Change during operation: True

Enter the motor speed to be attained as a start signal for commencement of PI control. After power-up, the drive operates using speed open-loop control. When the process PI start speed is reached, the drive changes to PI control.

Table 375: Range:

Min: 0 Hz	Max: 200.0 Hz	Default value: 0 Hz
-----------	---------------	---------------------

20-84 On Reference Bandwidth

Default value: 5%	Parameter type: Range	2-setup: All setups
Conversion index: 0	Data type: u_int8	Change during operation: True

Enter the On Reference bandwidth. When the PI Control Error (the difference between the reference and the feedback) is greater than the value of this parameter, then the On Reference status bit is set high (1).

Table 376: Range:

Min: 0%	Max: 200%	Default value: 5%
---------	-----------	-------------------

4.15.6 20-9* PI Controller

Parameters for configuring the Process PI controller.

20-91 PI Anti Windup

Default value: [1] On	Parameter type: Option	2-setup: All setups
Conversion index: -	Data type: u_int8	Change during operation: True

Table 377: Option:

[0]	Off	Continue regulation of an error even when the output frequency cannot be increased or decreased.
[1]	On	Cease regulation of an error when the output frequency can no longer be adjusted.

20-93 PI Proportional Gain

Default value: 0.50	Parameter type: Range	2-setup: All setups
Conversion index: -2	Data type: u_int16	Change during operation: True

Enter the process controller proportional gain. Quick control is obtained at high amplification. However, if amplification is too high, the process may become unstable.

Table 378: Range:

Min: 0	Max: 10	Default value: 0.50
--------	---------	---------------------

20-94 PI Integral Time

Default value: 20 s	Parameter type: Range	2-setup: All setups
Conversion index: -2	Data type: u_int32	Change during operation: True

Enter the process controller integral time. Obtain quick control through a short integral time, though if the integral time is too short, the process becomes unstable. An excessively long integral time disables the integral action.

Table 379: Range:

Min: 0.10 s	Max: 9999 s	Default value: 20 s
-------------	-------------	---------------------

20-97 PI Feed Forward Factor

Default value: 0%	Parameter type: Range	2-setup: All setups
Conversion index: 0	Data type: u_int16	Change during operation: True

Enter the PI feed forward factor. The FF factor sends a constant fraction of the reference signal to bypass PI control. Therefore, the PI can affect only the remaining fraction of the control signal. The FF factor can increase dynamic performance.

Table 380: Range:

Min: 0%	Max: 400%	Default value: 0%
---------	-----------	-------------------

4.16 Parameter Group 22-** Appl. Functions

Parameter group for application monitoring functions.

4.16.1 22-0* Miscellaneous

Parameter group for extra settings.

22-01 Power Filter Time

Default value: 0.50 s	Parameter type: Range	2-setup: All setups
Conversion index: -2	Data type: u_int16	Change during operation: True

Set the time constant for the filtered power readout. A higher value gives a more steady readout but a slower system response to changes.

Table 381: Range:

Min: 0.02 s	Max: 10 s	Default value: 0.50 s
-------------	-----------	-----------------------

22-02 Sleepmode CL Control Mode

Default value: [0] Normal	Parameter type: Option	2-setup: All setups
Conversion index: -	Data type: u_int8	Change during operation: True

This parameter is for sleep mode running in process closed-loop mode. Use this parameter to configure whether to detect the feedback for sleep mode.

Table 382: Option:

[0]	Normal	The feedback is detected. Some parameters are checked.
[1]	Simplified	The feedback is not detected. Only sleep speed and time are checked.

22-04 Check Valve Monitor

Default value: [0] Disabled	Parameter type: Option	2-setup: All setups
Conversion index: -	Data type: u_int8	Change during operation: True

When this function is enabled, the drive monitors the status of check valves in the system, once a damaged check valve is detected, the drive trips *warning 159, Check Valve Failure*.

Table 383: Option:

[0]	Disabled	Disable the function.
[1]	Enabled	Enable the function.

4.16.2 22-2* No-Flow Detection

Parameters for setting up no-flow and dry pump detection.

The drive includes functions for detecting if the load conditions in the system allow the motor to be stopped:

- Low power detection

One of these 2 signals must be active for a set time (*parameter 22-24 No-Flow Delay*) before selected action takes place. Possible actions to select (*parameter 22-23 No-Flow Function*):

- No action
- Warning
- Alarm
- Sleep mode

No-flow Detection

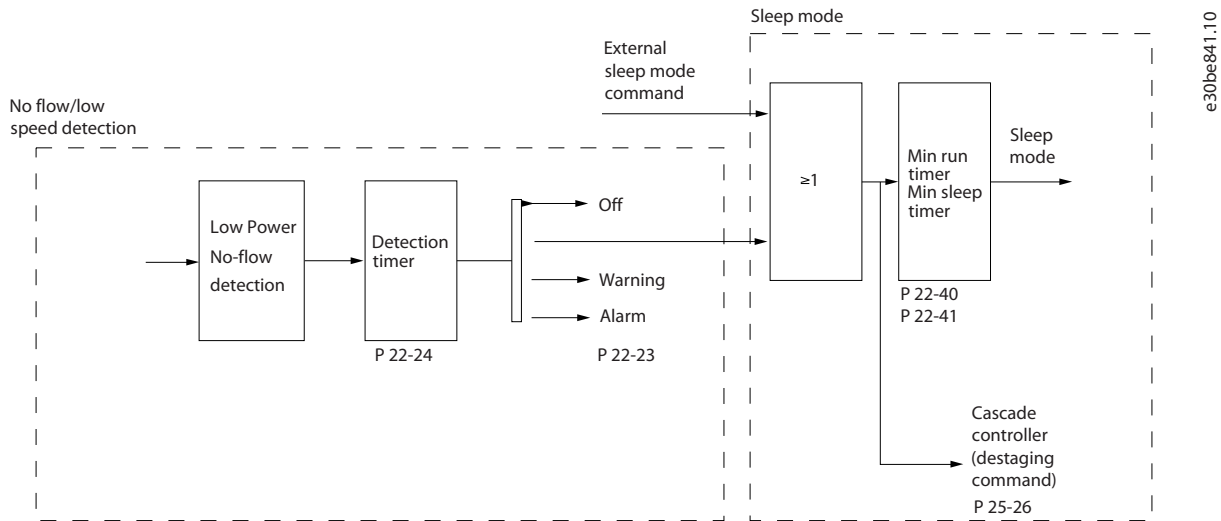

Illustration 18: No-flow Detection

This function is used for detecting a no-flow situation in pump systems where all valves can be closed. Can be used both when controlled by the integrated PI controller in the drive or an external PI controller. Program the actual configuration in *parameter 1-00 Configuration Mode*.

Configuration mode for

- Integrated PI controller: Closed loop.
- External PI controller: Open loop.

NOTICE

Carry out no-flow tuning before setting the PI controller parameters.

Table 384: No-flow Detection

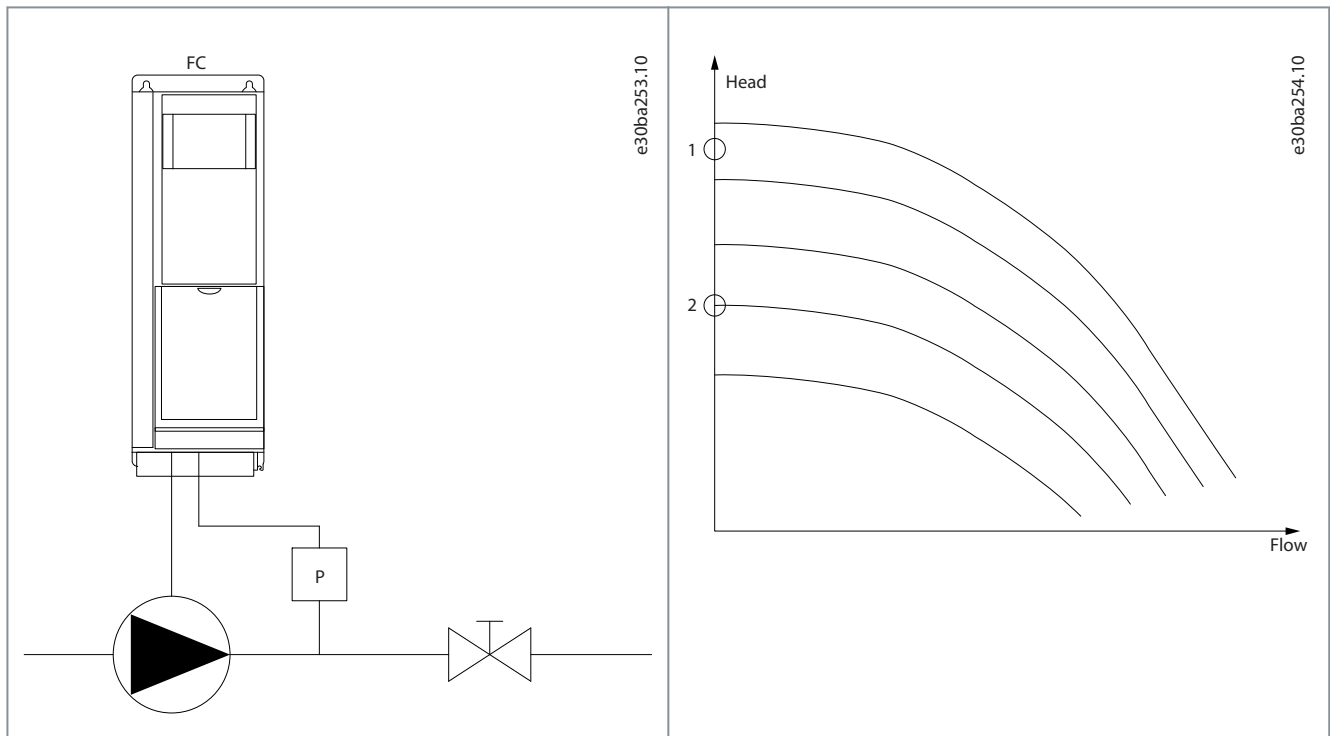

No-flow detection is based on the measurement of speed and power. For a certain speed, the drive calculates the power at no-flow.

This coherence is based on the adjustment of 2 sets of speed and associated power at no-flow. Monitoring power enables detection of no-flow conditions in systems with fluctuating suction pressure, or of the pump having a flat characteristic towards low speed. The 2 sets of data must be based on measurement of power at approximately 50% and 85% of maximum speed with the valves closed. The data is programmed in *parameter group 22-3* No-Flow Power Tuning*.

Enable and commission no-flow detection in *parameter 22-23 No-Flow Function* and *parameter group 22-3* No-Flow Power Tuning*.

22-23 No-Flow Function

Default value: [0] Off	Parameter type: Option	2-setup: All setups
Conversion index: -	Data type: u_int8	Change during operation: True

Select desired action if no flow or minimum speed detected.

Table 385: Option:

[0]	Off
[1]	Sleep mode
[2]	Warning
[3]	Alarm

22-24 No-Flow Delay

Default value: 10 s	Parameter type: Range	2-setup: All setups
Conversion index: 0	Data type: u_int16	Change during operation: True

Set delay before action set in *parameter 22-23 No-Flow Function* takes place if a no-flow condition is detected.

Table 386: Range:

Min: 1 s	Max: 600 s	Default value: 10 s
----------	------------	---------------------

Dry-pump detection

If the pump has run dry (low power consumption-high speed), no-flow detection can also be used for detecting with both the integrated PI controller and an external PI controller.

The 2 conditions for dry-pump signal are as follows:

- Power consumption below no-flow level.
- Pump running at maximum speed or maximum reference open loop, whichever is lowest.

The signal must be active for a set time (*parameter 22-27 Dry Pump Delay*) before the selected action takes place. Possible actions can be selected from *parameter 22-26 Dry Pump Function*.

22-26 Dry Pump Function

Default value: [0] Off	Parameter type: Option	2-setup: All setups
Conversion index: -	Data type: u_int8	Change during operation: True

Select desired action for dry pump operation.

NOTICE

- For drives with constant speed bypass, if an automatic bypass function starts the bypass at persistent alarm conditions, disable the automatic bypass function when [2] Alarm or [3] Man. Reset Alarm is selected for the dry pump function.

Table 387: Option:

[0]	Off	This function is not active.
[1]	Warning	The drive continues to run, but activates a warning (<i>warning 93, dry pump</i>). A drive digital output or a serial communication bus can communicate the warning to other equipment.
[2]	Alarm	<p>The drive stops running and activates an alarm (<i>alarm 93, dry pump</i>). A drive digital output or a serial communication bus can communicate the alarm to other equipment.</p> <div style="background-color: #cccccc; text-align: center; padding: 5px;">NOTICE</div> <ul style="list-style-type: none"> - When this option is selected, do not set <i>parameter 14-20 Reset Mode</i> to [13] <i>Infinite auto reset</i>. Doing so causes the drive to continuously cycle between running and stopping when a dry pump condition is detected.
[3]	Man. Re-set Alarm	The drive stops running and activates an alarm (<i>alarm 93, dry pump</i>). A drive digital output or a serial communication bus can communicate the alarm to other equipment. If this option is selected and the dry pump condition is detected, the drive can only be reset manually.

22-27 Dry Pump Delay

Default value: 10 s	Parameter type: Range	2-setup: All setups
Conversion index: 0	Data type: u_int16	Change during operation: True

Set delay before action set in *parameter 22-26 Dry Pump Function* takes place if a dry-pump condition is detected.

Table 388: Range:

Min: 0 s	Max: 600 s	Default value: 10 s
----------	------------	---------------------

4.16.3 22-3* No-flow Power Tuning

Parameters for setting up low power detection for the no flow function.

22-30 No-Flow Power

Default value: 0 kW	Parameter type: Range	2-setup: All setups
Conversion index: -2	Data type: u_int32	Change during operation: True

Readout of calculated no-flow power at actual speed.

Table 389: Range:

Min: 0 kW	Max: 1000 kW	Default value: 0 kW
-----------	--------------	---------------------

22-31 Power Correction Factor

Default value: 100 %	Parameter type: Range	2-setup: All setups
Conversion index: 0	Data type: u_int16	Change during operation: True

Set a correction if no-flow detection reacts on a too low or too high power value.

Table 390: Range:

Min: 1 %	Max: 400 %	Default value: 100 %
----------	------------	----------------------

22-33 Low Speed [Hz]

Default value: 0 Hz	Parameter type: Range	2-setup: All setups
Conversion index: -1	Data type: u_int16	Change during operation: True

Set output speed used for registration of no-flow power at low speed.

Table 391: Range:

Min: 0 Hz	Max: 400 Hz	Default value: 0 Hz
-----------	-------------	---------------------

22-34 Low Speed Power [kW]

Default value: 0 kW	Parameter type: Range	2-setup: All setups
Conversion index: -2	Data type: u_int32	Change during operation: True

Set no-flow power at low speed.

Table 392: Range:

Min: 0 kW	Max: 5.50 kW	Default value: 0 kW
-----------	--------------	---------------------

22-37 High Speed [Hz]

Default value: 0 Hz	Parameter type: Range	2-setup: All setups
Conversion index: -1	Data type: u_int16	Change during operation: True

Set output speed used for registration of no-flow power at high speed.

Table 393: Range:

Min: 0 Hz	Max: 400 Hz	Default value: 0 Hz
-----------	-------------	---------------------

22-38 High Speed Power [kW]

Default value: 0 kW	Parameter type: Range	2-setup: All setups
Conversion index: -2	Data type: u_int32	Change during operation: True

Set no-flow power at high speed.

Table 394: Range:

Min: 0 kW	Max: 5.50 kW	Default value: 0 kW
-----------	--------------	---------------------

4.16.3.1 No-flow Power Tuning Sequence

NOTICE

Set *parameter 1-03 Torque Characteristics* before tuning takes place.

Procedure

1. To stop flow, close the main valve.
2. Run with motor until the system has reached normal operating temperature.
3. Press the [Hand On] key on the LCP and adjust speed for approximately 85% of the rated speed. Note the exact speed.
4. Read power consumption either by looking for actual power in the data line in the LCP or call *parameter 16-10 Power [kW]* in the Main Menu. Note the power readout.
5. Change speed to approximately 50% of the rated speed. Note the exact speed.
6. Read power consumption either by looking for actual power in the data line in the LCP or call *parameter 16-10 Power [kW]* in the Main Menu. Note the power readout.
7. Program the speeds used in *parameter 22-33 Low Speed [Hz]* and *parameter 22-37 High Speed [Hz]*.
8. Program the associated power values in *parameter 22-34 Low Speed Power [kW]* and *parameter 22-38 High Speed Power [kW]*.
9. Switch back pressing [Auto On] or [Off].

4.16.4 22-4* Sleep Mode

Sleep mode allows the drive to stop itself in situations where the system is in balance. This function saves energy and prevents excessive pressure, water excessively cooled in cooling towers, and building pressurization problems in the system. This is also important as some applications prevent the drive from adjusting the motor down to low speed. This might damage pumps, cause insufficient lubrication in gearboxes, and make fans unstable.

The sleep controller has 2 important functions:

- The ability to go to sleep at the right time.
- The ability to abandon sleep mode at the right time.

The goal is to keep the drive in sleep mode as long as possible to avoid cycling the motor on and off frequently, and also keep the controlled system variable within the acceptable range.

N O T I C E

Sleep mode is not active when local reference is active (set speed manually using the navigation keys on the LCP). Sleep mode does not work in local mode. Perform an auto setup in open loop before setting input/output in closed loop.

22-40 Minimum Run Time

Default value: 10 s	Parameter type: Range	2-setup: All setups
Conversion index: 0	Data type: u_int16	Change during operation: True

Set the wanted minimum running time for the motor after a start command (digital input or bus) before entering sleep mode.

Table 395: Range:

Min: 0 s	Max: 600 s	Default value: 10 s
----------	------------	---------------------

22-41 Minimum Sleep Time

Default value: 10 s	Parameter type: Range	2-setup: All setups
Conversion index: 0	Data type: u_int16	Change during operation: True

Set the minimum time for staying in sleep mode. This time overrides any wake-up conditions.

Table 396: Range:

Min: 0 s	Max: 600 s	Default value: 10 s
----------	------------	---------------------

22-43 Wake-Up Speed [Hz]

Default value: 10	Parameter type: Range	2-setup: All setups
Conversion index: -1	Data type: u_int16	Change during operation: True

Only to be used if *parameter 1-00 Configuration Mode* is set to [0] *Open loop*, and an external controller applies speed reference. Set the reference speed at which the sleep mode should be deactivated. The wake-up speed must not exceed the setting in *parameter 4-14 Motor Speed High Limit [Hz]*.

Table 397: Range:

Min: 0	Max: 400.0	Default value: 0
--------	------------	------------------

22-44 Wake-Up Ref./FB Diff

Default value: 10%	Parameter type: Range	2-setup: All setups
Conversion index: 0	Data type: u_int8	Change during operation: True

Only to be used if *parameter 1-00 Configuration Mode* is set for [3] *Closed loop* and the integrated PI controller is used for controlling the pressure. Set the pressure drop allowed in percentage of setpoint for the pressure (P_{set}) before canceling the sleep mode.

Table 398: Range:

Min: 0%	Max: 100%	Default value: 10%
---------	-----------	--------------------

22-45 Setpoint Boost

Default value: 0%	Parameter type: Range	2-setup: All setups
Conversion index: 0	Data type: int8	Change during operation: True

Only to be used if *parameter 1-00 Configuration Mode* is set for [3] *Closed loop* and the integrated PI controller is used. In systems with for example, constant pressure control, it is advantageous to increase the system pressure before the motor is stopped. This increase extends the time the motor is stopped and helps to avoid frequent start/stop. Set the required overpressure/overtemperature in percentage of setpoint for the pressure (P_{set})/ temperature before entering the sleep mode. If setting for 5%, the boost pressure is $P_{set} \times 1.05$. The negative values can be used for cooling tower control where a negative change is needed.

Table 399: Range:

Min: -100 %	Max: 100 %	Default value: 0%
-------------	------------	-------------------

22-46 Maximum Boost Time

Default value: 60 s	Parameter type: Range	2-setup: All setups
Conversion index: 0	Data type: u_int16	Change during operation: True

Only to be used if *parameter 1-00 Configuration Mode* is set for [3] *Closed loop* and the integrated PI controller is used for controlling the pressure. Set the maximum time for which boost mode is allowed. If the set time is exceeded, the drive enters the sleep mode without waiting for the set boost pressure to be reached.

Table 400: Range:

Min: 0 s	Max: 600 s	Default value: 60 s
----------	------------	---------------------

22-47 Sleep Speed [Hz]

Default value: 0	Parameter type: Range	2-setup: All setups
Conversion index: -1	Data type: u_int16	Change during operation: True

Set the speed below which the drive goes into sleep mode.

Table 401: Range:

Min: 0	Max: 400.0	Default value: 0
--------	------------	------------------

22-48 Sleep Delay Time

Default value: 0 s	Parameter type: Range	2-setup: All setups
Conversion index: 0	Data type: u_int16	Change during operation: True

Set the delay time that the motor waits before entering sleep mode when the condition to enter sleep mode is met.

Table 402: Range:

Min: 0 s	Max: 3600 s	Default value: 0 s
----------	-------------	--------------------

22-49 Wake-Up Delay Time

Default value: 0 s	Parameter type: Range	2-setup: All setups
Conversion index: 0	Data type: u_int16	Change during operation: True

Set the delay time that the motor waits before waking up from sleep mode when the condition for wake-up is met.

Table 403: Range:

Min: 0 s	Max: 3600 s	Default value: 0 s
----------	-------------	--------------------

4.16.4.1 Running Sleep Mode in Open Loop

Procedure

1. The motor speed is less than the speed set in *parameter 22-47 Sleep Speed [Hz]*. The motor runs longer than the time duration set in *parameter 22-40 Minimum Run Time*. The sleep condition lasts longer than the time set in *parameter 22-48 Sleep Delay Time*.
2. The drive ramps the motor speed down to *parameter 1-82 Min Speed for Function at Stop [Hz]*.
3. The drive activates *parameter 1-80 Function at Stop*. The drive is now in sleep mode.
4. The drive compares the speed setpoint with *parameter 22-43 Wake-Up Speed [Hz]* to detect a wake-up situation.
5. The speed setpoint is greater than *parameter 22-43 Wake-Up Speed [Hz]*. The sleep condition has lasted longer than the time set in *parameter 22-41 Minimum Sleep Time*. The wakeup condition lasts longer than the time set in *parameter 22-49 Wake-Up Delay Time*. The drive is now out of sleep mode.
6. Go back to speed open-loop control (ramp motor speed up to the speed setpoint).

4.16.4.2 Running Sleep Mode in Closed Loop

Procedure

1. The drive goes into boost status if the following conditions are met.
 - a. If *parameter 22-02 Sleepmode CL Control Mode* is set to [0] Normal:



The motor speed is less than the value in *parameter 22-47 Sleep Speed [Hz]*.
 The feedback is above the reference.
 The motor runs longer than the time in *parameter 22-40 Minimum Run Time*.
 The sleep condition lasts longer than the time in *parameter 22-48 Sleep Delay Time*.

- b. If *parameter 22-02 Sleepmode CL Control Mode* is set to [1] Simplified:



The motor speed is less than the value in *parameter 22-47 Sleep Speed [Hz]*.
 The motor runs longer than the time in *parameter 22-40 Minimum Run Time*.
 The sleep condition lasts longer than the time in *parameter 22-48 Sleep Delay Time*.

- c. If *parameter 22-45 Setpoint Boost* is not set, the drive goes into sleep mode.
2. After the time in *parameter 22-46 Maximum Boost Time* has passed, the drive ramps down the motor speed to the speed in *parameter 1-82 Min Speed for Function at Stop [Hz]*.
 3. The drive activates *parameter 1-80 Function at Stop*. The drive is now in sleep mode.
 4. The drive is out of sleep mode when the error between the reference and the feedback is greater than *parameter 22-44 Wake-Up Ref./FB Diff*, and the sleep time is longer than the time in *parameter 22-41 Minimum Sleep Time*, and the wake-up condition lasts longer than the time set in *parameter 22-48 Sleep Delay Time*.
 5. The drive goes back to closed-loop control.

4.16.5 22-5* End of Curve

End of Curve

The end-of-curve condition occurs when a pump is yielding a large volume to ensure the set pressure. This situation can occur if there is a leakage in the distribution pipe system after the pump which causes the pump to operate at the end of the pump characteristic. If the feedback is below the setpoint for the required pressure for a set time (*parameter 22-51 End of Curve Delay*), and the pump runs with maximum speed set in *parameter 4-14 Motor Speed High Limit [Hz]*, the function selected in *parameter 22-50 End of Curve Function* takes place.

It is possible to get a signal on 1 of the digital outputs by selecting [192] *End of curve* in *parameter group 5-3* Digital Outputs* and/or *parameter group 5-4* Relays*. The signal is present when end-of-curve condition occurs and the selection in *parameter 22-50 End of Curve Function* is different from [0] Off.

The end-of-curve function can only be used when operating with the built-in PID controller ([3] *Process Closed Loop* in parameter 1-00 *Configuration Mode*).

22-50 End of Curve Function

Default value: [0] Off	Parameter type: Option	2-setup: All setups
Conversion index: -	Data type: u_int8	Change during operation: True

Select desired action if an end-of-curve operation is detected.

NOTICE

For drives with constant speed bypass, if an automatic bypass function starts the bypass at persistent alarm conditions, disable the automatic bypass function when [2] *Alarm* or [3] *Man. Reset Alarm* is selected for the end-of-curve function.

Table 404: Option:

[0]	Off	This function is not active.	
[1]	Warning	The drive continues to run, but activates a warning (<i>warning 94, end of curve</i>). A drive digital output or a serial communication bus can communicate the warning to other equipment.	
[2]	Alarm	The drive stops running and activates an alarm (<i>alarm 94, end of curve</i>). A drive digital output or a serial communication bus can communicate the alarm to other equipment.	
<table border="1" style="background-color: #cccccc; margin: 0 auto;"> <tr> <td>NOTICE</td> </tr> </table> <ul style="list-style-type: none"> - When this option is selected, do not set <i>parameter 14-20 Reset Mode</i> to [13] <i>Infinite auto reset</i>. Doing so causes the drive to continuously cycle between running and stopping when a dry pump condition is detected. 			NOTICE
NOTICE			
[3]	Man. Re-set Alarm	The drive stops running and activates an alarm (<i>warning 94, end of curve</i>). A drive digital output or a serial communication bus can communicate the alarm to other equipment. If this option is selected and the end-of-curve condition is detected, the drive can only be reset manually.	

22-51 End of Curve Delay

Default value: 10 s	Parameter type: Range	2-setup: All setups
Conversion index: 0	Data type: u_int16	Change during operation: True

When an end-of-curve condition is detected, a timer is activated. When the time set in this parameter expires, and the end-of-curve condition is steady during the entire period, the function set in *parameter 22-50 End of Curve Function* is activated. If the condition disappears before the timer expires, the timer is reset.

Table 405: Range:

Min: 0 s	Max: 600 s	Default value: 10 s
----------	------------	---------------------

4.16.6 22-6* Broken Belt Detection

Parameters for setting up broken-belt detection. The function monitors the motor torque.

Use broken-belt detection in both closed-loop systems and open-loop systems for pumps and fans. If the estimated motor torque (current) is below the broken-belt torque (current) value (*parameter 22-61 Broken Belt Torque*), and the drive output frequency is above or equal to 15 Hz, *parameter 22-60 Broken Belt Function* is performed.

22-60 Broken Belt Function

Default value: [0] Off	Parameter type: Option	2-setup: All setups
Conversion index: -	Data type: u_int8	Change during operation: True

Select the action to be performed if the broken-belt condition is detected.

N O T I C E

Do not set *parameter 14-20 Reset Mode* to [13] *Infinite auto reset*, when *parameter 22-60 Broken Belt Function* is set to [2] *Trip*. Doing so causes the drive to continuously cycle between running and stopping when a broken-belt condition is detected.

N O T I C E

If the automatic bypass function is enabled, the bypass starts when the drive experiences a persistent alarm condition. In this case, disable the automatic bypass function if [2] *Trip* is selected as the broken-belt function.

Table 406: Option:

[0]	Off	This function is not active.
[1]	Warning	The drive continues to run, but activates a broken-belt warning (<i>warning 95, Broken Belt</i>). A drive digital output or a serial communication bus can communicate the warning to other equipment.
[2]	Trip	The drive stops running and activates a broken-belt alarm (<i>alarm 95, Broken Belt</i>). A drive digital output or a serial communication bus can communicate the alarm to other equipment.

22-61 Broken Belt Torque

Default value: 10%	Parameter type: Range	2-setup: All setups
Conversion index: 0	Data type: u_int8	Change during operation: True

Set the broken-belt torque as a percentage of the rated motor torque.

Table 407: Range:

Min: 5%	Max: 100%	Default value: 10%
---------	-----------	--------------------

22-62 Broken Belt Delay

Default value: 10 s	Parameter type: Range	2-setup: All setups
Conversion index: 0	Data type: u_int16	Change during operation: True

Set the time for which the broken-belt conditions must be active before carrying out the action selected in *parameter 22-60 Broken Belt Function*.

Table 408: Range:

Min: 0 s	Max: 600 s	Default value: 10 s
----------	------------	---------------------

4.16.7 22-8* Flow Compensation

In certain applications, it is not possible for a pressure transducer to be placed at a remote point in the system, and it can only be placed close to the fan/pump outlet. Flow compensation operates by adjusting the setpoint according to the output frequency, which is almost proportional to flow. Thus, it compensates for higher losses at higher flow rates.

H_{DESIGN} (required pressure) is the setpoint for closed-loop (PI) operation of the drive and is set as for closed-loop operation without flow compensation.

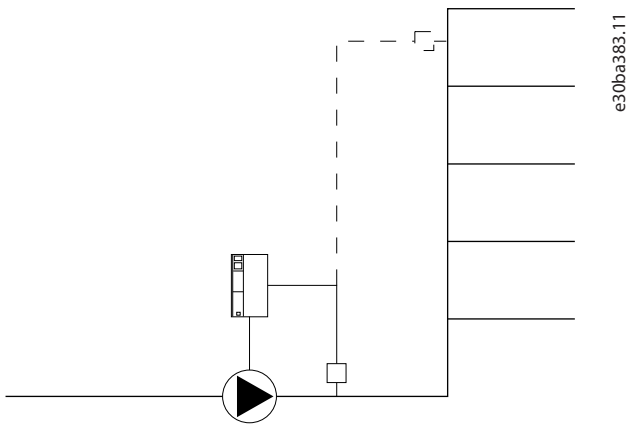

Illustration 19: Flow Compensation Set-up

There are 2 methods which can be employed, depending on whether the speed at system design working point is known.

Table 409: Speed at Design Point Known/Unknown

Parameter used	Speed at design point KNOWN	Speed at design point UNKNOWN
Parameter 22-80 Flow Compensation	+	+
Parameter 22-81 Square-linear Curve Approximation	+	+
Parameter 22-82 Work Point Calculation	+	+
Parameter 22-84 Speed at No-Flow [Hz]	+	+
Parameter 22-86 Speed at Design Point [Hz]	+	-
Parameter 22-87 Pressure at No-Flow Speed	+	+
Parameter 22-88 Pressure at Rated Speed	-	+
Parameter 22-89 Flow at Design Point	-	+
Parameter 22-90 Flow at Rated Speed	-	+

22-80 Flow Compensation

Default value: [0] Disabled	Parameter type: Option	2-setup: All setups
Conversion index: -	Data type: u_int8	Change during operation: True

Table 410: Option:

[0]	Disabled	Disable flow compensation of setpoint.
[1]	Enabled	Enable flow compensation of setpoint.

22-81 Square-linear Curve Approximation

Default value: 100%	Parameter type: Range	2-setup: All setups
Conversion index: 0	Data type: u_int8	Change during operation: True

Adjust shape of control curve. 0% = straight line, 100% = maximum parabola.

Table 411: Range:

Min: 0%	Max: 100%	Default value: 100%
---------	-----------	---------------------

22-82 Work Point Calculation

Default value: [0] Disabled	Parameter type: Option	2-setup: All setups
Conversion index: -	Data type: u_int8	Change during operation: True

Table 412: Option:

[0]	Disabled	Disable calculation of working point at rated speed.
[1]	Enabled	Enable calculation of working point at rated speed.

22-84 Speed at No-Flow [Hz]

Default value: Configuration dependent	Parameter type: Range	2-setup: All setups
Conversion index: -1	Data type: u_int16	Change during operation: True

Set the motor speed in Hz at which flow is 0 and minimum pressure is achieved.

Table 413: Range:

Min: 0 Hz	Max: 400.0 Hz	Default value: Configuration dependent
-----------	---------------	--

22-86 Speed at Design Point [Hz]

Default value: Configuration dependent	Parameter type: Range	2-setup: All setups
Conversion index: -1	Data type: u_int16	Change during operation: True

Set the motor speed in Hz at which system design working point is achieved.

Table 414: Range:

Min: 0 Hz	Max: 400.0 Hz	Default value: Configuration dependent
-----------	---------------	--

22-87 Pressure at No-Flow Speed

Default value: 0	Parameter type: Range	2-setup: All setups
Conversion index: -3	Data type: u_int32	Change during operation: True

Set the pressure value corresponding to speed at no flow.

Table 415: Range:

Min: 0	Max: 4999.000	Default value: 0
--------	---------------	------------------

22-88 Pressure at Rated Speed

Default value: 4999.000	Parameter type: Range	2-setup: All setups
Conversion index: -3	Data type: u_int32	Change during operation: True

Set the pressure value corresponding to pressure at rated speed.

Table 416: Range:

Min: 0	Max: 4999.000	Default value: 4999.000
--------	---------------	-------------------------

22-89 Flow at Design Point

Default value: 0	Parameter type: Range	2-setup: All setups
Conversion index: -3	Data type: int32	Change during operation: True

Set the flow value corresponding to flow at design point.

Table 417: Range:

Min: 0	Max: 4999.000	Default value: 0
--------	---------------	------------------

22-90 Flow at Rated Speed

Default value: 0	Parameter type: Range	2-setup: All setups
Conversion index: -3	Data type: int32	Change during operation: True

Set the flow value corresponding to flow at rated speed.

Table 418: Range:

Min: 0	Max: 4999.000	Default value: 0
--------	---------------	------------------

4.17 Parameter Group 23-** Time-based Functions

Parameter group for functions related to the simple timer clock.

4.17.1 23-0* Timed Interval Running Settings

Settings for running the motor for a specific time, at a specific speed, and in a specific direction within a specific interval.

23-05 Interval between operation

Default value: 0 min	Parameter type: Range	2-setup: All setups
Conversion index: 0	Data type: u_int16	Change during operation: True

Interval between start of the motor in minutes. When this parameter is set to 0, the timer function is disabled.

Table 419: Range:

Min: 0 min	Max: 65535 min	Default value: 0 min
------------	----------------	----------------------

23-06 Running time

Default value: 60 s	Parameter type: Range	2-setup: All setups
Conversion index: 0	Data type: u_int16	Change during operation: True

Running time of the motor after start in seconds.

Table 420: Range:

Min: 0 s	Max: 65535 s	Default value: 60 s
----------	--------------	---------------------

23-07 Running speed and direction

Default value: 50 Hz	Parameter type: Range	2-setup: All setups
Conversion index: -1	Data type: u_int16	Change during operation: True

Running speed and direction in Hz. Positive value means *Forward*, and negative value means *Reverse*.

Table 421: Range:

Min: -400.0 Hz	Max: 400.0 Hz	Default value: 50 Hz
----------------	---------------	----------------------

4.18 Parameter Group 24-** Appl. Functions 2

4.18.1 24-0* Fire Mode

! C A U T I O N !

EQUIPMENT DAMAGE AND PERSONAL INJURY

Non-interruption of the drive due to fire mode operation could cause overpressure and damage the system and its components, including dampers, and air ducts. The drive itself could be damaged and it may cause damage or fire.

- Ensure that the system is properly designed and components used are carefully selected.
- Ensure that the ventilation systems working in life safety applications are approved by the local fire authorities.

Background

Fire mode is for use in critical situations, where it is imperative for the motor to keep running, regardless of the drive's normal protective functions. These situations could be ventilation fans in tunnels or stairwells for instance, where continued operation of the fan facilitates safe evacuation of personnel in case of a fire. Some selections of fire mode function cause alarms and trip conditions to be ignored, enabling the motor to run without interruption.

Activation

Fire mode is activated only via digital input terminals. See *parameter group 5-1* Digital Inputs*.

Messages in display

When fire mode is activated, the display shows the status message *Fire Mode*. Once the fire mode is deactivated, the status message disappears.

If an alarm with warranty implications (see *parameter 24-09 FM Alarm Handling*) occurs while the drive is active in fire mode, the display shows the status message *Fire Mode Limits Exceeded*. Once this status message appears in the display, it remains until a power cycle is performed. The drive automatically logs and stores the condition in the memory and the warranty is still lost in case the drive is returned for service. Digital and relay outputs can be configured for the status messages *Fire Mode Active*. See *parameter group 5-3* Digital Outputs* and *parameter group 5-4* Relays*. Access the status messages *Fire Mode* and *Fire Mode Limits Exceeded* via the extended status word.

Table 422: Fire Mode Display Messages

Message	Type	LCP	Message	Warning word 2	Extended status word 2
Fire Mode	Status	+	+		+(bit 25)
Fire Mode Limits Exceeded	Status	+	+		+(bit 27)

Log

The fire mode log shows an overview of events related to fire mode in the fire mode log, see also *parameter group 18-1* Fire Mode Log*. The log includes up to 10 of the latest events. Fire Mode Limits Exceeded has a higher priority than Fire Mode Active. The log cannot be reset.

The following events are logged:

- Fire mode activated.
- Fire mode limits exceeded (warranty-affecting alarms).

All other alarms occurring while fire mode is active are logged as usual.

N O T I C E

During fire mode operation, all stop commands to the drive are ignored, including coast, coast inverse, and external interlock.

N O T I C E

If setting the command [11] *Start Reversing* on a digital input terminal in *parameter 5-10 Terminal 18 Digital Input*, the drive understands this command as a reversing command.

24-00 FM Function

Default value: [0] Disabled	Parameter type: Option	2-setup: 1 setup
Conversion index: -	Data type: u_int8	Change during operation: True

Select the function to be preformed when entering fire mode.

NOTICE
In fire mode, alarms are produced or ignored in accordance with the selection in <i>parameter 24-09 FM Alarm Handling</i> .

Table 423: Option:

[0]	Disabled	Fire mode function is not active.
[1]	Forward with Single-Ref	In this mode, the motor continues to operate in a clockwise direction. The reference is from <i>parameter 24-05 FM Preset Reference</i> .
[2]	Reverse with Single-Ref	In this mode, the motor continues to operate in a counterclockwise direction. The reference is from <i>parameter 24-05 FM Preset Reference</i> .
[3]	Coast	While this mode is selected, the output is disabled, and the motor is allowed to coast to stop. When <i>parameter 24-01 Fire Mode Configuration</i> is set to [3] <i>Closed Loop</i> , this mode cannot be selected.
[4]	Fwd/Rev with Single-Ref	In this mode, the motor operates in a clockwise direction. When receiving a reversing signal, the motor operates in counterclockwise direction. If <i>parameter 24-01 Fire Mode Configuration</i> is set to [3] <i>Closed Loop</i> , the motor cannot operate in counterclockwise direction. The reference is from <i>parameter 24-05 FM Preset Reference</i> .
[5]	Forward with Multi-Ref	In this mode, the motor continues to operate in a clockwise direction. The reference is from <i>parameter 24-08 Mul FM Preset Reference</i> .
[6]	Reverse with Multi-Ref	In this mode, the motor continues to operate in a counterclockwise direction. The reference is from <i>parameter 24-08 Mul FM Preset Reference</i> .
[7]	Fwd/Rev with Multi-Ref	In this mode, the motor operates in a clockwise direction. When receiving a reversing signal, the motor operates in counterclockwise direction. If <i>parameter 24-01 Fire Mode Configuration</i> is set to [3] <i>Closed Loop</i> , the motor cannot operate in counterclockwise direction. The reference is from <i>parameter 24-08 Mul FM Preset Reference</i> .

24-01 Fire Mode Configuration

Default value: [0] Open Loop	Parameter type: Option	2-setup: All setups
Conversion index: -	Data type: u_int8	Change during operation: True

Select to use closed-loop or open-loop operations.

Table 424: Option:

[0]	Open Loop	Select open-loop operation.		
[3]	Process Closed Loop	<table border="1" style="background-color: #cccccc; text-align: center;"> <tr> <td>NOTICE</td> </tr> <tr> <td>When set to [3] <i>Process Closed Loop</i>, the commands <i>Reversing</i> and <i>Start Reversing</i> do not reverse the direction of the motor.</td> </tr> </table> <p>Motor speed is determined by a reference from the built-in PI controller varying the motor speed as of a closed-loop control process (for example constant pressure or flow). Configure the PI controller in <i>parameter group 20-8* PI Basic Setting</i> and <i>parameter group 20-9* PI Controller</i>.</p>	NOTICE	When set to [3] <i>Process Closed Loop</i> , the commands <i>Reversing</i> and <i>Start Reversing</i> do not reverse the direction of the motor.
NOTICE				
When set to [3] <i>Process Closed Loop</i> , the commands <i>Reversing</i> and <i>Start Reversing</i> do not reverse the direction of the motor.				

24-03 Fire Mode Min Reference

Default value: 0 FireModeUnit	Parameter type: Range	2-setup: All setups
Conversion index: -3	Data type: int32	Change during operation: True

The minimum reference is the lowest value obtainable by summing the references. The minimum reference value and unit matches the choice of configuration in *parameter 1-00 Configuration Mode* and the unit in *parameter 20-12 Reference/Feedback Unit*.

Table 425: Range:

Min: -4999.0	Max: 4999.0 FireModeUnit	Default value: 0 FireModeUnit
--------------	--------------------------	-------------------------------

24-04 Fire Mode Max Reference

Default value: 50.000 FireModeUnit	Parameter type: Range	2-setup: All setups
Conversion index: -3	Data type: int32	Change during operation: True

The maximum reference is the highest value obtainable by summing all references. The maximum reference value and unit matches the choice of configuration in *parameter 1-00 Configuration Mode* and the unit in *parameter 20-12 Reference/Feedback Unit*.

Table 426: Range:

Min: -4999.0	Max: 4999.0 FireModeUnit	Default value: 50.000 FireModeUnit
--------------	--------------------------	------------------------------------

24-05 FM Preset Reference

Default value: 0%	Parameter type: Range	2-setup: All setups
Conversion index: 0	Data type: int16	Change during operation: True

Enter the required preset reference/setpoint as a percentage of the fire mode maximum reference set in Hz.

Table 427: Range:

Min: -100%	Max: 100%	Default value: 0%
------------	-----------	-------------------

24-06 Fire Mode Reference Source

Default value: [0] No function	Parameter type: Option	2-setup: All setups
Conversion index: -	Data type: u_int8	Change during operation: True

Table 428: Option:

[0]	No function
[1]	Analog input 53
[2]	Analog input 54
[7]	Pulse input 29

24-07 Fire Mode Feedback Source

Default value: [0] No function	Parameter type: Option	2-setup: All setups
Conversion index: -	Data type: u_int8	Change during operation: True

This parameter defines which input on the drive should be treated as the source of the feedback signal.

Table 429: Option:

[0]	No function
[1]	Analog input 53

[2]	Analog input 54
[3]	Pulse input 29
[100]	Bus feedback 1
[101]	Bus feedback 2

24-08 Mul FM Preset Reference

Default value: 0%	Parameter type: Range	2-setup: All setups
Conversion index: -2	Data type: int16	Change during operation: True

Enter the required multi preset reference/setpoint for firemode operation. For selecting dedicated references, select fire mode reference bit 0/1/2 [190], [191], or [192] for the corresponding digital inputs in *parameter group 5-1* Digital Inputs*.

Table 430: Range:

Min: -100%	Max: 100%	Default value: 0%
------------	-----------	-------------------

24-09 Fire Mode Alarm Handling

Default value: [1] Trip, crit. alarms	Parameter type: Option	2-setup: 1 setup
Conversion index: -	Data type: u_int8	Change during operation: False

NOTICE

Certain alarms can affect the lifetime of the drive. If 1 of these ignored alarms occurs while in fire mode, a log of the event is stored in the fire mode log.

In fire mode log, the 10 latest events of alarms that affect warranty, fire mode activation, and fire mode deactivation are stored.

NOTICE

The setting in *parameter 14-20 Reset Mode* is disregarded if fire mode is active (see *parameter group 24-0* Fire Mode*).

Table 431: Fire Mode Alarm Handling

Number	Description	Critical alarms	Warranty affecting alarms
4	Mains ph. loss	–	x
7	DC over volt	x	x
9	Inverter overloaded	–	x
13	Overcurrent	x	x
14	Ground fault	x	x
16	Short circuit	x	x
38	Internal fault	x	–
69	Power card temp	–	x

Table 432: Option:

[0]	Trip+reset, critical alarms	If this mode is selected, the drive continues to run, ignoring most alarms, even if doing so may damage the drive. Critical alarms are alarms that cannot be suppressed but a restart attempt is possible (infinity automatic reset).
[1]	Trip, crit. alarms	In case of a critical alarm, the drive trips and does not auto-restart (manual reset).
[2]	Trip, all alarms/ test	It is possible to test the operation of fire mode, but all alarm states are activated normally (manual reset).

4.18.2 24-1* Drive Bypass

If a fire mode coast occurs (see *parameter 24-00 FM Function*), the drive includes a feature that can automatically activate an external electro-mechanical bypass.

The bypass switches the motor to operation directly on line. One of the digital outputs or relays in the drive activates the external bypass, when programmed in *parameter group 5-3* Digital Outputs* or *parameter group 5-4* Relays*.

NOTICE

The drive bypass cannot be deactivated if in fire mode. It is deactivated only by either removing the fire mode command signal or the supply to the drive.

When the drive bypass function is activated, the display on the LCP shows the status message *Drive bypass*. This message has a higher priority than the fire mode status messages. When the automatic drive bypass function is enabled, it cuts in the external bypass according to the following illustration.

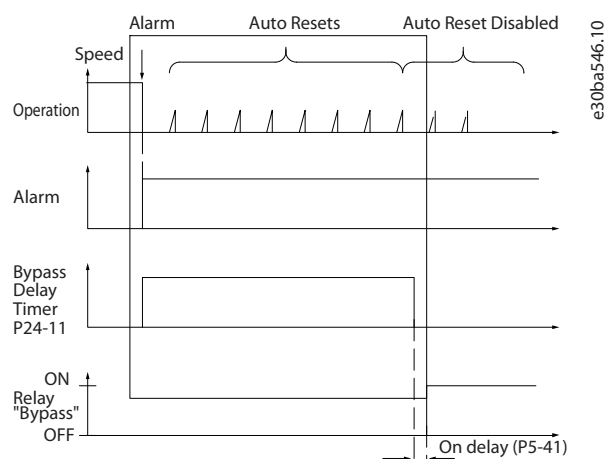

Read the status in the extended status word 2, bit number 24.

24-10 Drive Bypass Function

Default value: [0] Disabled	Parameter type: Option	2-setup: 1 setup
Conversion index: -	Data type: u_int8	Change during operation: True

This function allows to disable or enable drive bypass in fire mode.

Table 433: Option:

[0]	Disabled	Disable the function.
[2]	Enabled (Fire Mode only)	If the timer expires before reset attempts have completed, the bypass function operates a trip at critical alarms, coast, or bypass delay timer.

24-11 Drive Bypass Delay Time

Default value: 0 s	Parameter type: Range	2-setup: 1 setup
Conversion index: 0	Data type: u_int16	Change during operation: True

Programmable in 1 s increments. Once the bypass function is activated in accordance with the setting in *parameter 24-10 Drive Bypass Function*, the bypass delay timer begins to operate. If the drive has been set for several restart attempts, the timer continues to run while the drive tries to restart. If the motor has restarted within the time period of the bypass delay timer, the timer is reset.

If the motor fails to restart at the end of the bypass delay time, the drive bypass relay, which has been programmed for bypass in *parameter 5-40 Function Relay*, is activated.

Where no restart attempts are programmed, the timer runs for the delay period set in this parameter and then activates the drive bypass relay, which has been programmed for bypass in *parameter 5-40 Function Relay*.

Table 434: Range:

Min: 0 s	Max: 600 s	Default value: 0 s
----------	------------	--------------------

4.19 Parameter Group 25-** Cascade Controller

Parameter group for configuring the cascade controller for staging multiple pumps, fans, or compressors.

4.19.1 25-0* System Settings

Parameters related to the control principles and configuration of the system.

25-00 Cascade Controller

Default value: [0] Disabled	Parameter type: Option	2-setup: 1 setup
Conversion index: -	Data type: u_int8	Change during operation: False

Enable or disable the cascade controller which is used for staging multiple pumps.

Table 435: Option:

[0]	Disabled
[1]	Enabled

25-04 Pump Cycling

Default value: [0] Disabled	Parameter type: Option	2-setup: All setups
Conversion index: -	Data type: u_int8	Change during operation: True

Choose the method for determining the order of cutting in/out the fixed-speed pumps.

Table 436: Option:

[0]	Disabled
[1]	Enabled

25-05 Fixed Lead Pump

Default value: [1] Yes	Parameter type: Option	2-setup: 1 setup
Conversion index: -	Data type: u_int8	Change during operation: False

Choose if the lead pump is fixed (Yes) or can be cycled (No).

Table 437: Option:

[0]	No
[1]	Yes

25-06 Number of Pumps

Default value: 2	Parameter type: Range	2-setup: 1 setup
Conversion index: 0	Data type: u_int8	Change during operation: False

Set the total number of pumps including the variable speed pump.

Table 438: Range:

Min: 2	Max: 5	Default value: 2
--------	--------	------------------

4.19.2 25-2* Bandwidth Settings

Parameters for setting limits related to staging and destaging.

25-20 Staging Bandwidth

Default value: 10%	Parameter type: Range	2-setup: All setups
Conversion index: 0	Data type: u_int8	Change during operation: True

Set the SBW percentage to accommodate system pressure fluctuation.

Table 439: Range:

Min: 1%	Max: 100%	Default value: 10%
---------	-----------	--------------------

25-21 Override Bandwidth

Default value: 100%	Parameter type: Range	2-setup: All setups
Conversion index: 0	Data type: u_int8	Change during operation: True

Set the OBW for when to override the staging/destaging timers for immediate response.

Table 440: Range:

Min: 1%	Max: 100%	Default value: 100%
---------	-----------	---------------------

25-22 Fixed Speed Bandwidth

Default value: 10%	Parameter type: Range	2-setup: All setups
Conversion index: 0	Data type: u_int8	Change during operation: True

Set the staging bandwidth to use when only fixed-speed pumps are running.

Table 441: Range:

Min: 1%	Max: 100%	Default value: 10%
---------	-----------	--------------------

25-23 SBW Staging Delay

Default value: 15 s	Parameter type: Range	2-setup: All setups
Conversion index: 0	Data type: u_int16	Change during operation: True

Staging a pump on is delayed by the length of time programmed.

Table 442: Range:

Min: 0 s	Max: 3000 s	Default value: 15 s
----------	-------------	---------------------

25-24 SBW Destaging Delay

Default value: 15 s	Parameter type: Range	2-setup: All setups
Conversion index: 0	Data type: u_int16	Change during operation: True

Destaging a pump is delayed by the length of time programmed.

Table 443: Range:

Min: 0 s	Max: 3000 s	Default value: 15 s
----------	-------------	---------------------

25-25 OBW Time

Default value: 10 s	Parameter type: Range	2-setup: All setups
Conversion index: 0	Data type: u_int16	Change during operation: True

OBW timer prevents staging a pump until the system pressure is stabilized.

Table 444: Range:

Min: 0 s	Max: 300 s	Default value: 10 s
----------	------------	---------------------

25-27 Stage Function

Default value: [1] Enabled	Parameter type: Option	2-setup: All setups
Conversion index: -	Data type: u_int8	Change during operation: True

Table 445: Option:

[0]	Disabled	Disable the stage function timer.
[1]	Enabled	Enable the stage function timer.

25-28 Stage Function Time

Default value: 15 s	Parameter type: Range	2-setup: All setups
Conversion index: 0	Data type: u_int16	Change during operation: True

With the lead pump at maximum speed, a fixed-speed pump is staged on when the programmed time expires.

Table 446: Range:

Min: 0 s	Max: 300 s	Default value: 15 s
----------	------------	---------------------

25-29 Destage Function

Default value: [1] Enabled	Parameter type: Option	2-setup: All setups
Conversion index: -	Data type: u_int8	Change during operation: True

Table 447: Option:

[0]	Disabled	Disable the destage function timer.
[1]	Enabled	Enable the destage function timer.

25-30 Destage Function Time

Default value: 15 s	Parameter type: Range	2-setup: All setups
Conversion index: 0	Data type: u_int16	Change during operation: True

With the lead pump at minimum speed, a fixed speed pump is destaged when the programmed time expires.

Table 448: Range:

Min: 0 s	Max: 300 s	Default value: 15 s
----------	------------	---------------------

4.19.3 25-4* Staging Settings

Parameters for setting conditions for staging and destaging.

25-42 Staging Threshold

Default value: 90%	Parameter type: Range	2-setup: All setups
Conversion index: 0	Data type: u_int8	Change during operation: True

The percentage of maximum pump speed to stage on a fixed-speed pump.

Table 449: Range:

Min: 0%	Max: 100%	Default value: 90%
---------	-----------	--------------------

25-43 Destaging Threshold

Default value: 50%	Parameter type: Range	2-setup: All setups
Conversion index: 0	Data type: u_int8	Change during operation: True

The percentage of maximum pump speed to destage a fixed-speed pump.

Table 450: Range:

Min: 0%	Max: 100%	Default value: 50%
---------	-----------	--------------------

25-45 Staging Speed [Hz]

Default value: 0 Hz	Parameter type: Range	2-setup: All setups
Conversion index: -1	Data type: u_int16	Change during operation: True

The actual staging speed based on the staging threshold.

Table 451: Range:

Min: 0 Hz	Max: 400 Hz	Default value: 0 Hz
-----------	-------------	---------------------

25-47 Destaging Speed [Hz]

Default value: 0 Hz	Parameter type: Range	2-setup: All setups
Conversion index: -1	Data type: u_int16	Change during operation: True

The actual destaging speed based on the destaging threshold.

Table 452: Range:

Min: 0 Hz	Max: 400 Hz	Default value: 0 Hz
-----------	-------------	---------------------

4.19.4 25-5* Alternation Settings

Parameters for setting conditions for staging and destaging.

25-50 Lead Pump Alternation

Default value: [0] Off	Parameter type: Option	2-setup: All setups
Conversion index: -	Data type: u_int8	Change during operation: True

Change the lead pump so all pumps run equal time.

Table 453: Option:

[0]	Off
[1]	At staging
[2]	At command
[3]	At staging or command

25-51 Alternation Event

Default value: [0] External	Parameter type: Option	2-setup: All setups
Conversion index: -	Data type: u_int8	Change during operation: True

Choose the event that will change the lead pump.

Table 454: Option:

[0]	External
[1]	Alternation time interval
[2]	Sleep mode

25-52 Alternation Time Interval

Default value: 24 h	Parameter type: Range	2-setup: All setups
Conversion index: -	Data type: u_int16	Change during operation: True

Set the time period between automatic alternation of the lead pump.

Table 455: Range:

Min: 1 h	Max: 999 h	Default value: 24 h
----------	------------	---------------------

25-53 Alternation Timer Value

Default value: 0	Parameter type: Range	2-setup: All setups
Conversion index: 0	Data type: VisibleString	Change during operation: True

View the actual value of the alternation time interval timer.

Table 456: Range:

Min: 0	Max: 7	Default value: 0
--------	--------	------------------

25-55 Alternate if Load <= 50%

Default value: [1] Enabled	Parameter type: Option	2-setup: All setups
Conversion index: -	Data type: u_int8	Change during operation: True

Choose enable to change the variable-speed pump only if the pump load is less than 50%.

Table 457: Option:

[0]	Disabled
[1]	Enabled

25-56 Staging Mode at Alternation

Default value: [0] Slow	Parameter type: Option	2-setup: All setups
Conversion index: -	Data type: u_int8	Change during operation: True

Determine the time of the variable speed pump deceleration.

Table 458: Option:

[0]	Slow
[1]	Quick

25-57 Relays per Pump

Default value: 1	Parameter type: Range	2-setup: 1 setup
Conversion index: 0	Data type: u_int8	Change during operation: False

The number of relays used per pump.

Table 459: Range:

Min: 1	Max: 2	Default value: 1
--------	--------	------------------

25-58 Run Next Pump Delay

Default value: 0.1 s	Parameter type: Range	2-setup: All setups
Conversion index: -1	Data type: u_int16	Change during operation: True

Time between stopping the old variable-speed pump and starting the new appointed pump.

Table 460: Range:

Min: 0.1 s	Max: 5 s	Default value: 0.1 s
------------	----------	----------------------

25-59 Run on Mains Delay

Default value: 0.5 s	Parameter type: Range	2-setup: All setups
Conversion index: -1	Data type: u_int16	Change during operation: True

Time delay before a fixed-speed pump is staged on according to normal staging sequence.

Table 461: Range:

Min: 0.1 s	Max: 5 s	Default value: 0.5 s
------------	----------	----------------------

4.19.5 25-8* Status

Parameters for status of cascade operation, pumps, and relays.

25-80 Cascade Status

Default value: 0	Parameter type: Range	2-setup: All setups
Conversion index: 0	Data type: VisibleString	Change during operation: True

View the control status for the cascade controller.

Table 462: Range:

Min: 0	Max: 25	Default value: 0
--------	---------	------------------

25-81 Pump Status

Default value: 0	Parameter type: Range	2-setup: All setups
Conversion index: 0	Data type: VisibleString	Change during operation: True

View the status for the pumps connected.

- X=Disabled
- O=Off
- D=Speed controlled
- R=Mains

Table 463: Range:

Min: 0	Max: 25	Default value: 0
--------	---------	------------------

25-82 Lead Pump

Default value: 0	Parameter type: Range	2-setup: All setups
Conversion index: 0	Data type: u_int8	Change during operation: True

View which pump is speed-controlled by the drive.

Table 464: Range:

Min: 0	Max: 5	Default value: 0
--------	--------	------------------

25-84 Pump ON Time

Default value: 0 h	Parameter type: Range	2-setup: 1 setup
Conversion index: 0	Data type: u_int32	Change during operation: True

View the total operating hours of the connected pumps. This parameter can be reset to 0.

Table 465: Range:

Min: 0 h	Max: 2147483647 h	Default value: 0 h
----------	-------------------	--------------------

4.19.6 25-9* Service

Parameters for service use.

25-90 Pump Interlock

Default value: [0] Off	Parameter type: Option	2-setup: All setups
Conversion index: -	Data type: u_int8	Change during operation: True

Choose the pump to interlock for, for example, service. The pump will be taken out of any pump cycling, and more.

Table 466: Option:

[0]	Off
[1]	On

4.20 Parameter Group 30-** Special Features

4.20.1 30-2* Adv. Start Adjust

Parameter group for advanced start adjustments.

30-22 Locked Rotor Protection

Default value: [0] Off	Parameter type: Option	2-setup: All setups
Conversion index: -	Data type: u_int8	Change during operation: True

Set the locked rotor detection for PM motors.

Table 467: Option:

[0]	Off
[1]	On

30-23 Locked Rotor Detection Time [s]

Default value: 0.10 s	Parameter type: Range	2-setup: All setups
Conversion index: -2	Data type: u_int8	Change during operation: True

Set the locked rotor detection time in seconds for PM motors.

Table 468: Range:

Min: 0.05	Max: 1.00	Default value: 0.10
-----------	-----------	---------------------

5 Troubleshooting

5.1 Warning and Alarm Messages

The LEDs on the front of the drive and a code in the display signal a warning or an alarm.

A warning indicates a condition that may require attention or a trend that may eventually require attention. A warning remains active until the cause is no longer present. Under some circumstances, motor operation may continue.

If an alarm occurs, the drive has tripped. The trip removes power to the motor. It can be reset after the condition has been cleared by pressing [Reset], or through a digital input (*parameter group 5-1* Digital Inputs*). The event that caused an alarm cannot damage the drive or cause a dangerous condition. Alarms must be reset to restart operation once their cause has been rectified.

The reset can be done in 4 ways:

- By pressing [Reset].
- Via a digital input with the Reset function.
- Via serial communication.
- By resetting automatically using the Auto Reset function, see *parameter 14-20 Reset Mode*.

N O T I C E

After a manual reset pressing [Reset], press [Auto On] or [Hand On] to restart the motor.

If an alarm cannot be reset, the reason may be that its cause has not been rectified, or the alarm is trip-locked.

Alarms that are trip-locked offer extra protection, and the mains supply must be switched off before the alarm can be reset. After being switched back on, the drive is no longer blocked and may be reset as described above once the cause has been rectified.

Alarms that are not trip-locked can also be reset using the automatic reset function in *parameter 14-20 Reset Mode*. If a warning and alarm is marked against a code in [Table 469](#), this means that either a warning occurs before an alarm, or it can be specified whether it is a warning or an alarm that is to be shown for a given fault. This is possible, for instance, in *parameter 1-90 Motor Thermal Protection*. After an alarm or trip, the motor carries on coasting, and the alarm and warning flash on the drive. Once the problem has been rectified, only the alarm continues flashing until the drive is reset.

Whether a warning precedes an alarm and whether the drive suspends operations (trips) are defined in [Table 469](#). An X marked in [Table 469](#) means that action occurs. A warning precedes an alarm.

Table 469: Alarm/Warning Code List

No.	Description	Warning	Alarm	Trip Lock	Parameter Reference
2	Live zero error	(X)	(X)	–	<i>Parameter 6-01 Live Zero Timeout Function</i>
3	No motor	(X)	–	–	<i>Parameter 1-80 Function at Stop</i>
4	Mains phase loss	(X)	(X)	(X)	<i>Parameter 14-12 Function at Mains Imbalance</i>
7	DC over voltage	X	X	–	–
8	DC under voltage	X	X	–	–
9	Inverter overloaded	X	X	–	–
10	Motor ETR overtemperature	(X)	(X)	–	<i>Parameter 1-90 Motor Thermal Protection</i>
11	Motor thermistor overtemperature	(X)	(X)	–	<i>Parameter 1-90 Motor Thermal Protection</i>
13	Overcurrent	X	X	X	–
14	Ground fault	X	X	X	–
16	Short circuit	–	X	X	–
17	Control word time-out	(X)	(X)	–	<i>Parameter 8-04 Control Timeout Function</i>
24	Fan fault (Only on 400 V 30–90kW/40–125 hp)	X	X	–	<i>Parameter 14-53 Fan Monitor</i>

No.	Description	Warning	Alarm	Trip Lock	Parameter Reference
30	Motor phase U missing	–	(X)	(X)	<i>Parameter 4-58 Missing Motor Phase Function</i>
31	Motor phase V missing	–	(X)	(X)	<i>Parameter 4-58 Missing Motor Phase Function</i>
32	Motor phase W missing	–	(X)	(X)	<i>Parameter 4-58 Missing Motor Phase Function</i>
38	Internal fault	–	X	X	–
44	Ground fault 2	–	X	X	–
46	Gate drive voltage fault	–	X	X	–
47	24 V supply low	–	X	X	–
51	AMA check U_{nom} and I_{nom}	–	X	–	–
52	AMA low I_{nom}	–	X	–	–
53	AMA motor too large	–	X	–	–
54	AMA motor too small	–	X	–	–
55	AMA parameter out of range	–	X	–	–
56	AMA interrupted	–	X	–	–
57	AMA time-out	–	X	–	–
58	AMA internal fault	X	X	–	–
59	Current limit	X	–	–	–
60	External interlock	–	X	–	–
66	Heat sink temperature low	X	–	–	–
69	Power card temperature	X	X	X	–
70	Illegal FC Configuration	–	X	X	–
79	Illegal PS config	X	X	–	–
80	Drive initialised to default value	–	X	–	–
92	No-Flow	(X)	(X)	–	<i>Parameter 22-23 No-Flow Function</i>
93	Dry pump	X	X	–	<i>Parameter 22-26 Dry Pump Function</i>
94	End of curve	X	X	–	<i>Parameter 22-50 End of Curve Function</i>
95	Broken belt	X	X	–	<i>Parameter group 22-6* Broken Belt Detection</i>
99	Locked rotor	–	X	X	–
101	Flow/pressure Info Missing	–	–	–	–
126	Motor rotating	–	X	–	–
127	Back EMF too high	X	–	–	–

No.	Description	Warning	Alarm	Trip Lock	Parameter Reference
159	Check valve failure	X	–	–	<i>Parameter 22-04 Check Valve Monitor</i>
200	Fire mode	X	–	–	–
202	Fire mode limits exceeded	X	–	–	–
250	New spare parts	–	X	X	–
251	New type code	–	X	X	–

(X) Dependent on parameter.

A trip is the action when an alarm has appeared. The trip coasts the motor and can be reset by pressing [Reset] or via a digital input (*parameter group 5-1* Digital Inputs [1]*). The original event that caused an alarm cannot damage the drive or cause dangerous conditions. A trip lock is an action when an alarm occurs, which may cause damage to the drive or connected parts. A trip lock situation can only be reset by a power cycle.

Table 470: LED Indication

Warning	yellow
Alarm	flashing red

The alarm words, warning words, and extended status words can be read out via fieldbus or optional fieldbus for diagnosis. See also *parameter 16-90 Alarm Word*, *parameter 16-92 Warning Word*, and *parameter 16-94 Ext. Status Word*.

5.2 Alarm Words

Table 471: Alarm Words

Bit	Hex	Dec	<i>Parameter 16-90 Alarm Word</i>	<i>Parameter 16-91 Alarm Word 2</i>
0	1	1	0	0
1	2	2	Pwr.card temp	0
2	4	4	Earth fault	Servicetrip, typecode
3	8	8	0	Sparepart
4	10	16	Ctrl. word TO	0
5	20	32	Over current	No flow
6	40	64	0	0
7	80	128	Motor th. over	0
8	100	256	Motor ETR over	Broken belt
9	200	512	Inverter overld.	0
10	400	1024	DC under volt	0
11	800	2048	DC over volt.	0
12	1000	4096	Short circuit	External interlock
13	2000	8192	0	0
14	4000	16384	Mains ph. loss	0
15	8000	32768	AMA not OK	0

Bit	Hex	Dec	Parameter 16-90 Alarm Word	Parameter 16-91 Alarm Word 2
16	10000	65536	Live zero error	0
17	20000	131072	Internal fault	0
18	40000	262144	0	Fans error
19	80000	524288	U phase loss	0
20	100000	1048576	V phase loss	0
21	200000	2097152	W phase loss	0
22	400000	4194304	0	0
23	800000	8388608	Control voltage fault	0
24	1000000	16777216	0	0
25	2000000	33554432	VDD1 supply low	0
26	4000000	67108864	0	0
27	8000000	134217728	0	0
28	10000000	268435456	Earth fault	0
29	20000000	536870912	Drive initialized	0
30	40000000	1073741824	0	0
31	80000000	2147483648	0	0

5.3 Warning Words

Table 472: Warning Words

Bit	Hex	Dec	Parameter 16-92 Warning Word	Parameter 16-93 Warning Word 2
0	1	1	0	0
1	2	2	Pwr.card temp	0
2	4	4	Earth fault	0
3	8	8	0	0
4	10	16	Ctrl. word TO	0
5	20	32	Over current	No flow
6	40	64	0	0
7	80	128	Motor th. over	0
8	100	256	Motor ETR over	Broken belt
9	200	512	Inverter overld.	0
10	400	1024	DC under volt	0
11	800	2048	DC over volt.	0
12	1000	4096	0	0

Bit	Hex	Dec	Parameter 16-92 Warning Word	Parameter 16-93 Warning Word 2
13	2000	8192	0	0
14	4000	16384	Mains ph. loss	0
15	8000	32768	No motor	Auto DC braking
16	10000	65536	Live zero error	0
17	20000	131072	0	0
18	40000	262144	0	Fans warning
19	80000	524288	0	0
20	100000	1048576	0	0
21	200000	2097152	0	0
22	400000	4194304	0	Memory module
23	800000	8388608	24 V supply low	0
24	1000000	16777216	0	0
25	2000000	33554432	Current limit	0
26	4000000	67108864	Low temp.	0
27	8000000	134217728	0	0
28	10000000	268435456	0	0
29	20000000	536870912	0	Back-EMF too high
30	40000000	1073741824	0	0
31	80000000	2147483648	0	0

Note that 0 in the table indicates that this status word is not supported.

5.4 Extended Status Words

Table 473: Extended Status Words

Bit	Hex	Dec	Parameter 16-94 Ext. Status Word	Parameter 16-95 Ext. Status Word 2
0	1	1	Ramping	Off
1	2	2	AMA running	Hand/Auto
2	4	4	Start CW/CCW	0
3	8	8	0	0
4	10	16	0	0
5	20	32	Feedback high	0
6	40	64	Feedback low	0
7	80	128	Output current high	Control ready
8	100	256	Output current low	Drive ready

Bit	Hex	Dec	Parameter 16-94 Ext. Status Word	Parameter 16-95 Ext. Status Word 2
9	200	512	Output frequency high	Quick stop
10	400	1024	Output frequency low	DC brake
11	800	2048	0	Stop
12	1000	4096	0	0
13	2000	8192	Braking	Freeze output request
14	4000	16384	0	Freeze output
15	8000	32768	OVC active	Jog request
16	10000	65536	AC brake	Jog
17	20000	131072	0	Start request
18	40000	262144	0	Start
19	80000	524288	Reference high	0
20	100000	1048576	Reference low	Start delay
21	200000	2097152	0	Sleep
22	400000	4194304	0	Sleep boost
23	800000	8388608	0	Running
24	1000000	16777216	0	Bypass
25	2000000	33554432	0	Fire mode
26	4000000	67108864	0	External interlock
27	8000000	134217728	0	Fire mode limit exceed
28	10000000	268435456	0	Flystart active
29	20000000	536870912	0	0
30	40000000	1073741824	0	0
31	80000000	2147483648	Database busy	0

5.5 Descriptions of Warnings and Alarms

5.5.1 WARNING/ALARM 2, Live Zero Error

Cause

This warning or alarm only appears if programmed in *parameter 6-01 Live Zero Timeout Function*. The signal on 1 of the analog inputs is less than 50% of the minimum value programmed for that input. Broken wiring or a faulty device sending the signal can cause this condition.

Troubleshooting

- Check connections on all the analog input terminals. Control card terminals 53 and 54 for signals, terminal 55 common.
- Check that the drive programming matches the analog signal type.

5.5.2 WARNING/ALARM 3, No Motor

Cause

No motor is connected to the output of the drive.

Troubleshooting

- Check the cable connection between the drive and the motor.

5.5.3 WARNING/ALARM 4, Mains Phase Loss

Cause

A phase is missing on the supply side, or the mains voltage imbalance is too high. This message also appears for a fault in the input rectifier. Options are programmed in *parameter 14-12 Function at Mains Imbalance*.

Troubleshooting

- Check the supply voltage and supply currents to the drive.

5.5.4 WARNING/ALARM 7, DC Overvoltage

Cause

If the DC-link voltage exceeds the limit, the drive trips after a time.

Troubleshooting

- Extend the ramp time.
- Activate functions in *parameter 2-10 Brake Function*.
- Activate overvoltage control in *parameter 2-17 Over-voltage Control*.

5.5.5 WARNING/ALARM 8, DC Under Voltage

Cause

If the DC-link voltage (DC) drops below the undervoltage limit, the drive trips after a fixed time delay. The time delay varies with unit size.

Troubleshooting

- Check that the supply voltage matches the drive voltage.
- Perform the input voltage test.

5.5.6 WARNING/ALARM 9, Inverter Overload

Cause

The drive is about to cut out because of an overload (too high current for too long). The counter for electronic, thermal inverter protection issues a warning at 90% and trips at 100%, while giving an alarm. The drive cannot be reset until the counter is below 90%.

The fault occurs when the drive has run with more than 100% overload for too long.

Troubleshooting

- Compare the output current shown on the LCP with the drive rated current.
- Compare the output current shown on the LCP with measured motor current.
- Show the thermal drive load on the LCP and monitor the value. When running above the drive continuous current rating, the counter increases. When running below the drive continuous current rating, the counter decreases.

5.5.7 WARNING/ALARM 10, Motor Overload Temperature

Cause

According to the electronic thermal protection (ETR), the motor is too hot. Select whether the drive issues a warning or an alarm when the counter reaches 100% in *parameter 1-90 Motor Thermal Protection*. The fault occurs when the motor runs with more than 100% overload for too long.

For 18–30 kW: This protection is always enabled as an alarm. If the protection is triggered more than 10 repeated times, auto reset transitions to require a manual operation to clear the alarm.

Troubleshooting

- Check if the motor is overheating.
- Check if the motor is mechanically overloaded.
- Check that the motor current set in *parameter 1-24 Motor Current* is correct.

- Ensure that the motor data in *parameters 1-20 to 1-25* is set correctly.
- Run AMA in *parameter 1-29 Automatic Motor Adaption (AMA)*.

5.5.8 WARNING/ALARM 11, Motor Thermistor Overtemp

Cause

Check whether the thermistor is disconnected. Select whether the drive issues a warning or an alarm in *parameter 1-90 Motor Thermal Protection*.

Troubleshooting

- Check for motor overheating.
- Check if the motor is mechanically overloaded.
- Ensure that the thermistor is connected correctly.
- If using a thermal switch or thermistor, ensure that the programming of *parameter 1-93 Thermistor Source* matches sensor wiring.

5.5.9 WARNING/ALARM 13, Overcurrent

Cause

The inverter peak current limit is exceeded. The warning lasts about 1.5 s, then the drive trips and issues an alarm.

Troubleshooting

- This fault may be caused by shock loading or fast acceleration with high inertia loads.
- Turn off the drive. Check if the motor shaft can be turned.
- Check that the motor size matches the drive.
- Check that the motor data is correct in *parameters 1-20 to 1-25*.

5.5.10 ALARM 14, Earth (Ground) Fault

Cause

There is a discharge from the output phases to ground, either in the cable between the drive and the motor or in the motor itself.

Troubleshooting

- Turn off the drive and remove the ground fault.
- Check for ground faults in the motor by measuring the resistance to ground of the motor cables and the motor with a megohmmeter.

5.5.11 ALARM 16, Short Circuit

Cause

There is short-circuiting in the motor or motor wiring.

Troubleshooting

⚠ WARNING ⚠

HAZARDOUS VOLTAGE

AC drives contain hazardous voltage when connected to the AC mains or connected on the DC terminals. Failure to perform installation, start-up, and maintenance by skilled personnel can result in death or serious injury.

- Only skilled personnel must perform installation, start-up, and maintenance.

- Disconnect power before proceeding.
- Remove the power to the drive and repair the short circuit.

5.5.12 WARNING/ALARM 17, Control Word Timeout

Cause

There is no communication to the drive. The warning is only active when *parameter 8-04 Control Word Timeout Function* is NOT set to [0] Off.

If *parameter 8-04 Control Word Timeout Function* is set to [5] *Stop and trip*, a warning appears, and the drive ramps down to a stop and shows an alarm.

Troubleshooting

- Check the connections on the serial communication cable.
- Increase *parameter 8-03 Control Word Timeout Time*.
- Check the operation of the communication equipment.
- Verify that proper EMC installation was performed.

5.5.13 WARNING/ALARM 24, Fan Fault

Cause

The fan warning function is an extra protection function that checks whether the fan is running/mounted. The fan warning can be disabled in *parameter 14-53 Fan Monitor ([0] Disabled)*.

Troubleshooting

- Check fan resistance.

5.5.14 ALARM 30, Motor Phase U Missing

Cause

Motor phase U between the drive and the motor is missing.

Troubleshooting

- Turn off the drive and check motor phase U.

5.5.15 ALARM 31, Motor Phase V Missing

Cause

Motor phase V between the drive and the motor is missing.

Troubleshooting

- Turn off the drive and check motor phase V.

5.5.16 ALARM 32, Motor Phase W Missing

Cause

Motor phase W between the drive and the motor is missing.

Troubleshooting

- Turn off the drive and check motor phase W.

5.5.17 ALARM 38, Internal Fault

Cause

An internal fault occurs.

Troubleshooting

Contact your Danfoss supplier.

5.5.18 ALARM 44, Earth Fault II

Cause

There is a discharge from the output phases to ground, either in the cable between the drive and the motor or in the motor itself.

Troubleshooting

- Turn off the drive and remove the ground fault.
- Measure the resistance to ground of the motor cables and the motor with a megohmmeter to check for a ground fault in the motor.

5.5.19 ALARM 46, Gate Drive Voltage Low

Cause

The supply on the power card is out of range. There are 3 supplies generated by the switch mode power supply (SMPS) on the power card: 24 V, 5 V, and ± 18 V.

Troubleshooting

- Check the power card.

5.5.20 ALARM 47, 24 V Supply Low

Cause

The 24 V DC is measured on the control card. It occurs when the detected voltage on terminal 12 is lower than 18 V.

Troubleshooting

- Check the control card and the load connected.

5.5.21 ALARM 51, AMA Check Unom and Inom

Cause

The settings for motor voltage, motor current, and motor power are wrong.

Troubleshooting

- Check settings in *parameters 1-20 to 1-25*.

5.5.22 ALARM 52, AMA Low Inom

Cause

The motor current is too low.

Troubleshooting

- Check the settings in *parameter 1-24 Motor Current*.

5.5.23 ALARM 53, AMA Motor Too Big

Cause

The motor is too big for the AMA to operate.

Troubleshooting

- Check the settings in *parameter group 1-2* Motor Data*.

5.5.24 ALARM 54, AMA Motor Too Small

Cause

The motor is too small for the AMA to operate.

Troubleshooting

- Check the settings in *parameter group 1-2* Motor Data*.

5.5.25 ALARM 55, AMA Parameter Out of Range

Cause

The AMA cannot run because the parameter values of the motor are out of the acceptable range.

Troubleshooting

- Check the settings in *parameter group 1-2* Motor Data*.

5.5.26 ALARM 56, AMA Interrupted by User

Cause

The AMA is manually interrupted.

Troubleshooting

- Re-run the AMA calibration.

5.5.27 ALARM 57, AMA Internal Fault

Cause

Internal fault.

Troubleshooting

Try to restart the AMA. Repeated restarts can overheat the motor.

5.5.28 ALARM 58, AMA Internal Fault

Cause

Internal fault.

Troubleshooting

Contact the Danfoss supplier.

5.5.29 WARNING 59, Current Limit

Cause

The current is higher than the value in *parameter 4-18 Current Limit*.

Troubleshooting

- Ensure that the motor data in *parameters 1-20 to 1-25* is set correctly.
- Increase the current limit if necessary. Ensure that the system can operate safely at a higher limit.

5.5.30 ALARM 60, External Interlock

Cause

External interlock has been activated.

Troubleshooting

- To resume normal operation, apply 24 V DC to the terminal programmed for external interlock and reset the drive (via serial communication, digital I/O, or by pressing [Reset]).

5.5.31 WARNING 66, Heat Sink Temperature Low

Cause

This warning is based on the temperature sensor in the IGBT module.

The heat sink temperature measured as 0 °C (32 °F) could indicate that the temperature sensor is defective, thus causing the fan speed to increase to the maximum. If the sensor wire between the IGBT and the gate drive card is disconnected, this warning is produced.

Troubleshooting

- Check the IGBT thermal sensor.

5.5.32 ALARM 69, Power Card Temperature

Cause

The temperature sensor on the power card is either too hot or too cold.

Troubleshooting

- Check that the ambient operating temperature is within the limits.
- Check for clogged filters.
- Check fan operation.
- Check the power card.

5.5.33 ALARM 70, Illegal FC Configuration

Cause

The control card and power card are incompatible.

Troubleshooting

- To check compatibility, contact the Danfoss supplier with the type code from the unit nameplate and the part numbers on the cards.

5.5.34 ALARM 79, Illegal Power Section Configuration

Cause

Internal fault.

Troubleshooting

Contact the local supplier.

5.5.35 ALARM 80, Drive Initialized to Default Value

Cause

Parameter settings are initialized to default settings after a manual reset.

Troubleshooting

To clear the alarm, reset the unit.

5.5.36 WARNING/ALARM 92, No Flow

Cause

A no-flow condition has been detected in the system. *Parameter 22-23 No-Flow Function* is set for alarm.

Troubleshooting

- Troubleshoot the system and reset the drive after the fault has been cleared.

5.5.37 WARNING/ALARM 93, Dry Pump

A no-flow condition in the system with the drive operating at high speed may indicate a dry pump. *Parameter 22-26 Dry Pump Function* is set for warning or alarm.

Troubleshooting

- Troubleshoot the system.
- Reset the drive when the fault is cleared.

5.5.38 WARNING/ALARM 94, End of Curve

Feedback is lower than the set point. This may indicate a leakage in the system. *Parameter 22-50 End of Curve Function* is set for warning or alarm.

Troubleshooting

- Troubleshoot the system.
- Reset the drive when the fault is cleared.

5.5.39 WARNING/ALARM 95, Broken Belt

Cause

Torque is below the torque level set for no load, indicating a broken belt. See *parameter group 22-6* Broken Belt Detection*.

Troubleshooting

- Troubleshoot the system.
- Reset the drive after the fault is cleared.

5.5.40 ALARM 99, Locked Rotor

Cause

The rotor is blocked.

For 18–30 kW: If the protection is triggered more than 10 repeated times, auto reset transitions to require a manual operation to clear the alarm.

Troubleshooting

- Ensure that the rotor can operate freely.
- Check the settings in *parameter group 1-1* Motor Selection*.
- Check the settings in *parameter group 1-2* Motor Data*.

5.5.41 ALARM 101, Flow/pressure Info Missing

Cause

Sensorless-pump table is missing or wrong.

Troubleshooting

- Download sensorless-pump table again.

5.5.42 ALARM 126, Motor Rotating

Cause

High back-EMF voltage.

Troubleshooting

- Stop the rotor of the PM motor.

5.5.43 WARNING 127, Back EMF Too High

Cause

This warning applies to PM motors only. When the back-EMF exceeds $90\% \times U_{invmax}$ (overvoltage threshold) and does not drop to normal level within 5 s, this warning is reported. The warning remains until the back EMF returns to a normal level.

Troubleshooting

- Check the settings in *parameter group 1-2* Motor Data*.

5.5.44 WARNING 159, Check Valve Failure

When the drive is not in operation, a broken check valve leads to the motor runs in reverse.

Troubleshooting

- Troubleshoot the system.
- Reset the drive when the fault is cleared.

5.5.45 WARNING 200, Fire Mode

Cause

Fire mode has been activated.

Troubleshooting

- The warning clears when fire mode is removed.
- See the fire mode data in the alarm log.

5.5.46 WARNING 202, Fire Mode Limits Exceeded

Cause

Fire mode has suppressed 1 or more warranty-voiding alarms.

Troubleshooting

- Cycle power to the unit to remove the warning.
- See the fire mode data in the alarm log.

5.5.47 ALARM 250, New Spare Part

Cause

The power or switch mode supply has been exchanged.

Troubleshooting

- Contact the local Danfoss supplier.

5.5.48 ALARM 251, New Type Code

Cause

The drive has a new type code.

Troubleshooting

- Contact the local Danfoss supplier.

5.6 LCP Errors Messages

LCP errors are not warnings or alarms. They do not affect the operation of the drive. An LCP error example on the LCP is shown in the following illustration.

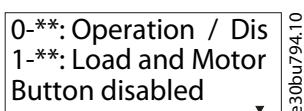

Illustration 20: LCP Error Example

Table 474: LCP Error List

LCP error code	Error message	Description
Err 84	LCP comm. lost	Communication between the LCP and the drive is lost.
Err 85	Key disabled	The LCP key is disabled. One of the LCP keys has been disabled in <i>parameter group 0-4* LCP Keypad</i> .
Err 86	LCP copy failed	Data copy failure. This error occurs when data is copied from drive to LCP, or from LCP to drive (<i>parameter 0-50 LCP Copy</i>).
Err 88	Data not compatible	LCP data incompatible. This error occurs when data is being copied from LCP to drive (<i>parameter 0-50 LCP Copy</i>). The typical reason is that data is moved between drive and LCP that have major software differences.
Err 89	Read only	Parameter read only. An operation is issued via LCP to write a value to a parameter that is read-only.
Err 90	Database busy	The parameter database of the drive is busy.
Err 91	Parameter invalid	The parameter value that is input via the LCP is invalid.
Err 92	Exceeds limits	The parameter value that is input via the LCP exceeds limits.
Err 93	Motor is running	The LCP copy operation cannot be performed when the drive is running.
Err 95	Not while running	The parameter cannot be changed while the drive is running.
Err 96	Password rejected	The password that is input via the LCP is incorrect.

6 Appendix

6.1 Abbreviations

°C	Degrees Celsius
°F	Degrees Fahrenheit
A	Ampere/AMP
AC	Alternating current
AWG	American wire gauge
AMA	Automatic motor adaptation
DC	Direct current
D-TYPE	Drive dependent
EMC	Electro-magnetic compatibility
ETR	Electronic thermal relay
$f_{M,N}$	Nominal motor frequency
g	Gram
Hz	Hertz
hp	Horsepower
I_{LIM}	Current limit
I_{INV}	Rated inverter output current
$I_{M,N}$	Nominal motor current
$I_{VLT,MAX}$	Maximum output current
$I_{VLT,N}$	Rated output current supplied by the drive
kg	Kilogram
kHz	Kilohertz
LCP	Local control panel
m	Meter
mH	Millihenry inductance
mA	Milliampere
ms	Millisecond
min	Minute
MCT	Motion control tool
nF	Nanofarad
Nm	Newton meter
n_s	Synchronous motor speed

$P_{M,N}$	Nominal motor power
PELV	Protective extra low voltage
PCB	Printed circuit board
PM motor	Permanent magnet motor
Regen	Regenerative terminals
RPM	Revolutions per minute
s	Second
T_{LIM}	Torque limit
$U_{M,N}$	Nominal motor voltage
V	Volts

6.2 Definitions

6.2.1 AC Drive

Coast

The motor shaft is in free mode. No torque on the motor.

$I_{VLT,MAX}$

Maximum output current.

$I_{VLT,N}$

Rated output current supplied by the drive.

$U_{VLT,MAX}$

Maximum output voltage.

6.2.2 Input

Control commands

Start and stop the connected motor with LCP and digital inputs.

Functions are divided into 2 groups.

Functions in group 1 have higher priority than functions in group 2.

Table 475: Function Groups

Group 1	Reset, coast stop, reset and coast stop, quick stop, DC brake, stop, and [Off].
Group 2	Start, pulse start, reversing, start reversing, jog, and freeze output.

6.2.3 Motor

Motor running

Torque generated on the output shaft and speed from 0 RPM to maximum speed on the motor.

f_{JOG}

Motor frequency when the jog function is activated (via digital terminals or bus).

f_M

Motor frequency.

f_{MAX}

Maximum motor frequency.

f_{MIN}

Minimum motor frequency.

$f_{M,N}$

Rated motor frequency (nameplate data).

I_M

Motor current (actual).

$I_{M,N}$

Nominal motor current (nameplate data).

$n_{M,N}$

Nominal motor speed (nameplate data).

n_s

Synchronous motor speed.

$$n_s = \frac{2 \times \text{Parameter 1-23} \times 60 \text{ s}}{\text{Parameter 1-39}}$$

n_{slip}

Motor slip.

$P_{M,N}$

Rated motor power (nameplate data in kW or hp).

$T_{M,N}$

Rated torque (motor).

U_M

Instantaneous motor voltage.

$U_{M,N}$

Rated motor voltage (nameplate data).

Break-away torque

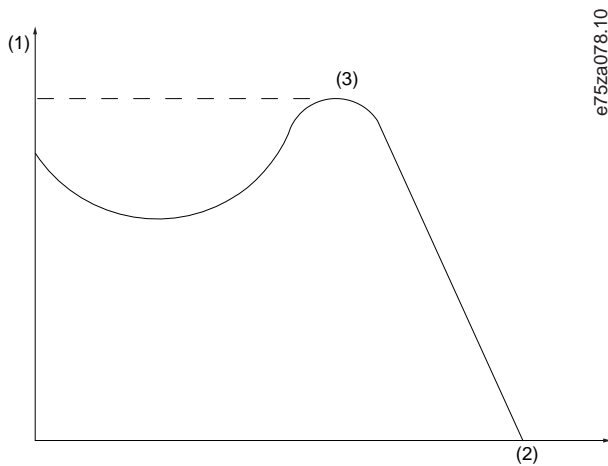

Illustration 21: Break-away Torque

1	Torque	3	Pull-out
2	RPM		

η_{VLT}

The efficiency of the drive is defined as the ratio between the power output and the power input.

Start-disable command

A start-disable command belonging to the control commands in group 1. See the table in chapter Input for more details.

Stop command

A stop command belonging to the control commands in group 1. See the table in chapter Input for more details.

6.2.4 References

Analog reference

A signal transmitted to the analog inputs 53 or 54 can be voltage or current.

- Current input: 0–20 mA and 4–20 mA
- Voltage input: 0–10 V DC

Bus reference

A signal transmitted to the serial communication port (FC port).

Binary reference

A signal transmitted via the serial communication port.

Preset reference

A defined preset reference to be set from -100% to +100% of the reference range. Selection of 8 preset references via the digital terminals. Selection of 4 preset references via the bus.

Ref_{MAX}

Determines the relationship between the reference input at 100% full scale value (typically 10 V, 20 mA) and the resulting reference. The maximum reference value is set in *parameter 3-03 Maximum Reference*.

Ref_{MIN}

Determines the relationship between the reference input at 0% value (typically 0 V, 0 mA, 4 mA) and the resulting reference. The minimum reference value is set in *parameter 3-02 Minimum Reference*.

6.2.5 Miscellaneous

Analog inputs

The analog inputs are used for controlling various functions of the drive.

There are 2 types of analog inputs:

- Current input: 0–20 mA and 4–20 mA.
- Voltage input: 0–10 V DC.

Analog outputs

The analog outputs can supply a signal of 0–20 mA, 4–20 mA, or a digital signal.

Automatic motor adaptation, AMA

The AMA algorithm determines the electrical parameters for the connected motor at standstill and compensates for the resistance based on the length of the motor cable.

Digital inputs

The digital inputs can be used for controlling various functions of the drive.

Digital outputs

The drive features 2 solid-state outputs that can supply a 24 V DC (maximum 40 mA) signal.

DSP

Digital signal processor.

Relay outputs

The drive provides 2 programmable relay outputs.

ETR

Electronic thermal relay is a thermal load calculation based on present load and time. Its purpose is to estimate the motor temperature and prevent overheating of the motor.

Initializing

If initializing is carried out (*parameter 14-22 Operation Mode*), the drive returns to the default setting.

Parameter 14-22 Operation Mode does not initialize communication parameters, fault log, or fire mode log.

Intermittent duty cycle

An intermittent duty rating refers to a sequence of duty cycles. Each cycle consists of an on-load and an off-load period. The operation can be either periodic duty or nonperiodic duty.

LCP

The local control panel makes up a complete interface for control and programming of the drive. The LCP is detachable. With the installation kit option, the LCP can be installed up to 3 m (9.8 ft) from the drive in a front panel.

NLCP

The numerical local control panel interface for control and programming of the drive. The display is numerical and the panel is used to show process values. The NLCP has storing and copy functions.

GLCP

The graphic local control panel interface for control and programming of the drive. The display is graphic and the panel is used to show process values. The GLCP has storing and copy functions.

lsb

Least significant bit.

msb

Most significant bit.

MCM

Short for mille circular mil, an American measuring unit for cable cross-section. 1 MCM = 0.5067 mm².

On-line/off-line parameters

Changes to on-line parameters are activated immediately after the data value is changed. To activate changes to offline parameters, press [OK].

PI controller

The PI controller maintains the desired speed, pressure, temperature, and so on, by adjusting the output frequency to match the varying load.

Process PID

The PID control maintains speed, pressure, and temperature by adjusting the output frequency to match the varying load.

PCD

Process control data.

PFC

Power factor correction.

Power cycle

Switch off the mains until the display (LCP) is dark, then turn power on again.

Power factor

The power factor is the relation between I_1 and I_{RMS} , where I_1 is the fundamental current, and I_{RMS} is the total RMS current including harmonic currents.

$$\text{Power factor} = \frac{\sqrt{3} \times U \times I_1 \cos\phi_1}{\sqrt{3} \times U \times I_{RMS}}$$

For VLT® Flow Drive FC 111 drives, $\cos\phi_1 = 1$, therefore:

$$\text{Power factor} = \frac{I_1 \times \cos\phi_1}{I_{RMS}} = \frac{I_1}{I_{RMS}}$$

The power factor indicates to which extent the drive imposes a load on the mains supply. The lower the power factor, the higher the I_{RMS} for the same kW performance.

$$I_{RMS} = \sqrt{I_1^2 + I_5^2 + I_7^2 + \dots + I_n^2}$$

In addition, a high power factor indicates that the different harmonic currents are low.

The built-in DC coils produce a high-power factor, minimizing the imposed load on the mains supply.

Pulse input/incremental encoder

An external, digital pulse transmitter used for feeding back information on motor speed. The encoder is used in applications where great accuracy in speed control is required.

RCD

Residual current device.

Set-up

Save parameter settings in 2 set-ups. Change between the 2 parameter set-ups and edit 1 set-up while another set-up is active.

SFAVM

Acronym describing the switching pattern stator flux-oriented asynchronous vector modulation.

Slip compensation

The drive compensates for the motor slip by giving the frequency a supplement that follows the measured motor load, keeping the motor speed almost constant.

Smart logic control (SLC)

The SLC is a sequence of user-defined actions executed when the smart logic controller evaluates the associated user-defined events as true.

STW

Status word.

THD

Total harmonic distortion states the total contribution of harmonic distortion.

Thermistor

A temperature-dependent resistor placed where the temperature is monitored (drive or motor).

Trip

Trip is a state entered in fault situations. Examples of fault situations:

- The drive is subject to an over voltage.
- The drive protects the motor, process, or mechanism.

Restart is prevented until the cause of the fault has disappeared, and the trip state is canceled by activating reset or, in some cases, by being programmed to reset automatically. Do not use trip for personal safety.

Trip lock

Trip lock is a state entered in fault situations when the drive is protecting itself and requiring physical intervention. For example, a short circuit on the output triggers a trip lock. A locked trip can only be canceled by cutting off mains, removing the cause of the fault, and reconnecting the drive. Restart is prevented until the trip state is canceled by activating reset or, sometimes, by being programmed to reset automatically. Do not use trip lock for personal safety.

VT characteristics

Variable torque characteristics used for pumps and fans.

VVC⁺

If compared with standard voltage/frequency ratio control, voltage vector control (VVC⁺) improves the dynamics and stability, both when the speed reference is changed and in relation to the load torque.

60° AVM

Refer to the switching pattern 60° asynchronous vector modulation.

Index

A	
Abbreviations.....	205
Active setup.....	34
Additional resource.....	5
AMA.....	48, 208
Analog input.....	207, 208
Analog output.....	208
Application selection.....	35
Automatic motor adaption.....	48
B	
Break-away torque.....	207
Broken belt detection.....	173
C	
Changes made.....	10
Check valve failure.....	203
Coast.....	206
Configuration mode.....	40
Constant pressure water supply.....	35
Custom readout.....	36
D	
d-axis inductance.....	49
DC brake.....	57
Display.....	9
Display text.....	38, 38, 38
Document version.....	5
E	
Electronic thermal relay.....	208
End of curve.....	173, 202
ETR.....	208
F	
Fire mode.....	178
Flying start.....	55
Freeze output.....	206
G	
GLCP.....	208
I	
Indexed parameters.....	27
Indicator light.....	9, 10
Installation	
Qualified personnel.....	7
Intermittent duty cycle.....	208
IT grid.....	33
J	
Jog.....	206
L	
Language.....	32
LCP.....	9, 26, 206, 208
Leakage current.....	8
Local control panel.....	9
M	
Main menu.....	26
Main reactance.....	49
Mains	
Warning.....	197
MCT 10 setup software.....	5, 9
Menu key.....	9
Motor	
Control principle.....	40
Power.....	46
Voltage.....	47
Frequency.....	47
Current.....	47
Nominal speed.....	47
Poles.....	50
Multi pump control application.....	35
N	
Navigation key.....	9
NLCP.....	208
No-flow detection.....	166
Nominal motor current.....	207
Nominal motor speed.....	207
O	
Open loop control.....	35
Operation key.....	10
Over-voltage control.....	59
Over-voltage gain.....	59
P	
Power cycle.....	209
Process closed loop control.....	35
Programming.....	9
Purpose of the manual.....	5
Q	
q-axis inductance.....	50
Qualified personnel.....	7
Quick menu.....	10
Quick transfer.....	26
R	
RCD.....	209
Recommended initialization.....	27, 27
Regional settings.....	32
Rotor resistance.....	49
S	
Serial communication.....	208
Short circuit	
Alarm.....	198
Sleep mode.....	170
Slip compensation.....	209
Smart logic control.....	115
Smart logic controller.....	126

Software version.....	5	U	
Start delay.....	54	U/f characteristic.....	52, 52
Start mode.....	54	V	
Stator leakage reactance.....	49	Voltage	
Stator resistance.....	49	Safety warning.....	7, 198
Status menu.....	10	W	
Symbols.....	7	Warning words.....	194
Synchronous motor speed.....	207	Wiring schematic.....	5
T		Wizard	
Torque characteristic.....	41	Open-loop application.....	10
Trip.....	210	Closed-loop application.....	10
Trip lock.....	210	Motor set-up.....	10
Two-finger initialization.....	27, 27		

Danfoss A/S
Ulsnaes 1
DK-6300 Graasten
vlt-drives.danfoss.com

Danfoss can accept no responsibility for possible errors in catalogs, brochures, and other printed material. Danfoss reserves the right to alter its products without notice. This also applies to products already on order provided that such alterations can be made without subsequential changes being necessary in specifications already agreed. All trademarks in this material are property of the respective companies. Danfoss and the Danfoss logotype are trademarks of Danfoss A/S. All rights reserved.

